



Core Stability Dome

Workouts combine cardio, strength training, balance and flexibility



Specifically designed to integrate balance into every aspect of fitness training. This dynamic training device adds variety and challenge to any sports and fitness training program.



Health & Safety

Important - This unit is intended for home use only

- Read all the instructions in this manual before using the product. Keep this manual for the entire life of the product.
- Always perform general warm-up activities prior to performing any exercises.
- Perform exercises in a slow and controlled manner.
- Keep abdominal muscles tight while performing exercises.
- Avoid straining or holding breath while performing exercises.
- Discontinue any exercise that is uncomfortable or causes pain.
- Consult your physician before beginning any type of exercise program. This is especially important as you get older and for individuals with pre-existing health conditions.

Mazimum User Weight : 120 kgs

Care & Maintenance

- Wipe surfaces dry following each training session.
- Do not use any solvents, clean only with a damp cloth.



Warning: Before beginning any exercise program, consult your Doctor. This is especially important for persons over the age of 35 or persons with pre-existing health problems. You **MUST** read all instructions before using any fitness equipment. ARGOS and its associates assume no responsibility for personal injury or property damage sustained by or through the use of this product.

Warming Up / Stretching / Cooling Down

Warming Up

A warm-up is essential before any exercise is undertaken. The correct pre-exercise procedure will prevent injury and allow the body to better perform the required movements. A proper warm-up increases your body temperature, heart rate, and circulation in preparation for exercise. It is then important to release tension from the muscles to allow muscles greater range to move and perform. This is done by following mobility drills that can be found at www.mattroberts.co.uk.

The key areas to mobilise are:

- 1) Hip Flexors
- 2) Lower Back
- 3) Hamstrings
- 4) Upper Back
- 5) Quadriceps
- 6) Calves

Toe Touch Stretch / Hamstring Stretch



Suggested Stretches

The correct form for several basic stretches is shown at the right. Move slowly as you stretch, never bounce.

1. Toe touch stretch :

Stand with your knees bent slightly and slowly bend forward from your hips. Allow your back and shoulders to relax as you reach down toward your toes as far as possible. Hold for 15 counts, then relax. Repeat 3 times.



2. Hamstring Stretch :

Sit with one leg extended. Bring the sole of the opposite foot toward you and rest it against the inner thigh of your extended leg. Reach toward your toes as far as possible. Hold for 15 counts, then relax. Repeat 3 times for each leg. Stretches: Hamstrings, lower back and groin.

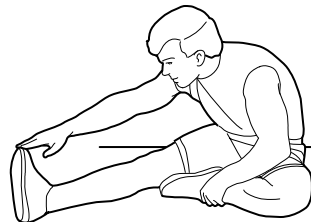

Stretching / Cooling Down



3. Calf/Achilles Stretch :

With one leg in front of the other, reach forward and place your hands against a wall. Keep your back leg straight and your back foot flat on the floor bend your front leg, lean forward and move your hips toward the wall. Hold for 15 counts, then relax. Repeat 3 times for each leg. To cause further stretching of the Achilles tendons, bend your back leg as well. Stretches: Calves, Achilles tendons and ankles.

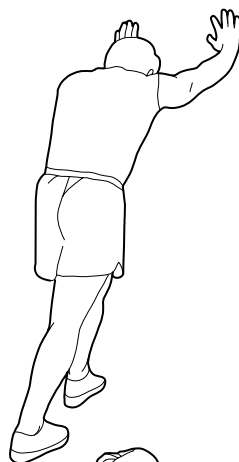

4. Quadriceps Stretch :

With one hand against a wall for balance, reach back and grasp one foot with your other hand. Bring your heel as close to your buttocks as possible. Hold for 15 counts, then relax. Repeat 3 times for each leg. Stretches: Quadriceps and hip muscles.



5. Inner Thigh Stretch :

Sit with the soles of your feet together and your knees outward. Pull your feet toward your groin area as far as possible. Hold for 15 counts, then relax. Repeat 3 times.



Note



TOPSIDE OF DOME

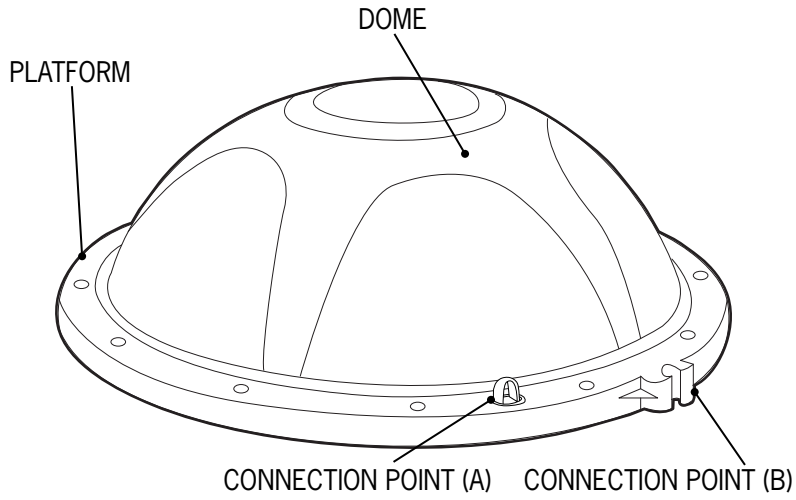

UNDERSIDE OF DOME

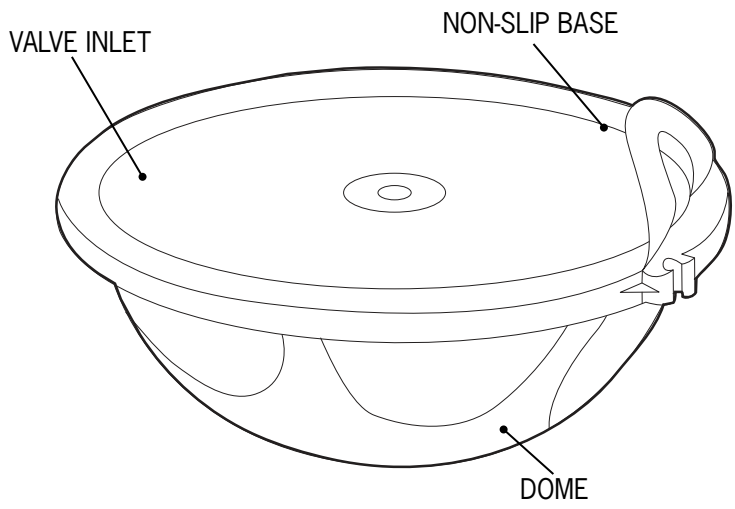

Single-leg Balance with Leg Raise



[Method]

Stand balanced on one leg whilst raising the other leg, hold for 30-60 seconds or for as long as you can.

Change to the other leg and repeat.

[Effect]

Enhances the body's balancing ability and reaction time.

Exercises front thigh muscles of the raised leg.



Single-leg Balance with Side Raise



[Method]

Stand balanced on one leg whilst raising the other leg out sideways, hold for 30-60 seconds or for as long as you can. Stay a while (no matter short or long time). Change to the other leg and repeat it again.

[Effect]

Enhances the body's balancing ability and reaction time.
Exercises the outer thigh and buttock muscles of the raised leg.



Burpee Jump



[Method]

Flip the dome back on its flat side and stand with feet shoulder-width apart. Place both hands on the dome and jump out into a push-up position.

(A) Jump back into a squat and stand up.

(B) Jump onto and off the dome with both feet. Repeat 12 to 15 times.

[Effect]

Enhances the core, shoulders, lower body.

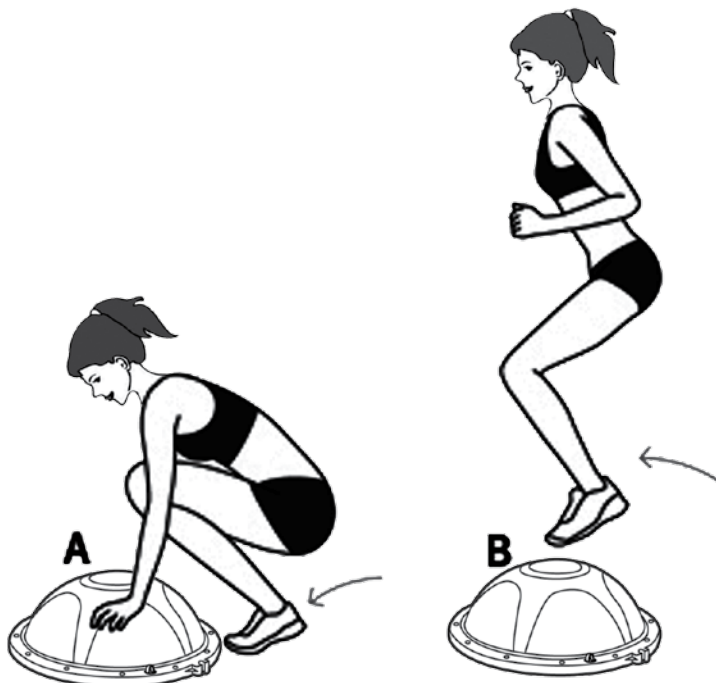

Abdomen-arm-leg Mixed Exercise



[Method]

Sit on the dome, bend one leg and extend the other leg horizontally above the floor.

Use one hand to hold the bent leg and extend the other hand backward.

[Effect]

Enhances the abdomen, arm and leg muscles.

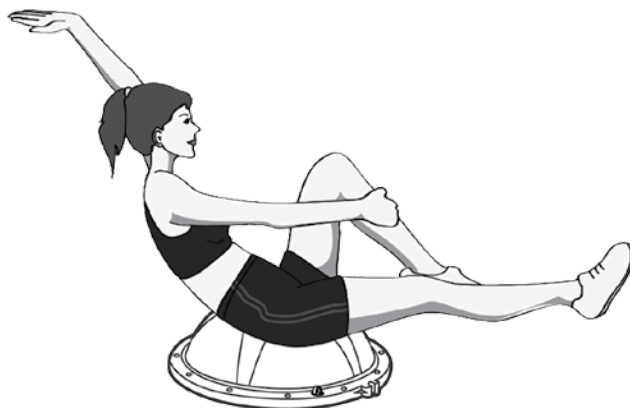

Sit-Up Exercise



[Method]

Sit on the dome, bend up legs and place both hands behind the head. Keep balance and try to do a stationary or continuous sit-up exercise.

[Effect]

Exercise the abdominal muscles.



Forearm Plank



[Method]

Place the dome flat-side down. Rest your forearms on top of the dome and come into a plank position, keeping your shoulders over your elbows. Your body should be in a straight line from head to heels. Pull your abdominals in toward your spine and squeeze your gluteals. Hold for one minute.

[Effect]

Enhances the core, shoulders and lower body.

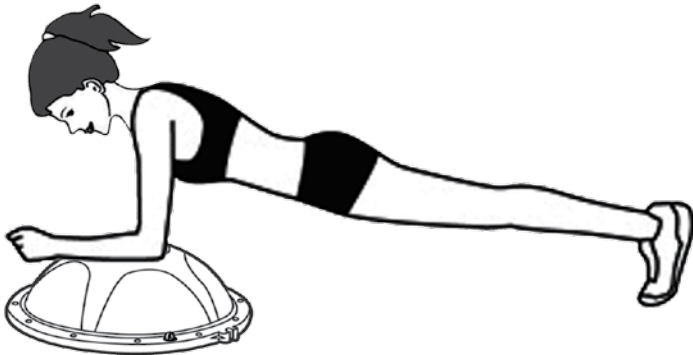

Side Plank



[Method]

Rest your right forearm on top of the dome, stack your left foot on top of your right, and lift your body off the ground.

Make sure you're in a straight line from head to feet.

Contract your abs and squeeze your glutes. Hold for 30 seconds, then switch sides.

[Effect]

Exercise the obliques, shoulders, lower body.

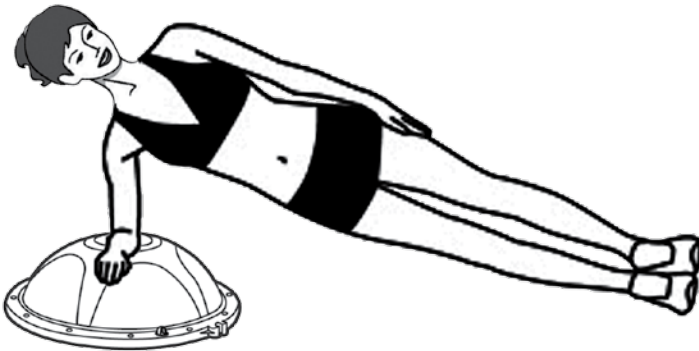

One-Legged Bridge



[Method]

Lie on your back with your right foot on the dome, left leg extended toward the ceiling, and arms along the floor, palms up.

Press your right foot into the dome and lift your torso until it's in line with your right thigh. Hold for two counts, then slowly lower to start.

Repeat 15 times, then switch sides.

[Effect]

Enhances the core, glutes, hamstrings.

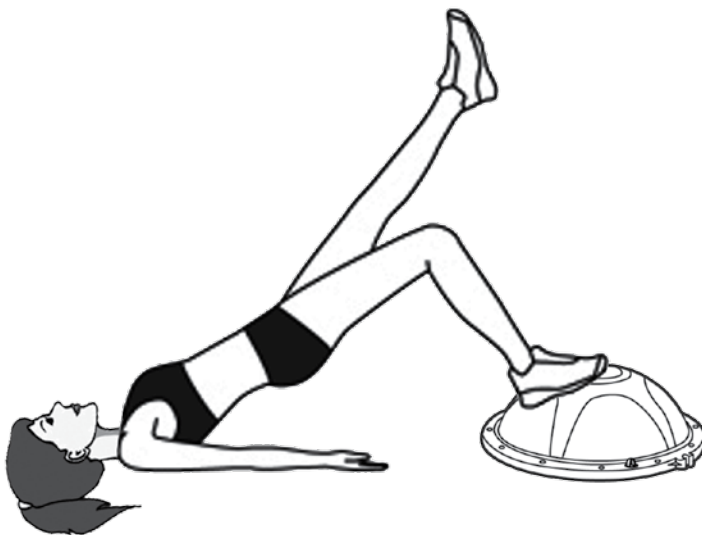

Mountain Climber



[Method]

Flip the dome over onto its dome surface.

Grip the sides of the platform and come into a plank position.

Run in place, quickly bringing each knee to your chest.

Continue for one minute.

[Effect]

Exercise the core, shoulders, lower body.



Push-up



[Method]

Flip the dome over onto its dome surface.

Grip the sides of the platform or place your hands on top of it and perform a push-up, holding your body in a straight line.

Do 10 repetitions.

[Effect]

Exercise the core, chest, arms, lower body.



PRODUCED FOR ARGOS STORES LTD
489-499 AVEBURY BOULEVARD
MK9 2NW
HELP LINE NUMBER: 0845 6000 464