

POLANIK
Poland, Życzliwa 11
97-300 Piotrków Trybunalski

tel. +48 44 646 44 81
tel. +48 44 648 50 89
fax +48 44 646 43 58

e-mail: info@polanik.com
www.polanik.com



TECHNICAL SPECIFICATION **ASSEMBLY MANUAL**

Hammer racks **HR-12** **HR-12-w**



File: 2014-07-15

PRODUCT SUPPORT
Paweł Ciechanowski
p.ciechanowski@polanik.com

Contents

Chapter	Page
I. General description and use	2
II. Technical specification	2
III. Packing and transport	2
IV. Assembly	3
V. Operation and maintenance	3
VI. Declaration	4

I. General description and use

Racks (HR series) are designed for storing hammers in warehouses and for using them during athletics competitions.

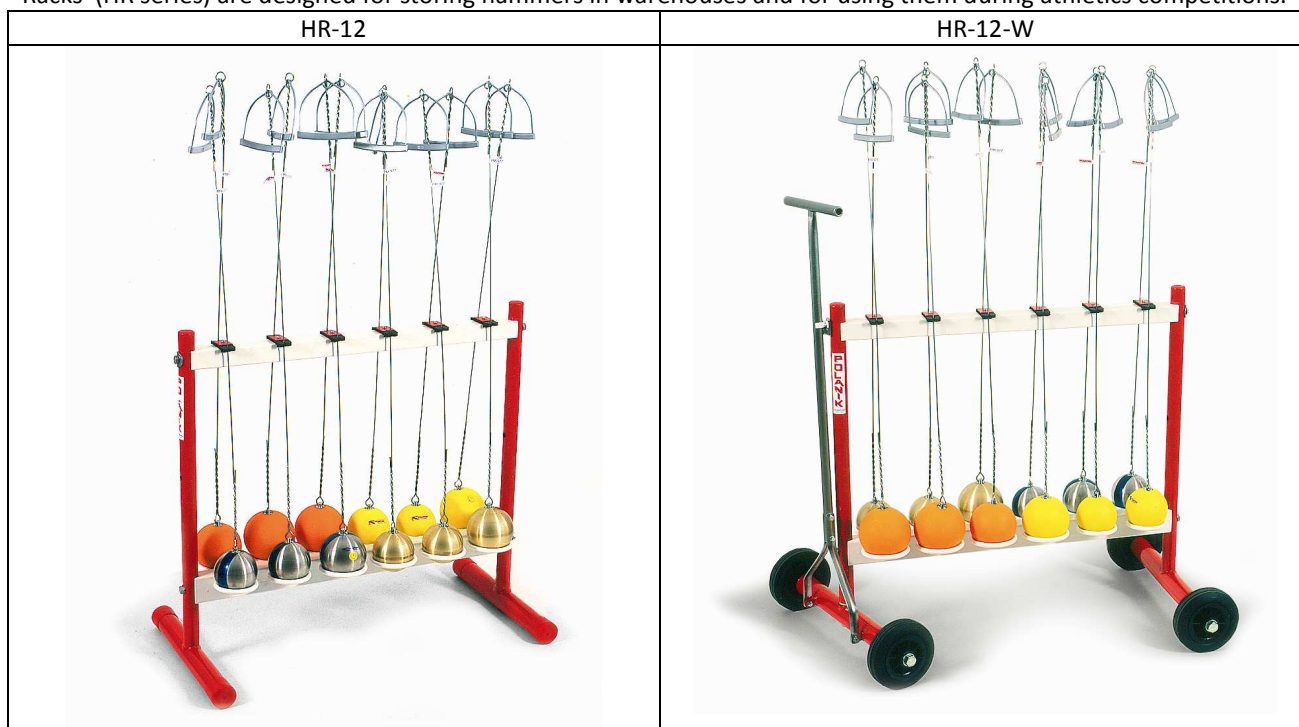

II. Technical specification

Code	Weight [kg]	Dimensions after assembly length/width/height [mm]	Material	Model	Capacity[pcs]
HR-12	8,30	820/420/760	steel powder painted	stationary	12
HR-12-W	10,00	820/420/760	steel powder painted	on wheels	12

III. Packing and transport

The rack is delivered in parts, packed in a cartoon box

IV. Assembly

The HR-12 rack should be screwed using M6x35 screws and pads Ø8. The rack HR-12-W should be screwed in the way the picture below shows.

<i>HR-12-W</i>		M16x100	M8x65	M6x35	M6x20	M6	Ø8	Ø16.5	Ø6.5
Poz./Item	szt./pcs	4	4	2	2	4	4	4	8
1	1								
2	1								
3	4								
4	4								
5	1								
6	1								
7	1								
8	2								
9	1								

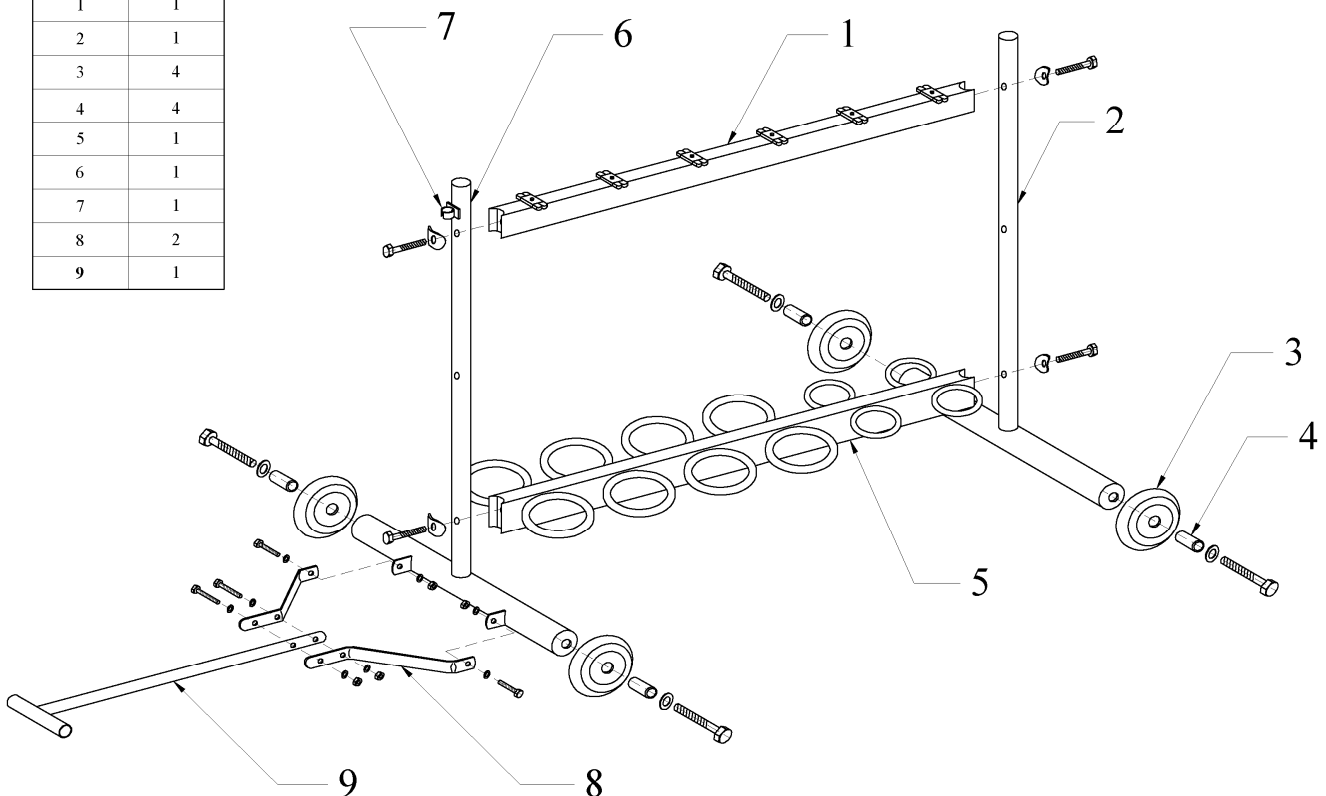

V. Operation and maintenance

The rack should be stored in a roofed and dry place.

Even the best technical solutions cannot substitute for common sense. The usage of the product must take place under the supervision of qualified trainers. The producer shall not be liable for any incidents caused by the improper product installation, assembly or its misuse. The producer reserves the right to introduce without warning changes in product constructions and colours.

POLANIK
Poland, Życzliwa 11
97-300 Piotrków Trybunalski

tel. +48 44 646 44 81
tel. +48 44 648 50 89
fax +48 44 646 43 58

e-mail: info@polanik.com
www.polanik.com



VI. Declaration

- 1) No. 2013-12-04
- 2) Issuer's name: POLANIK Sp. z o. o.
Issuer's address: Życzliwa 11, 97-300 Piotrków Tryb.
- 3) Declared items

No.	Name	Code
1	Stationary hammer rack	HR-12
2	Hammer rack on wheels	HR-12-W

- 4) Technical specification described above is in accordance with the factory's internal engineering standard.

Additional information

- 5) The declaration was made for:

Purchaser and User

The declaration was signed on behalf and with authorization:

POLANIK Sp. z o. o.

2014-07-15 Piotrków Tryb.

(Date and place)

Paweł Ciechanowski

Product manager

- 6)

(Name, function)

.....
(Signature or it's equivalent authorized by the Exhibitor)