

Art.Nr. 3097902

BEHENDIGHEIDSPARCOURS
PARCOURS D'AGILITÉ
AGILITY TRAIL
GESCHICKLICHKEITSWEG
CIRCUITO DE AGILIDAD
PERCORSO DI AGILITÀ

Montagehandleiding

Notice de montage

Assembling manual

Montageanleitung

Instrucciones para el montaje

Istruzioni di installazione

Leeftijd:
Age: 4-12
Age group:
Alter:
Edad:
Età:

EUROPLAY nv
Eegene 9
B-9200 DENDERMONDE
tel. 32.52.22 66 22
fax.32.52.22 67 22
www.europlay.eu

Dat.: 4/10/2013

Page: 1/5

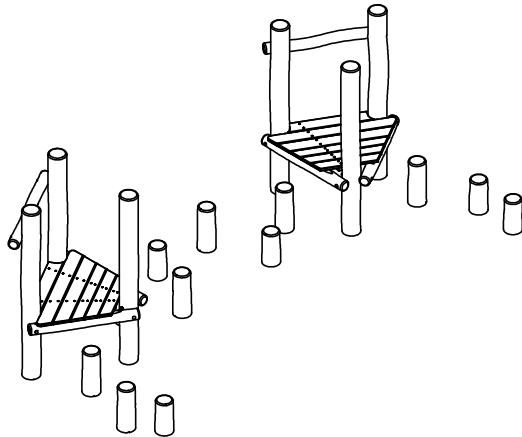

VALHOOGTE / HAUTEUR DE CHUTE /
FALL HEIGHT / FALLHÖHE/
ALTURA DE CAÍDA / ALTEZZA DI CADUTA

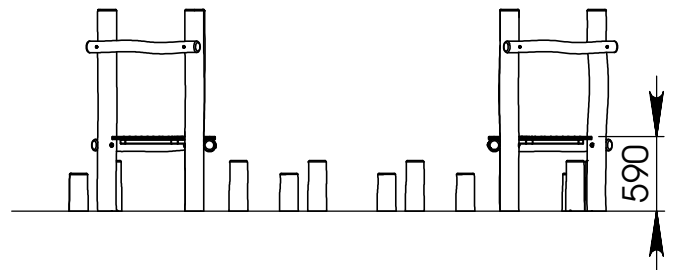

VEILIGHEIDSAFSTAND / ESPACE DE CHUTE / SAFETY AREA /
SICHERHEITSAFSTAND / ZONA DE SEGURIDAD / DISTANZA DI SICUREZZA

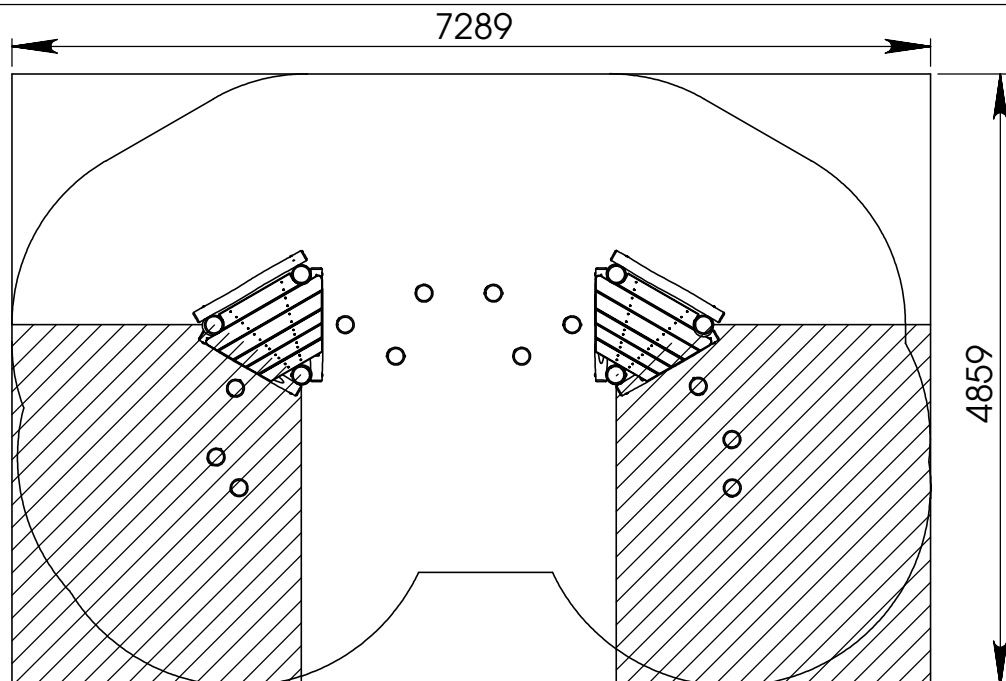

AFMETINGEN
DIMENSIONS
MASSE
DIMENSIONES
DIMENSIONI
L : 4,4m
H : 1,6m
Br: 2,0m

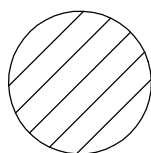

Samenvoegingszone avonturenpad
Zone de liaison parcours d'aventures
Verbindungsfeld survival parcours
Linking zone adventure path
Zona de conexión recorrido aventurero
Zona di allineamento percorso d'avventura

±35,5m2

Benodigdheden - Liste des pièces - Materials - Benötigtes - Accesorios - Requisiti

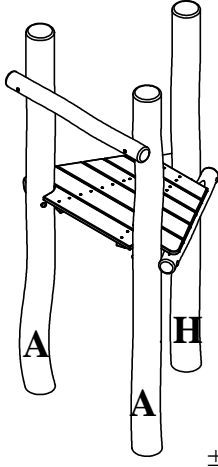
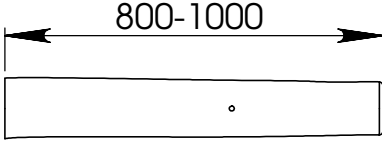
<p>2x</p>  <p>±125kg</p>	<p>12x</p>  <p>(Ø140-Ø160)</p> <p>±15kg</p>
---	---

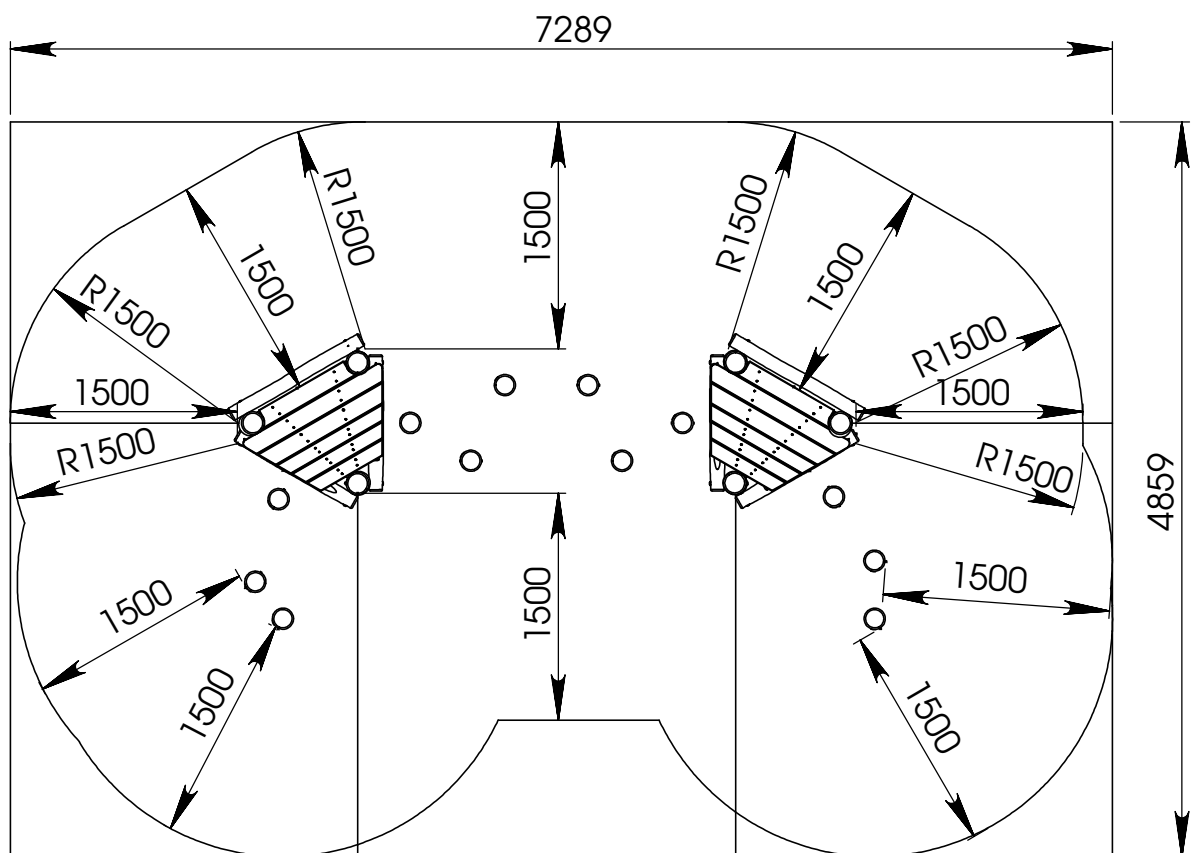

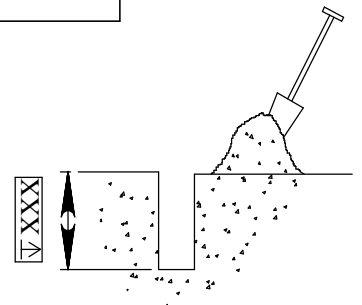
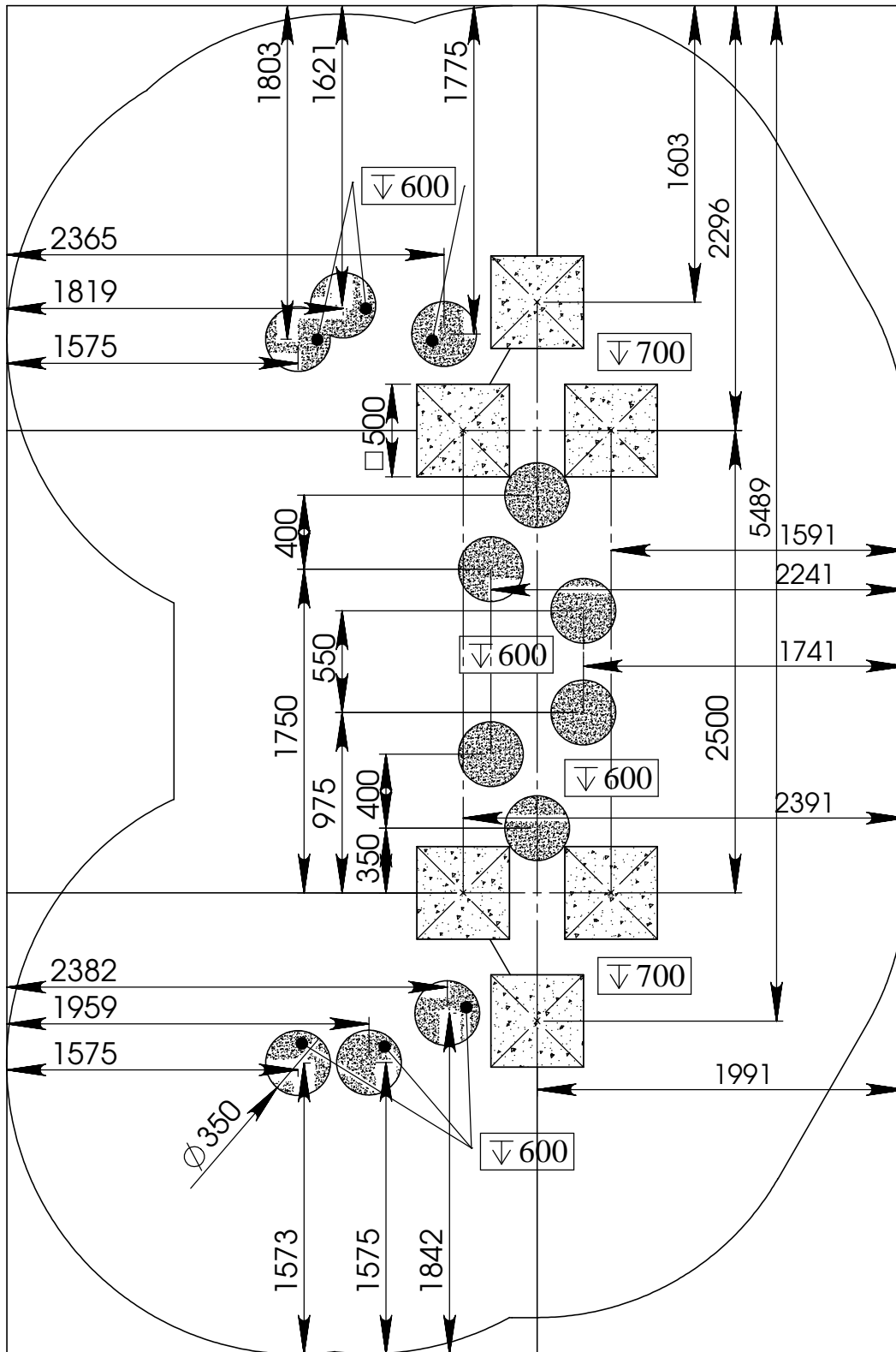

①

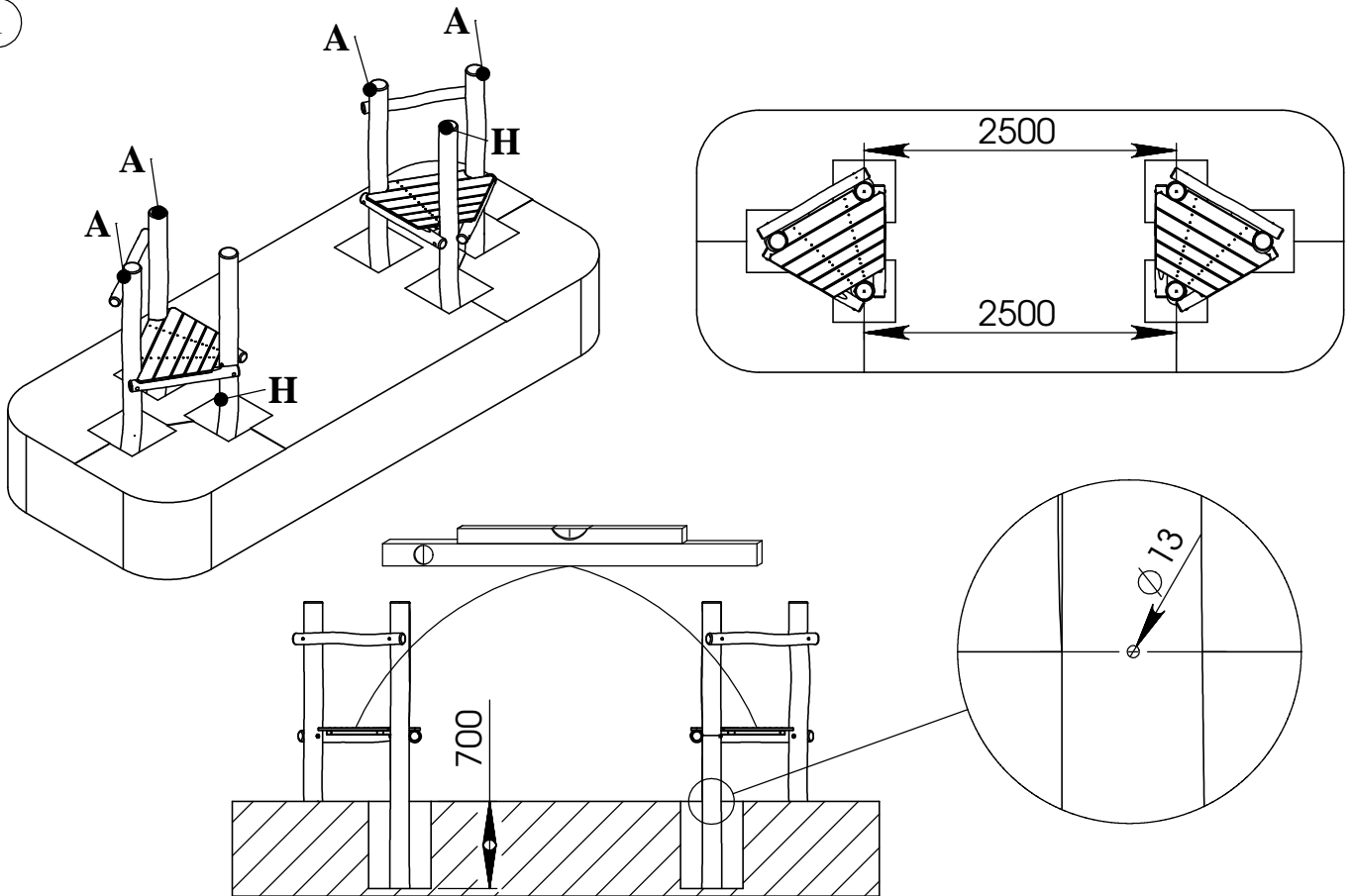

②

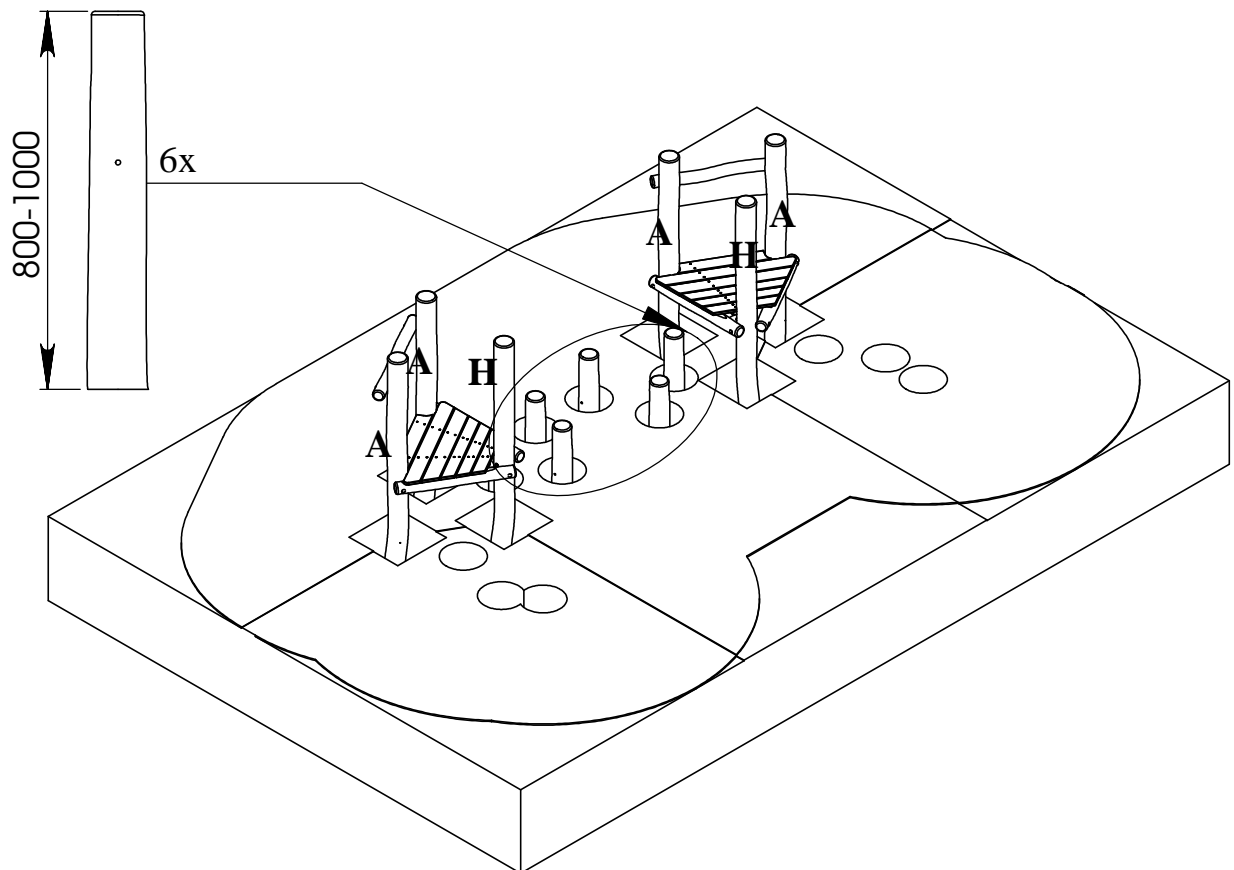

3

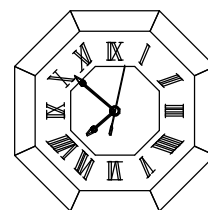
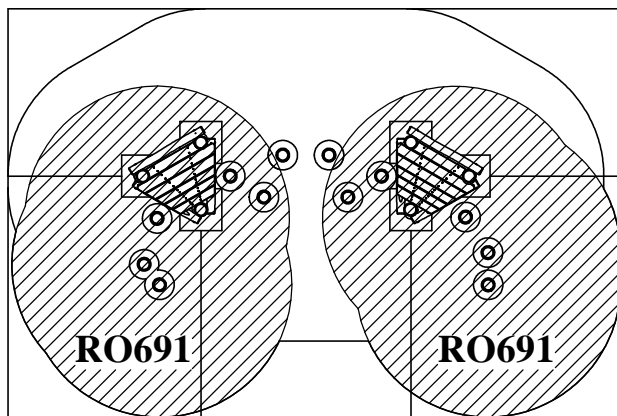
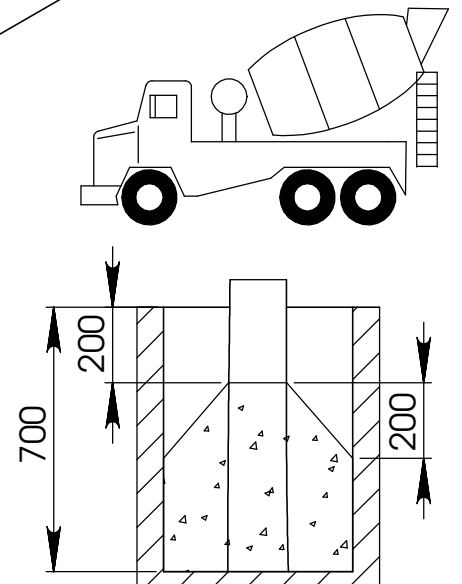
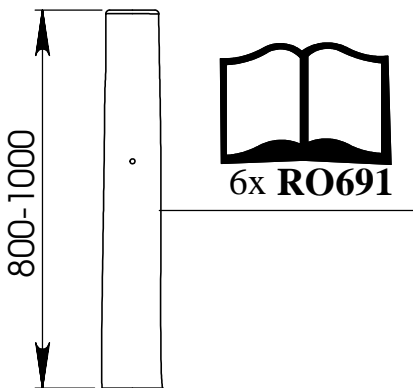
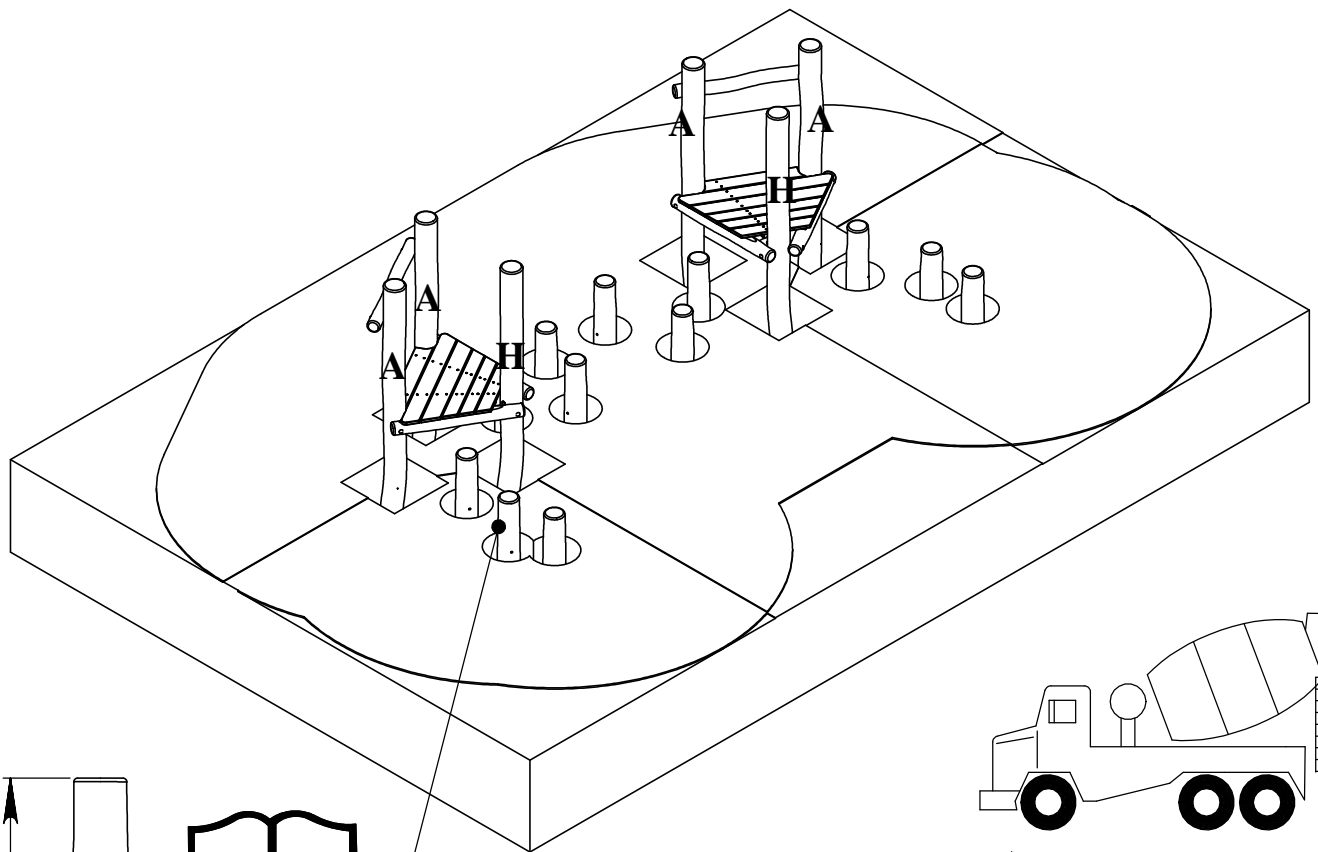

72h

4

Bij droog weer moeten alle bouten en schroeven opnieuw aangespannen worden.
 Par temps sec il faut resserrer régulièrement toute la visserie.
 By dry and warm weather check the tightness of all bolts and screws.
 Bei trockenem Wetter müssen alle Schrauben und Bolzen aufs neue angespannt werden.
 Para el tiempo seco, se necesita cerrar o ajustar los tornillos y tuercas.
 Con tempo asciutto, tutti i bulloni e le viti devono essere avvitate nuovamente.