

# *CB(T)-54CW*



## Electronic Dartboard Owner's Manual And Game Instructions RN5343

## Mounting with either batteries or adapter

Choose a location to hang the dartboard where is about 10 feet (3.048 m) of open space in front of the board. The “toe-line” should be 7’9 1/4” (2.37 M) from the face of the dartboard. Since this dartboard is powered with either an AC adapter or batteries, you could mount it anywhere or close to an electronic outlet for convenience. Remove the batteries when you use an adapter. No matter the dartboard has horizontal or vertical hang hole(s), the center of bullseye should be 5’8” (1.73 m) from the ground. Mark the center location on the wall. Measure the distance between hang hole(s) and center. Then, make the mark(s) for hang hole(s). Make sure the second mark for hang hole is level with the first mark. Mount the dartboard on the wall by lining up the hang holes on the back with the screws. It may be necessary to adjust the screws until the board fits snugly against the wall. If you want to mount the dartboard even more securely to the wall, you can fasten four screws through the holes located in the catch ring area (the area outside the scoring segments)

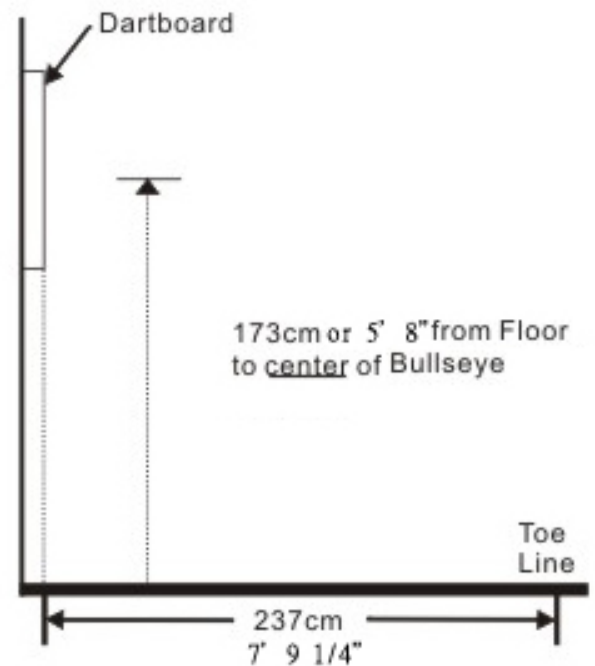

## Dartboard Functions

**POWER** switch/button - Located on the lower right corner on the side of the dartboard. Be sure the AC Adapter is plugged into the jack on the right side of the dartboard or batteries are installed. Press the POWER switch to turn game on or off.

**START/HOLD** button - This multi-function button is used to:

- START the game when all options have been selected.
- Put dartboard in HOLD status between rounds to allow player to remove darts from the target area.

**GAME GUARD** button –After the START button has been pressed and play has begun, the GAME GUARD feature can be activated. When the button is pressed, all of the keys will ‘lock’. When GAME GUARD is active, a misguided dart hitting a button will not affecting your game. To deactivate the GAME GUARD, simply press the button again and the keys will unlock.

**BOUNCE OUT** button - Decide before play if you want to count darts that do not remain in board (“bounce-outs”) or not. If not, simply press the BOUNCE OUT button immediately after a bounce out occurs to deduct the score that registers

**DART-OUT/SCORE** button - The DART-OUT feature is active only during the “01” games (301, 401, etc.). When a player’s score falls below 160, he/she can press the DART OUT button to get a suggestion from the dartboard as to the 3 darts needed to finish the game. Note: doubles and triples are indicated with 2 and 3 dashes to the left of the number respectively. The SCORE feature allows player to access score not current on display.

**SOUND** button – Sound level adjustable from 0-7 levels (8 levels).

**DOUBLE/MISS** button – This button is used to activate the Double In/Double Out and Master Out options for the “01” games. This function is only active when selecting 301, 401, etc. games. The MISS feature is active during play of any game. Press button to register a “missed” dart. Player can press when dart lands outside target area so computer registers a thrown dart.

**PLAYER/PAGE** button – This button is used at the start of each game to select the number of players you want to play the game. In addition, this button allows players to see other player scores of not on active display.

**GAME** button – Press to page through the on-screen game menu and select game.

**SELECT** button – Press to select various difficulty settings for games. Many games contain several difficulty options that can be accessed by pressing this button

**RESET** button – Press to clear display and reset dartboard to opening sound.

**CYBERMATCH** button – This exciting feature allows single player to play against the computer at one of five different levels of skill! Only 1 player can complete against the Cybermatch competitor at a time. The Cybermatch feature adds a level of competition to normally routine practice sessions.

Cybermatch Skill Levels	Level 1 (C1)	Professional
	Level 2 (C2)	Advanced
	Level 3 (C3)	Intermediate
	Level 4 (C4)	Novice
	Level 5 (C5)	Beginner

Press to activate Cybermatch feature where you can play against the computer and then press START. When play begins: the ‘human’ player throws first. After 3 darts are thrown, go to the board to take darts out and press START to change the next player (Cybermatch). Watch as the Cybermatch opponent’s dart scores are registered on the display. The dartboard will indicate the segment the Cybermatch opponent is throwing for the in Active Score Display (the ATTEMPT LED will light). Then the Active Score Display will indicate the segment that the Cybermatch opponent actually scored (the RESULT LED will light).

After the Cybermatch opponent completes his round, the board will automatically reset for the ‘human’ player. Play continues until one player wins. GOOD LUCK!

## Electronic Dartboard Operation

1. Press the **POWER** to activate dartboard. A short musical introduction is played as the display goes through power-up test.
2. Press **GAME** button until desired game is displayed.
3. Press **DOUBLE** button (optional) to select starting and/or ending on doubles or Master Out (used only in 301 - 901 games). This is explained in the game rules section.
4. Press **PLAYER** button to select the number of players (1, 2 ... 16). The default setting is 2 players. Or select Cybermatch option by pressing CYBERMATCH button.
5. Press **START/HOLD** button (red) to activate game and begin play.

6. Throw darts: When all 3 darts have been thrown, a voice command will indicate “Remove Darts” and the score will flash. The darts can now be removed without affecting the electronic scoring. When all darts are removed from the playing surface press the **START** button to go to next player. Voice command will indicate which player is up. Also, the player indicator lights will illuminate to show which player’s turn it is.

## Team Play

In addition to scoring for up to 16 players, this dartboard is capable of keeping score for team play up to a maximum of 8 two-person teams (16 individuals). To enter team play mode, press **PLAYER** button continually until a “t” appears on the display. Each team option is illustrated below:

t 2-2 2 teams, 4 individual players (1st team-players 1&3, 2nd team-players 2&4)

t 3-3 3 teams, 6 individual players (1st team-players 1&4, 2nd team-players 2&5, 3rd team-players 3&6)

t 4-4 4 teams, 8 individual players (1st team-players 1&5, 2nd team-players 2&6, 3rd team-players 3&7, 4th team-players 4&8)

etc ...

During team play, team members combine their scores to arrive at a team score.

### GAME 1: 301

This popular tournament and pub game is played by subtracting each dart from the starting total until the player reaches exactly 0 (zero). If a player goes past zero it is considered a “*Bus!*” and the score returns to where it was at the start of that round. For example, if a player needs a 32 to finish the game and he/she hits a 20, 8, and 10 (totals 38), the score goes back to 32 for the next round.

In playing the game, the double in / double out option can be chosen (double out is the most widely used option). Simply press the “**DOUBLE**” button to change this setting. The indicators will display your current setting: Note: you can adjust total score of this game.

- Double In - A double must be hit before points are subtracted from the total. In other words, a player’s scoring does not begin until a double is hit.
- Double Out - A double must be hit to end the game.
- Double In and Double Out - A double is required to start and end scoring of the game by each player.
- Master Out - A double or triple is required to finish the game.

### Dart-Out Feature (“01” games only)

This electronic dartboard has a special “**Dart Out**” feature. When a player requires less than 160 to reach zero, the estimate feature becomes active. The player can press the **DART OUT** button to view the darts necessary to throw to finish the game (reach zero exactly). Doubles and triples are indicated with 2 or 3 lines to the left of each number respectively.

### GAME 2: CRICKET

Cricket is a strategic game for accomplished players and beginners alike. Players throw for numbers best suited for them and can force opponents to throw for numbers not as suitable for them. The object of Cricket is to “close” all of the appropriate numbers before one’s opponent while racking up the highest number of points.

**Only the numbers 15 through 20 and the inner/outer bullseye are used.** Each player must hit a number 3 times to “open” that segment for scoring. A player is then awarded the number of points of the “open” segment each time he/she throws a dart that lands in that segment, provided their opponent has not closed that segment. Hitting the double ring counts as two hits, and the triple ring counts as 3 hits. Numbers can be opened or closed in any order. A number is “closed” when the other player(s) hit the open segment 3 times. Once a number has been “closed”, any player for the remainder of the game can no longer score on it.

*Winning* - The side closing all the numbers first and accumulating the highest point total is the winner. If a player “closes” all numbers first but is behind in points, he/she must continue to score on the “open” numbers. If the player does not make up the point deficit before the opposing player(s) “closes” all the numbers, the opposing side wins. Play continues until all segments are closed.

### **NO-SCORE CRICKET**

(Press SELECT button when **Cricket** is displayed) Same rules as standard Cricket except there is no point scoring. The object of this version is to be the first to simply “close” all the appropriate numbers (15 through 20 and the bullseye).

**Cricket Scoring Display:** This dartboard utilizes a dedicated scoreboard that keeps track of each player’s segment status when playing Cricket. The exclusive Tournament Cricket Scoring display on this dartboard utilizes traditional X and O style or bar style characters to track ‘marks’. When Cricket is selected, the lights on the Cricket scoreboard are not lit – they will illuminate as ‘marks’ are scored. There are 3 separate lights within each number (15 through 20 and bullseye). During play, one of the status lights will turn on as a segment is hit. If a double or triple of an active number is hit, 2 or 3 lights will turn on respectively.

### **GAME 3: SCRAM** (For 2 players only)

This game is a variation of Cricket. The game consists of two rounds. The players have a different objective in each round. In round 1, player 1 tries to “close” (score 3 hits in each segment - 15 to 20 and bullseye). During this time, player 2 attempts to rack up as many points in the segments that the other player has not yet closed. Once player 1 has closed all segments, round 1 is complete. In round 2, each player’s roles are reversed. Now, player 2 tries to close all the segments while player 1 goes for points. The game is over when round 2 is complete (player 2 closes all segments). The player with the highest point total is the winner.

### **GAME 4: CUT-THROAT CRICKET**

Same basic rules as standard Cricket except once scoring begins, points are added to your opponent(s) total. The object of this game is to end up with the fewest points. This variation of Cricket offers a different psychology to the players. Rather than adding to your own score and helping your own cause as in standard Cricket, Cut-Throat offers the benefit of racking up points for your opponent(s), digging him in a deeper hole. Competitive players will love this variation!

### **GAME 5: ENGLISH CRICKET** (For 2 players only)

This game is another variation of Cricket that requires precision dart throwing. The game consists of

two rounds. The players have a different objective in each round. During the first round, player 2 attempts to throw bullseyes – with the objective of needing 9 to complete round 1. Double bull (red center) counts as 2 scores. Any throw that hit outer single and double segment is credited to player 1's point total. For example, if player 2 throws an outer 20, a single bullseye, and an outer 7 during his/her turn, player 2 will have one bullseye subtracted from the 9 needed, and 27 points will be credited to player 1's point total. Player 2 must exhibit accurate bullseye dart throwing!

Meanwhile, player 1 attempts to score as many points as possible during this first round. Doubles and triples count 2x and 3x their respective values. However, to score points, player 1 must score over 40 points in each turn (3 throws) to amass points against player 2. Only those points over 40 are counted toward the cumulative score. Player 1 must also exhibit precision dart throwing and avoid hitting any bullseyes during this first round because any hits scored by player 1 in the bullseye area will be subtracted from player 2's needed total of 9 bullseyes. Once player 2 reaches the objective of getting 9 bullseyes, the roles are reversed for round two.

### **GAME 6: ADVANCED CRICKET**

This difficult version of cricket was developed for the advanced player. Players must close out the segments (20, 19, 18, 17, 16, 15 and bullseye) **by using only triples and doubles!** In this challenging game, doubles segments count as 1x the number, and triple segments count as 2x the number. The bullseye scoring is the same as in standard cricket. The first player to close out the numbers with the most points is the winner.

### **GAME 7: SHOOTER**

This challenging game tests the players ability to “group together” darts within a segment during each round of play. The computer will randomly select the segment the players must shoot for at the start of each round – indicated by a flashing number in the display.

Scoring is as follows:            Single segment = 1 Point                    Double segment = 2 Points  
    Triple segment = 3 Points

When the computer selects players to hit double Bullseye, the outer bull scores 2 points and the inner Bull scores 4 points. The player with the most points at the end of the rounds is the winner. Note: you can adjust number of rounds.

### **GAME8: BIG SIX**

This game allows players to challenge their opponents to hit the targets of their choice. Similar to the popular basketball game “HORSE”; however, players must *earn* the chance of picking the next target for their opponent by making a hit on the current target first.

Single 6 is the first target to hit when the game begins. Before the game starts, players must agree on how many lives will be used by pressing **SELECT** button. Within the three throws, player 1 must hit a 6 to “save” their life. After the current target is hit, the next dart thrown will determine the opponent's target. If player 1 fails to hit the current target within 3 darts, they will lose a life and a chance to determine the next target for player 2. Player 2 will shoot for the single 6 that player 1 missed – and if it is hit, he can throw for a segment for the next round. Singles, doubles and triples are all separate targets for this game.

The object of the game is to force your opponent into losing lives by selecting tough targets for your opponent to hit such as “Double Bullseye” or “triple 20” The last player with a life left is the winner.

Note: you can adjust number of lives.

### **GAME 9: OVERS**

The object of this game is to simply score higher (“over”) than your own previous three dart total score. Before play begins, players choose the amount of lives to be used by pressing the SELECT button. When a player fails to score “over” their previous three-dart total, they will lose one life. When a player “equals” the previous three dart total, a life will also be lost. The screen on the right will light off once for each life taken away. The last player with a life remaining is the winner. Note: you can adjust number of lives.

### **GAME 10: UNDERS**

This game is the opposite of “Overs”. Players must score less (“Under”) than their own previous three-dart total. The game begins with 180 (highest total possible) when the player shoots higher than his or her own previous three-dart total, they will lose a life. Each dart that hits outside the scoring area, including bounce outs will be penalized with 60 points added to your score. This will be added at the end of the round when the “START/HOLD” button is pressed. The last player with a life remaining is the winner. Note: you can adjust number of lives.

### **GAME 11: COUNT-UP**

The object of this game is to be the first player to reach the specified point total (400, 500 ...). Point total is specified when the game is selected. Each player attempts to score as many points as possible per round. Doubles and triples count 2 or 3 times the numerical value of each segment. For example a dart that lands in the triple 20 segment is scored as 60 points. The cumulative scores for each player will be displayed in the display as the game progresses. Note: you can adjust total score.

### **GAME 12: HIGH SCORE**

The rules for this competitive game are simple - Rack up the most points in three rounds (nine darts) to win. Doubles and triples count as 2x and 3x that segment’s score respectively. You can adjust number of rounds.

### **GAME 13 ROUND-THE-CLOCK**

Each player attempts to score in each number from 1 through 20 **in order**. Each player throws 3 darts per turn. If a correct number is hit, he/she tries for the next number in sequence. The first player to reach 20 is the winner. The display will indicate which segment you are shooting for. A player must continue shooting for a segment until it is hit. The display will then indicate the next segment you should shoot for. There are many difficulty settings available for this game. Each game has the same rules, the differences are detailed as follows:

**ROUND-THE-CLOCK 1** - Game starts at segment number 1

**ROUND-THE-CLOCK 5** - Game starts at segment number 5

**ROUND-THE-CLOCK 10** - Game starts at segment number 10

**ROUND-THE-CLOCK 15** - Game starts at segment number 15

Since this game does not utilize point scoring, the double and triple rings count as single numbers.

**ROUND-THE-CLOCK Double** - Player must score a Double in each segment from 1 through 20 in order.

**ROUND-THE-CLOCK Double 5** - Game starts at double segment 5

**ROUND-THE-CLOCK Double 10** - Game starts at double segment 10

**ROUND-THE-CLOCK Double 15** - Game starts at double segment 15

*ROUND-THE-CLOCK Triple* - Player must score a Triple in each segment from 1 through 20 in order.

*ROUND-THE-CLOCK Triple 5* - Game starts at triple segment 5

*ROUND-THE-CLOCK Triple 10* - Game starts at triple segment 10

*ROUND-THE-CLOCK Triple 15* - Game starts at triple segment 15

#### GAME 14: KILLER

This game will really show who your friends are. The game can be played with as few as two players, but the excitement and challenge builds with even more players. To start, each player must select his number by throwing a dart at the target area. The display will indicate "SEL" at this point. The number each player gets is his assigned number throughout the game. No two players can have the same number. Once each player has a number, the action starts.

Your first objective is to establish yourself as a "Killer" by hitting the double segment of your number. Once your double is hit, you are a "Killer" for the rest of the game. Now, your objective is to "kill" your opponents by hitting their segment number until all their "lives" are lost. The last player to remain with lives is declared the winner. It is not uncommon for players to "team up" and go after the better player to knock him out of the game. Note: you can adjust number of lives. In addition, for those who really want a challenge, there are three additional difficulty settings: Doubles 3 lives, Doubles 5 lives, and Doubles 7 lives. In these games, you can only "Kill" opponents by scoring doubles in their number segment.

#### GAME 15: DOUBLE DOWN

Each player starts the game with 40 points. The object is to score as many hits in the active segment of the current round. The first round, the player must throw for the 15 segment. If no 15's are hit, his score is cut in half. If some 15's are hit, each 15 (doubles and triples count) is added to the starting total. The next round players throw for the 16 segment and hits are added to the new cumulative point total. Again, if no hits are registered, the point total is cut in half.

Each player throws for the numbers as indicated in the chart below in order (the screen will indicate the active segment in which to throw). The player who completes the game with the most points is the winner.

	15	16	D	17	18	T	19	20	B	TOTAL
Player 1										
Player 2										

Any Double
Any Triple

#### GAME 16: FORTY ONE

This game follows similar rules as standard Double Down as described above with two exceptions. First, instead of going from 15 through 20 and bullseye, the sequence is reversed which will be indicated on the display. Second, an additional round is included toward the end in which players must attempt to score three hits that add up to 41 points (20, 20, 1; 19, 19, 3; D10, D10, 1: etc.). This "41" round adds an extra level of difficulty to the game. Remember, a player's score is cut in half if not successful, so the "41" round presents quite a challenge!



	20	19	D	18	17	T	16	15	41	B	TOTAL
Player 1											
Player 2											

Any Double

Any Triple

"41" Round

### GAME 17: ALL FIVES

The entire board is in-play for this game (all segments are active). With each round (of 3 darts) each player has to score a total which is divisible by 5. Every "five" counts as one point. For example 10, 10, 5 = 25. Since 25 is divisible by 5 fives, this player scores 5 points ( $5 \times 5 = 25$ ).

If a player throws 3 darts that are not divisible by 5, no points are given. Also, the last dart of each round must land in a segment. If a player throws the third dart and it lands in the catch ring area (or misses the board completely), he earns no points even if the first two darts are divisible by 5. This prevents a player from "tanking" the third throw if his first two are good. The first player to total fifty-one (51) "fives" is the winner. The screen will keep track of the point totals. Note: you can adjust number of 5 you need to get.

### GAME 18: SHANGHAI

Each player must progress around the board from 1 through 20 in order. Players start at number 1 and throw 3 darts. The object is to score the most points possible in each round of 3 darts. Doubles and triples count toward your score. The player with the highest score after completing all twenty segments is the winner.

Adjustable Difficulty Settings for Shanghai include the following options:

- SHANGHAI 1 - Game starts at segment 1
- SHANGHAI 5 - Game starts at segment 5
- SHANGHAI 10 - Game starts at segment 10
- SHANGHAI 15 - Game starts at segment 15

In addition, Super Shanghai is more difficult. The game is only 7 rounds. This rule is similar as described above except that specific targets needs to be hit in 3 darts, or the score will become zero.

- SUPER SHANGHAI 1 - Game starts at segment 1, ends at segment 7. Specific targets are 3 and 5.
- SUPER SHANGHAI 5 - Game starts at segment 5, ends at segment 11. Specific targets are 7 and 9.
- SUPER SHANGHAI 10 - Game starts at segment 10, ends at segment 16. Specific targets are 12 and 14.
- SUPER SHANGHAI 15 - Game starts at segment 15, ends at segment 25. Specific targets are 17 and 19.

### GAME 19: GOLF

This is a dartboard simulation of the game golf (but you don't need clubs to play). The object is to complete a round of 9 through 18 "holes" with the lowest score possible. The Championship "course" consists of all par 3 holes making par 27 for a nine hole round or 54 for a round of 18.

The segments 1 through 18 are used with each number representing a "hole." You must score 3 hits in each hole to move to the next hole. Obviously, double and triples affect your score as they allow you to finish a hole with fewer strokes. For example, throwing a triple on the first shot of a hole it is counted as an "eagle" and that player gets a complete that hole with 1 "stroke."

Note: The active player continues to throw darts until he “holes out” (scores 3 hits on the current hole). The voice announcer will indicate the player that is up - listen carefully to avoid shooting out of sequence. By the way, there are no “gimmes” in this game!

## GAME 20: FOOTBALL

Strap your helmet on for this game! The first thing necessary is to select each player’s “playing field.” This can be done by throwing a dart or by manually pressing a segment on the board by each player. This is entirely up to you, but whichever segment is selected becomes your starting point which carries through the bullseye and directly across to the other side of the bullseye (see diagram). The First player to “score” is the winner. The display will keep track of your progress and indicate the segment you need to throw for next.

For example, if you select the 20 segment, you start on the double 20 (outer ring) and continue all the way through to the double 3. The “field” is made up of 11 individual segments and must be hit in order. So, keeping with the example above, you must throw darts in the following segments in this order: Double 20 ... Outer Single 20(Rectangle) ... Triple 20 ... Inner Single 20(Triangle) ... Outer Bullseye ... Inner Bullseye ... Outer Bullseye ... Inner Single 3(Triangle) ... Triple 3 ... Outer Single 3 (Rectangle) ... and finally a Double 3.

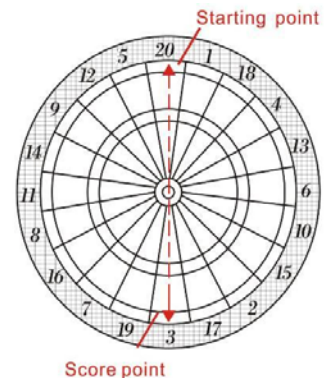

## GAME 21: BASEBALL

This dartboard version of baseball takes a great deal of skill. As in the real game, a complete game consists of 9 innings. Each player throws 3 darts per “inning.” Inning 1 will use segment 1 and so on. Player needs to hit the specific segment to run. The field is laid out as shown in the diagram. Once player runs to home base, he/she scores 1 point.

### Segment

### Result

Singles segments	“Single” - One base
Doubles segment	“Double” - Two bases
Triples segment	“Triple” - Three bases
Bullseye	“Home Run” ( <i>can only be attempted on third dart of each round</i> )

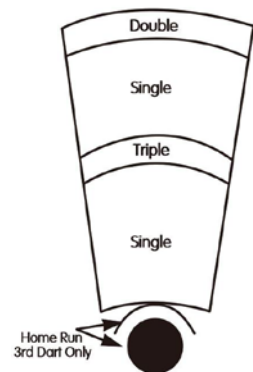

The object of the game is to score as many points as possible each inning. The player with the highest point at the end of the game is the winner.

Adjustable Difficulty Settings for BASEBALL include 6 rounds and 9 rounds. Each option is played exactly as outlined above with the exception of the number of round it takes to win the game.

## GAME 22: STEEPLECHASE

The object of this game is to be the first player to finish the “race” by being the first to complete the “track.” The track starts at the 20 segment and runs clockwise around the board to the 5 segment and ends with a bullseye. Sounds easy right? What has not yet been specified is that you must hit the inner single segment (Triangle) of each number to get through the course. This is the area between the bullseye and the triples ring. And, as with a real steeplechase, there are obstacles throughout the course to hurdle. The four hurdles are found at the following places: (Hit the appointed segment to pass the hurdles)

<input type="checkbox"/> <input type="checkbox"/> 1st fence	Triple 13	<input type="checkbox"/> 2nd fence	Triple 17
<input type="checkbox"/> <input type="checkbox"/> 3rd fence	Triple 8	<input type="checkbox"/> 4th fence	Triple 5

The first player to complete the course and hit the bullseye wins the race.

### GAME 23: BOWLING

This dartboard adaptation of bowling is a real challenge! It is a difficult game in that you must be very accurate to rack up a decent score. Player one starts the game. You must select your “alley” by either throwing dart or manually pressing *Diagram* segment of choice. Once alley is selected, you have 2 remaining darts to throw in which to score points or “pins.” Each specific segment in your “alley” is worth a given pin total:

<u>Segment</u>	<u>Score</u>
Double	9 pins
Outer Single	3 pins
Triple	10 pins
Inner Single	7 pins

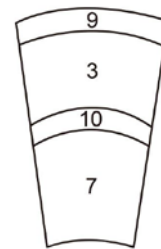

There are several rules for this game as follows:

1. A perfect game score would be 200 in this version of bowling. The game includes 10 rounds. The highest score is the winner.
2. You cannot hit the same singles segment twice within the same “frame” (round). The second hit will count as zero points. *Hint: Try to hit each single to reach 10 points in the frame.*
3. You can score 20 points per “frame” by hitting the triple segment twice.
4. If your first dart hits a Double segment, your second dart hits a Double too and the third dart hit any segment, you will score 10 pins (point) for this round.
5. If your first dart hits a Double segment, your second dart hits an Outer or Inner Single segment and the third dart hit the Double, this round will only score 9 points.
6. If your first dart hits a Double segment, your second dart hits a Triple and the third dart hit a Double segment, you will score 19 points total.

### GAME24: CAR RALLYING

This game is similar to steeplechase except we let you set up your own “race track.” You can set up as many obstacles as you wish.

Before the game starts, the display will prompt you to select the course (“SEL”). Players should alternate selecting segments by pressing on the specific segment of your choice. Note: You will have to hit the exact segment you selected to move on during the race. If you choose inner single 20, that inner single area will need to be hit during the race. The display will indicate inner single with a line next to the bottom of the 1, an outer single is shown with a line next to the top portion of the 1.

Obstacles usually comprise hitting a difficult number before continuing on the racetrack. Again, the route can be made as difficult or easy as you wish and can go anywhere on the target area of the board. After the track is selected, press START to begin the race. The first player to complete the course is the winner.

### GAME 25: SHOVE A PENNY

Only the numbers 15 through 20 and the bullseye are used. Singles are worth 1 point, doubles are

worth 2, and triples are worth 3 points. Each player must throw for the numbers in order with the objective of scoring 3 points in each segment to move on to the next. If a player scores more than 3 points in any one number, the excess points are given to the next player. The first player to score 3 points in all segments (15 - 20 and bull) is the winner.

### GAME 26: NINE-DART CENTURY

The object of this game is to attempt to score 100 points, or come as close as possible, after 3 rounds (9 darts). Doubles and triples count as 2x and 3x their value respectively. Going over 100 points is considered a "bust" and causes you to lose unless all players go over. In that case, the player closest to 100 wins (player that scored the lowest amount over 100).

### GAME 27: GREEN VS. RED (2 players only)

This game is a race around the board, where skill at hitting doubles and triples pays off with victory. Player 1 is "green" and player 2 is "red." Player 1 shoots for only doubles and triples that are green and works around the board clockwise. Player 2 starts at 20 and works around the board counter-clockwise, shooting for red segments (the temporary score display will indicate which segment to throw for). Note: a maximum of one double and one triple of the same number can be scored in a single round. What's more, hitting the wrong number (of your opponent's color) **subtracts** that amount from your score - so be careful. The player with the most points after completion of the game is the winner.

Player 1: Green

Double and triple of	1	4	6	15	17	19	16	11	9	5	B
----------------------	---	---	---	----	----	----	----	----	---	---	---

Player 2: Red

Double and triple of	20	12	14	8	7	3	2	10	13	18	B
----------------------	----	----	----	---	---	---	---	----	----	----	---

Note: Please use above chart to determine player 1 and player 2 if your dartboard segment color is not red and green.

### GAME 28: GOLD HUNTING

The object of this game is to find "gold." You collect gold for each 50 points. Gold is only collected only if your score is exactly 50 or a multiple of 50 (100, 150, etc.) at any point during a round. The player who reaches to selected total gold required first is the winner.

### GAME 29: CASINO A - FLUSH

This game, inspired by casino play, tests your nerve and skill as you gamble points to defeat your opponent. The object of the game is to be the first player to reach the designated point total. Note: you can adjust the end-game point total.

The dartboard will indicate the number you must throw for. The default "bet" is 10 points. However, each player can increase his bet at the start of each round to 20, 30, 40 ... 90 points. Players usually wager high when a number appears they are confident in hitting. To change your bet (at start of a round), press the **BOUNCE OUT** button. Your new bet will be indicated in the display (for example, "b20" will appear to indicate a bet of 20 points). The bet will automatically revert to 10 points at the start of each round.

To "cash in" on your bet, you need to hit the indicated number segment. Hitting a single on the first throw is a "push" and does not score points. However throwing a double or triple of the correct segment on the first throw counts as 1x and 2x your bet respectively. Your next two darts in the round

count as 1x, 2x, and 3x your bet for a single, double, or triple. The segment scoring display will light to indicate the number of successful hits you have registered. Failing to hit the active segment in a round costs you the value of the bet you selected at the start of the round. The first player to reach the designated point total is the winner.

### **GAME 30: CASINO B - STRAIGHT**

This game, while similar to Casino A, has an added element of play. Again, the object of the game is to be the first player to reach the designated point total. Note: you can adjust the end-game point total.

The dartboard will indicate the number you must throw for. The default “bet” is 10 points. However, each player can increase his bet at the start of each round to 20, 30, 40 ... 90 points. Players usually wager high when a number appears they are confident in hitting. To change your bet (at start of a round), press the **BOUNCE OUT** button. Your new bet will be indicated in the display (for example, “b20” will appear to indicate a bet of 20 points). The bet will automatically revert to 10 points at the start of each round.

To “cash in” on your bet, you need to hit the indicated number segment. Hitting a single on the first throw is a “push” and does not score points. However throwing a double or triple of the correct segment on the first throw counts as 1x and 2x your bet respectively. **This is where the new element comes into play.** Instead of throwing for the same segment during each round, your sequence is to span across the target area. For example, if the display indicated to throw for segment 1, you attempt to throw for segment 1, followed by a bullseye, followed by segment 19. The temporary score display will indicate segment to aim for after each throw.

Your next two darts in the round count as 1x, 2x, and 3x your bet for a single, double, or triple (bullseye segment has no triple area). The segment scoring display will light to indicate the number of successful hits you have registered. Failing to hit the active segment in a round costs you the value of the bet you selected at the start of the round. The first player to reach the designated point total is the winner.

### **GAME 31: CASINO C - 3-STAR**

This version of Casino is very difficult, as you need to score at least 3 hits in the active segment during each round to score points. Again, the object of the game is to be the first player to reach the designated point total. Note: you can adjust the end-game point total.

Only the segments 15 through 20 and bullseye are active in this game. The segment scoring display will be lit at the start of each round. The default “bet” is 10 points. However, each player can increase his bet at the start of each round to 20, 30, 40 ... 90 points. Players usually wager high when a number appears they are confident in hitting. To change your bet (at start of a round), press the **BOUNCE OUT** button. Your new bet will be indicated in the display (for example, “b20” will appear to indicate a bet of 20 points). The bet will automatically revert to 10 points at the start of each round.

To “cash in” on your bet, you need to hit an active segment (15 - 20 and bullseye) 3 times or score a triple “opens” the segment for scoring and that player receives 3 times the value of his bet. Doubles and triples count as 2 and 3 hits respectively. Failing to hit a segment 3 times forces that player to lose the value of his bet. Also, hits within segments are **not** carried over to the next round. The first player to reach the designated point total is the winner.

### **GAME 32: ELIMINATION**

The object of the game is to “Eliminate” your opponents. The rules are very simple. Each player must score higher total points with 3 darts than the opponent before them. Each player starts with 3 lives. If the player fails to score higher total points than the previous opponents score, they lose one life. Tie scores will also result in a lost life. The winner is the last player with lives remaining. Note: you can adjust number of lives.

### GAME 33: HORSESHOES

This 2 -player game uses only the 20 and 3 segments to represent the two horseshoe pits. Player 1 will shoot at the 20 segment and Player 2 will shoot at the 3 segment. Scoring is cumulated per round. First player to score 15 points is the winner.

Scoring is as follows:

TRIPLE RING = Ringer 3 points  
DOUBLE RING= Leaner 2 points

INNER SINGLE SEGMENT (Triangle) = 1 point  
OUTER SINGLE SEGMENT (Rectangle) = 0 point

Scores will only count for the player or team with the most points in that round. For example, if player 1 scores 3 points and player 2 scores 1 point, only player 1 will awarded 3 points for that round. Rounds continue until 15 points are scored. Note: you can adjust the end-game point total.

### GAME 34: WARFARE

In this 2-player game, the dartboard is a battleground divided into two halves. The first player to hit all of the opposing segments (armies) wins the game. Segments do not have to be hit in order.

Player 1 is the “TOP” army and shoots darts at the bottom sections of the board.

Player 1 needs to hit bottom segments (6, 10, 15, 2, 17, 3, 19, 7, 16, and 8)

Player 2 is the “BOTTOM” army and shoots for the top section of the dartboard

Player 2 needs to hit top segments (11, 14, 9, 12, 5, 20, 1, 18, 4, and 13)

Adjustable difficulty settings are as follows:

*BATTLEGROUND DOUBLES:*

- Players shoot for double segments only to eliminate opponent’s armies

*BATTLEGROUND TRIPLES:*

- Players shoot for triple segments only to eliminate opponent’s armies

*BATTLEGROUND with GENERALS*

This variation of the game includes one more obstacle to accomplish. Players must capture the “general” after all segments (armies) have been hit to win the game. One hit on the bullseye will capture the general. Hits to the bullseye will not count if all segments are not first closed.

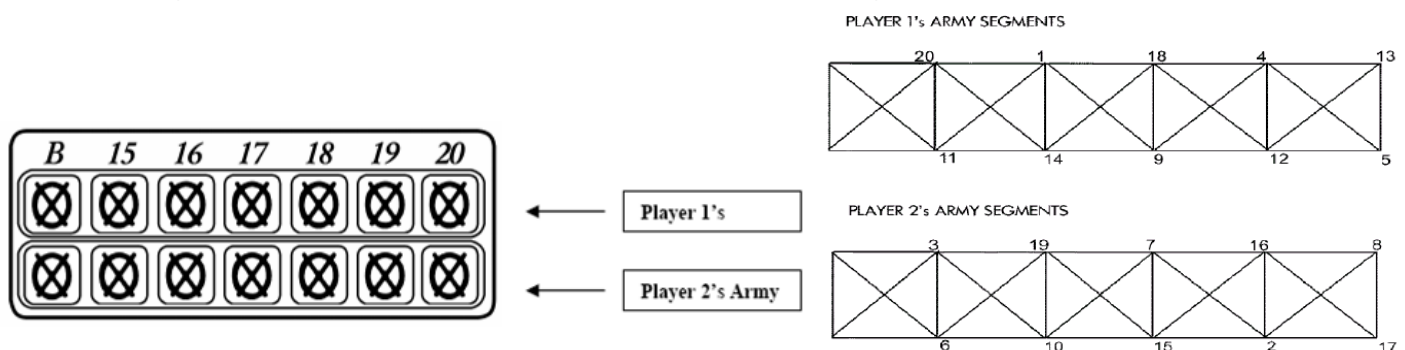

The top cricket scoring display on the dartboard shows player 1’s army segments. Player 2’s army segments are in the second row. Each time a segment is hit, the corresponding light will shut off. Follow the scoreboard map on the next page to keep track of which segments you need to hit to win.

### GAME 35: ADVANCED WARFARE

The rules are the same as standard Battleground except now there are land mines on the battlefield!

Players must be careful to avoid the land mines located in the Triple and Double rings of opponents segment numbers.

Any player that hits a double or triple ring on the opposing teams' battlefield will lose an army of his or her own. For example, if player 1 mistakenly hit the triple ring of the "6" segment, they would lose their own army at the "11" segment.

### GAME 36: PAINTBALL

This game is similar to "Battleground" except there is an alternative way to win the battle other than just hitting the opposing teams' armies segments. As in the real game of paintball, players can also capture the opposing team's flag to win the game. To capture the flag, the double bullseye must be hit 3 times to capture the opposing teams' flag! Single bullseye will not count towards the 3 needed to capture the flag. Double bullseyes do not have to be scored in the same round and will be tallied during the game. First player to either capture the flag or eliminate the opposing army is the winner.

#### *Adjustable Difficulty Settings*

- Paintball Doubles Players must either hit 3 double bullseyes to capture the flag or hit double ringed segments to eliminate armies.
- Paintball Triples Players must either hit 3 double bullseyes to capture the flag or hit triple ringed segments to eliminate armies.

### GAME 37: FOX HUNT

This is a very challenging 2-player game that is best suited for players of advanced skill. One player will play the role of the cat and the other will be the mouse. The object of the game is for the mouse to get back to his hole before being caught by the cat. The mouse starts first from the "20" segment and proceeds counter-clockwise around the dartboard by hitting first the double segment and then the single of each segment. The cat starts back at the "18" segment and proceeds counter clockwise around the dartboard to catch the mouse by hitting doubles only of each segment. If the mouse makes it all the way around the board back to the double 20, the mouse wins the game. If the cat hits the double segment that the mouse is on, the cat has caught the mouse and has won the game.

### GAME 38: TIC-TAC TOE

Using the specified dartboard segments, the object of the game is to close out numbers to gain an X or an O. Traditional tic-tac-toe rules apply. Three X's or O's in a row horizontally, diagonally, or vertically will win the game. In order to place an X or O in one of the boxes, a player needs to score 3 times within that segment. (Double and triple rings count) (B is the Bullseye) The number of hits on each segment will be displayed on the screen. One hit to the segment will show "\ " Two hits will show "X" A closed segment will display either an " ⊗ " or "O" depending on which player is scoring. Use the map below as a guide during play.

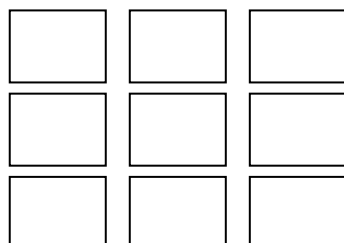

## Caring for your Electronic Dartboard

1. Never use metal tipped darts on this dartboard. Metal tipped darts will seriously damage the circuitry and electronic operation of this dartboard.
2. Do not use excessive force when throwing darts. Throwing darts too hard will cause frequent tip breakage and cause excess wear on the board.
3. Turn darts clockwise as you pull them from the board. This makes it easier to remove darts and extends the life of the tips.
4. Use only the A/C adapter that comes with the dartboard. Using the wrong adapter may cause electrical shock and damage to the electronic circuits.
5. Remove the batteries when not in use or if using the optional A/C adapter. This will prolong the life of your batteries.
6. Do not spill liquids on the dartboard. Do not use spray cleaners, or cleaners that contain ammonia or other harsh chemicals as they may cause damage.

## Important Notes

### Stuck Segment:

Occasionally, a dart will cause a segment to become wedged within the segment separator web. If this happens, all games will be suspended and the LCD display will indicate the segment number that is stuck.

To free the segment, simply remove the dart or broken tip from the segment. If the problem is still not solved, try wiggling the segment until it is loose. The game will then resume where it left off.

### Broken Tips:

From time to time a tip will break off and become stuck in the segment. Try to remove it with a pair of pliers or tweezers by grasping the exposed end and pulling it out of the segment. If this is not possible, you can attempt to push the tip through to the back of the segment. Use a nail that is smaller than the hole and gently push the tip until it falls through the other side. Be careful not to push too far and damage the circuitry behind the segment. Don't be alarmed if tips break. This is a normal occurrence when playing soft tip darts. We included a pack of replacement tips which should keep you supplied for quite some time. When replacing tips, make sure you use the same type of tips that come with this dartboard.

### Darts:

It is recommended that you use the enclosed darts on this dartboard. Using other darts may cause damage to the segment and electronic circuit. Replacement tips are available at most retailers carrying dart products

### Cleaning The Electronic Dartboard:

Your electronic dartboard will provide many hours of competition if cared for properly. Regular dusting of the cabinet is recommended using a damp cloth. A mild detergent can be used if necessary. The use of abrasive cleaners or cleaners that contain ammonia may cause damage and should not be used. Avoid spilling liquid onto the target area since it can result in permanent damage and is not covered by the warranty.



## Game Menu

G01	301	G20	Football
G02	Cricket	G21	Baseball
G03	Scram	G22	Steeple chase
G04	Cut Throat	G23	Bowling
G05	Eng Cri	G24	Car Rally
G06	Adv-Cri	G25	Shove Pen
G07	Shooter	G26	Nine Darts
G08	Big Six	G27	G & R
G09	Overs	G28	Gold Hunt
G10	Unders	G29	Cas-A
G11	Count Up	G30	Cas-B
G12	High Score	G31	Cas-C
G13	Round Clk	G32	Elimination
G14	Killer	G33	Horse She
G15	Doub DN	G34	Warfare
G16	41	G35	Adv War
G17	All Fives	G36	Paintball
G18	ShangHai	G37	Fox Hunt
G19	Golf	G38	Tic-Tac-Toe

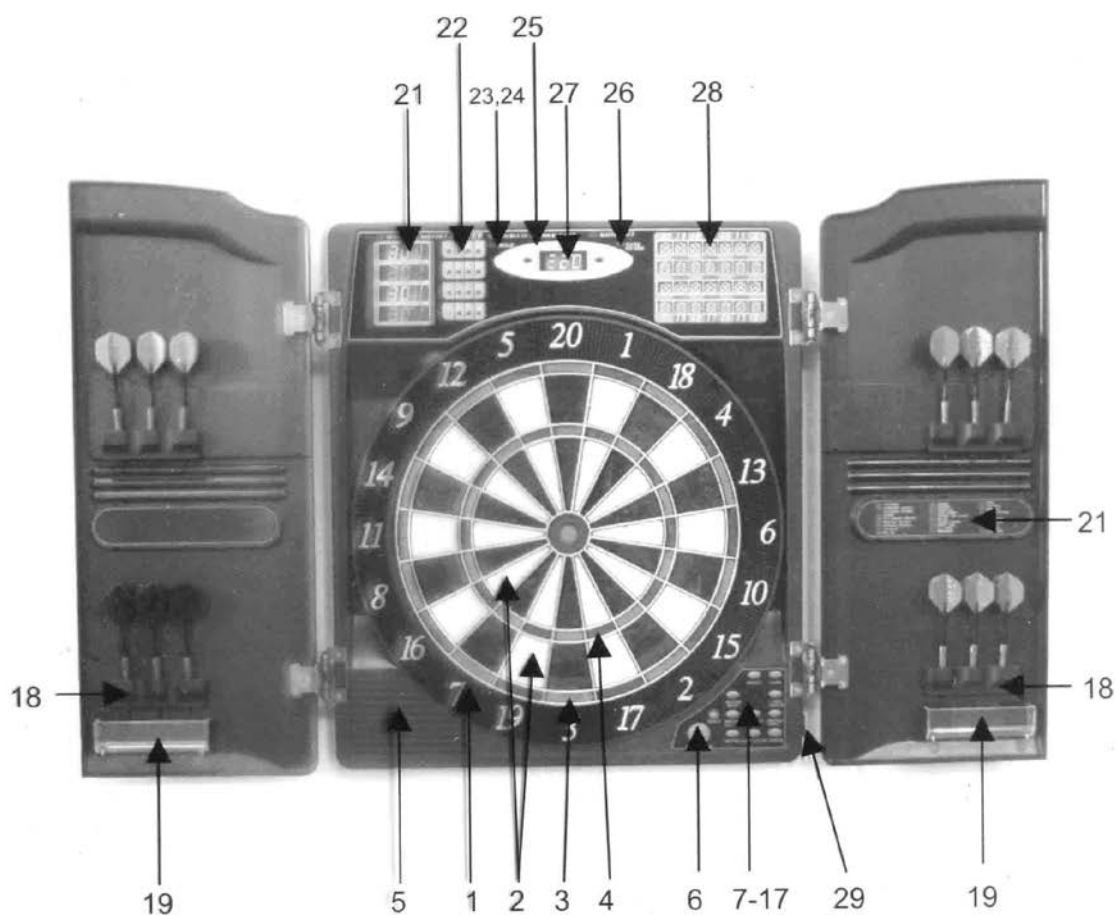

1. Catch Ring
2. Singles Ring
3. Doubles Ring
4. Triples Ring
5. Speaker
6. Start/Hold button
7. Reset button
8. Player/Page button
9. Bounce Out button
10. Sound button
11. Select button

12. Dart Out/Score button
13. Game Guard button
14. Power button
15. Double/Miss button
16. Cybermatch button
17. Game button
18. Built-in Dart Holders
19. Storage Drawer
20. Game Menü
21. Score Display Indicators

22. Players Indicators
23. Hold Indicators
24. Double In Indicators
25. Double Out Indicators
26. Master Out Indicators
27. Temporary Score Display
28. Cricket Scoring Display
29. Adapter Jack