

A610

KONING ARTHUR
LE ROI ARTHUR
KÖNIG ARTHUR
KING ARTHUR
REY ARTURO
RE ARTU

Montagehandleiding

Notice de montage

Assembling manual

Montageanleitung

Instrucciones para el montaje

Istruzioni di installazione

Leeftijd:

Age:

Age group:

Alter:

Edad:

Età: 4-15

EUROPLAY nv

Eegene 9

B-9200 DENDERMONDE

tel. 32.52.22 66 22

fax.32.52.22 67 22

www.europlay.eu

Dat.: 31/01/2014

Page: 1/4

Art.Nr. 2266204

VALHOOGTE / HAUTEUR DE CHUTE /
FALL HEIGHT / FALLHÖHE/
ALTURA DE CAÍDA / ALTEZZA DI CADUTA

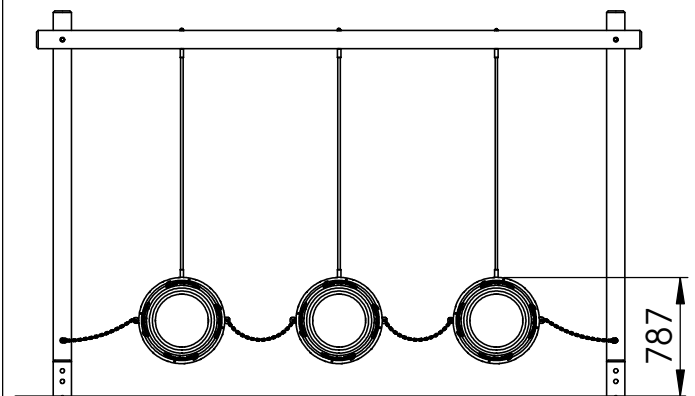
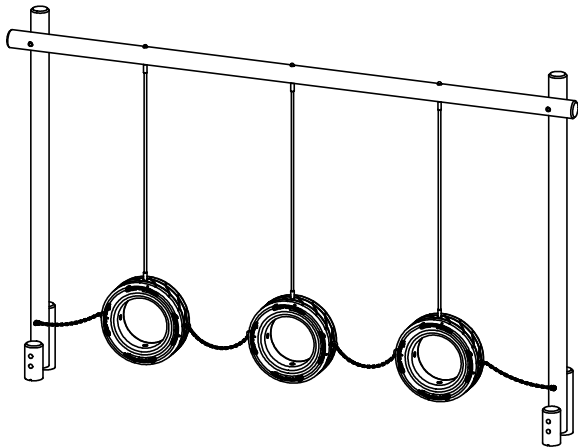

VEILIGHEIDSAFSTAND / ESPACE DE CHUTE / SAFETY AREA /
SICHERHEITSAFSTAND / ZONA DE SEGURIDAD / DISTANZA DI SICUREZZA

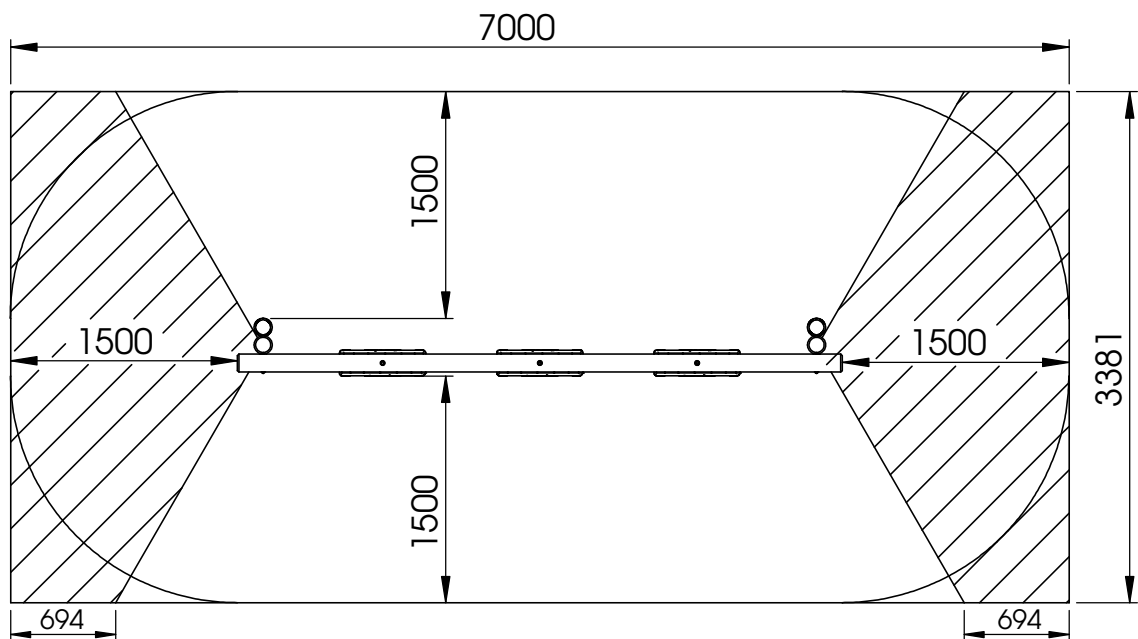

AFMETINGEN
DIMENSIONS
MASSE
DIMENSIONES
DIMENSIONI
L: 3990
H: 2550
Br: 390

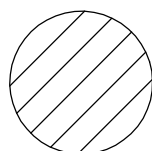

Samenvoegingszone avonturenpad
Zone de liaison parcours d'aventures
Verbindungsfeld survival parcours
Linking zone adventure path
Zona de conexión recorrido aventurero
Zona di allineamento percorso d'avventura

Benodigdheden - Liste des pièces - Materials - Benötigtes - Accesorios - Requisiti

1x		22kg
2x		14kg
2x		22kg
2x		22kg
		L309
		±530
2x		M12 x 250
		Ø10 + M5
		6x
2x		M12 x 230
4x		M12 x 340
		15 + M6
		2x
14x		M12
18x		M12
		M12
		20x

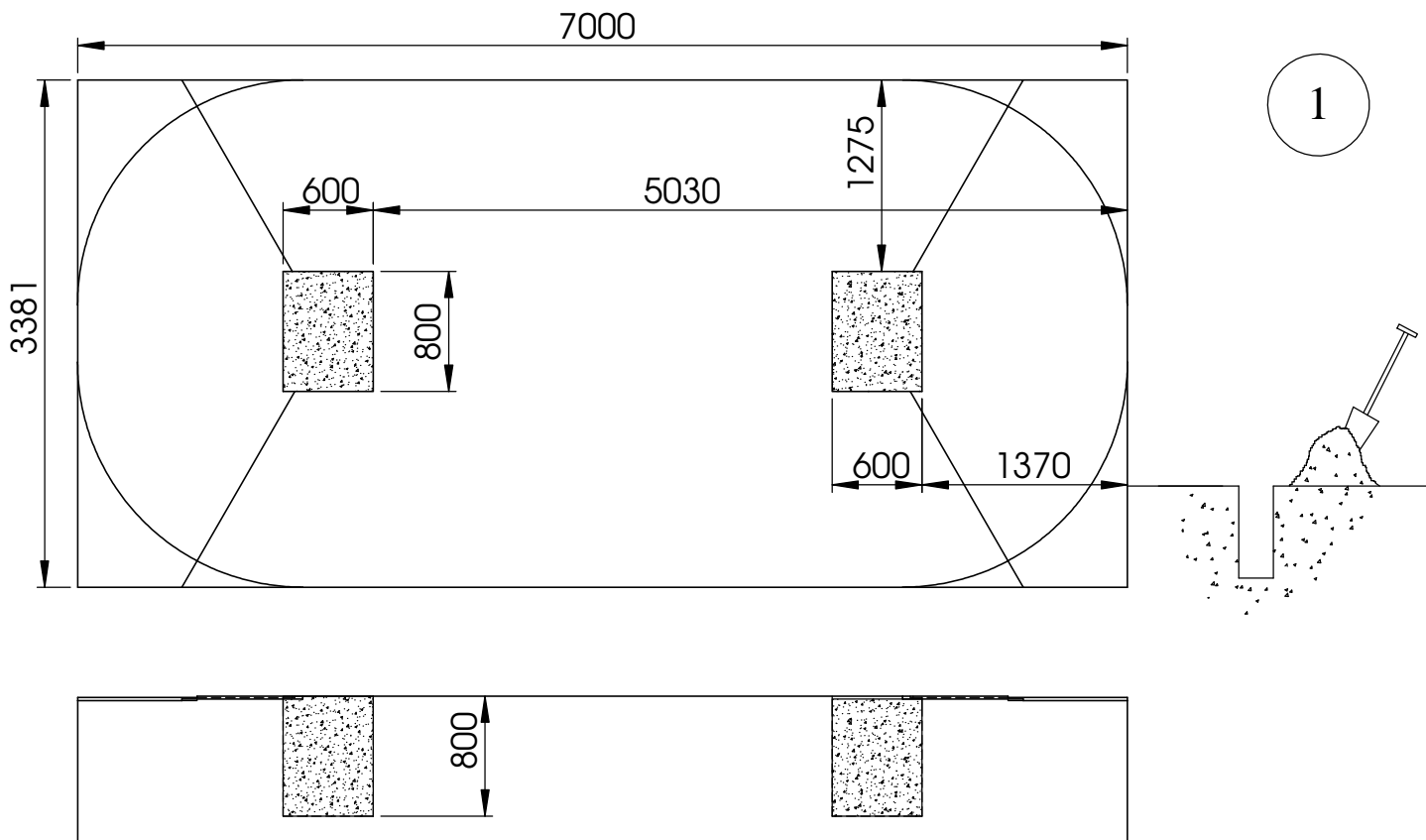

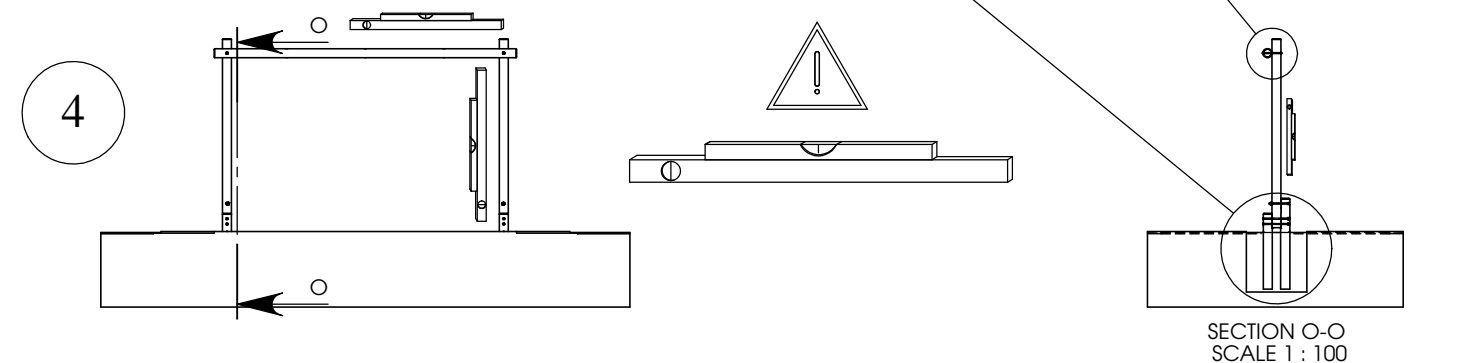
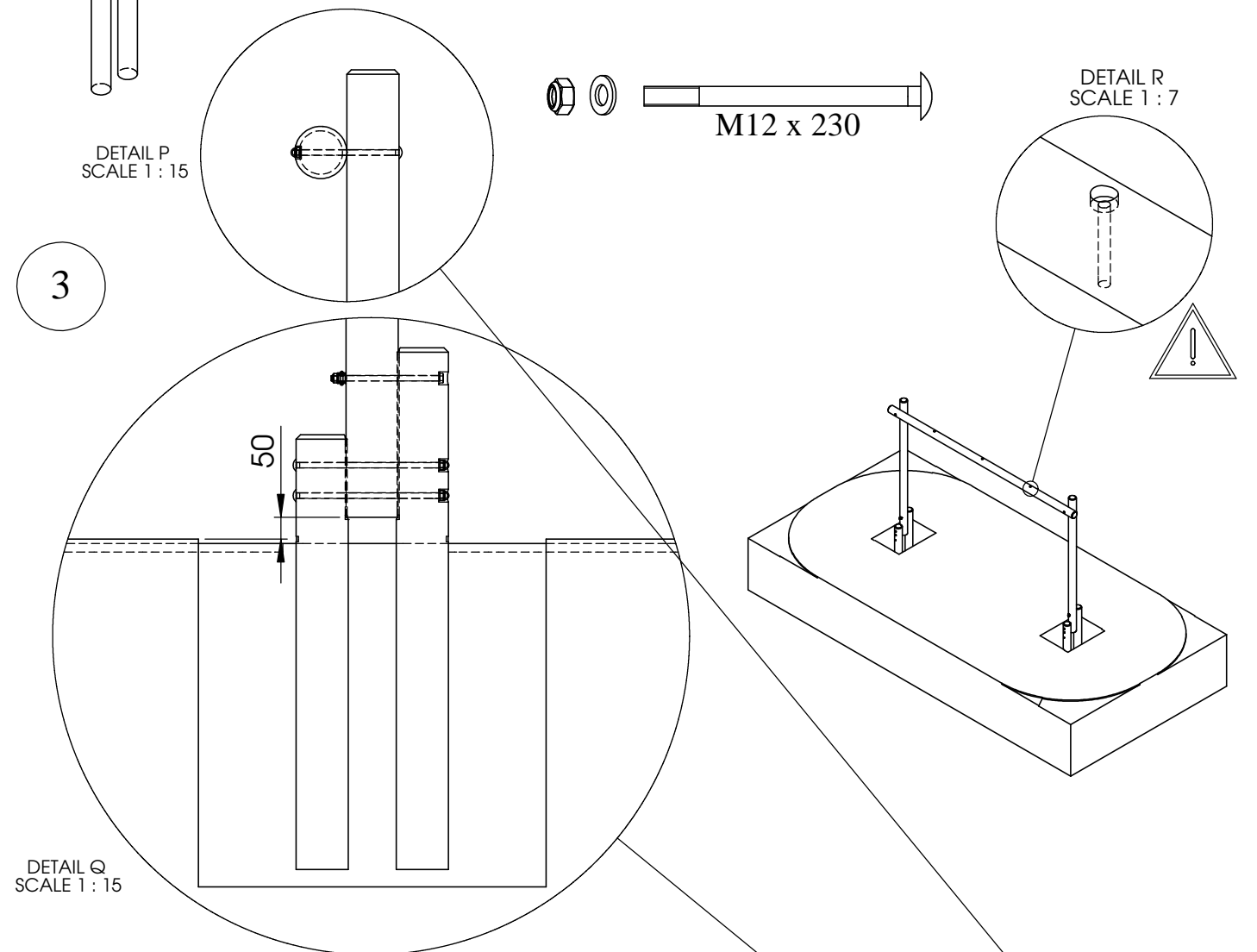
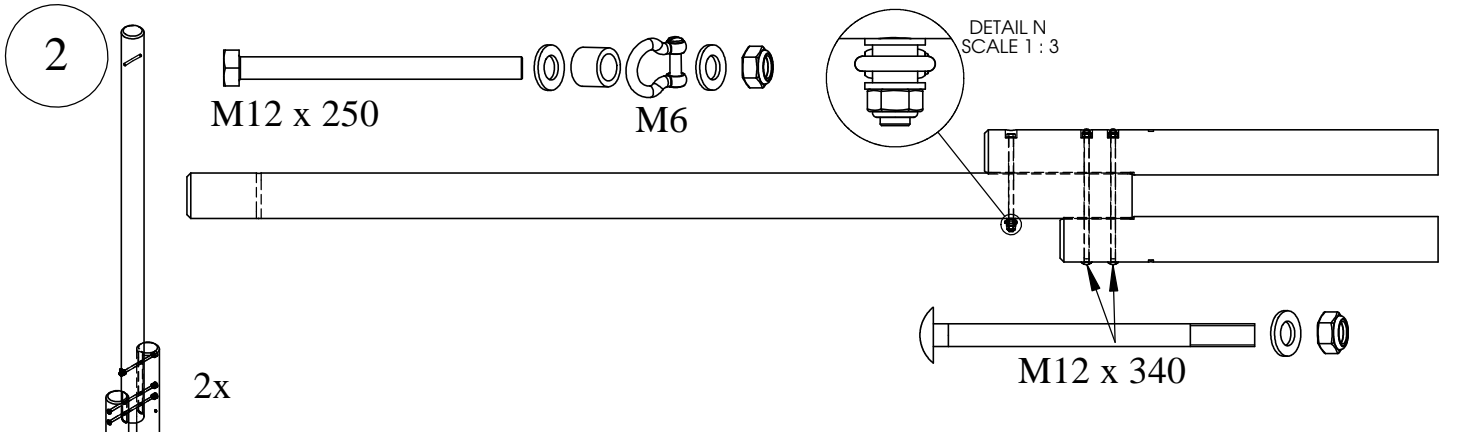

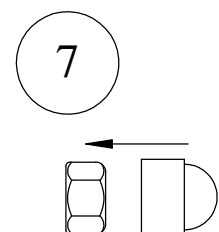
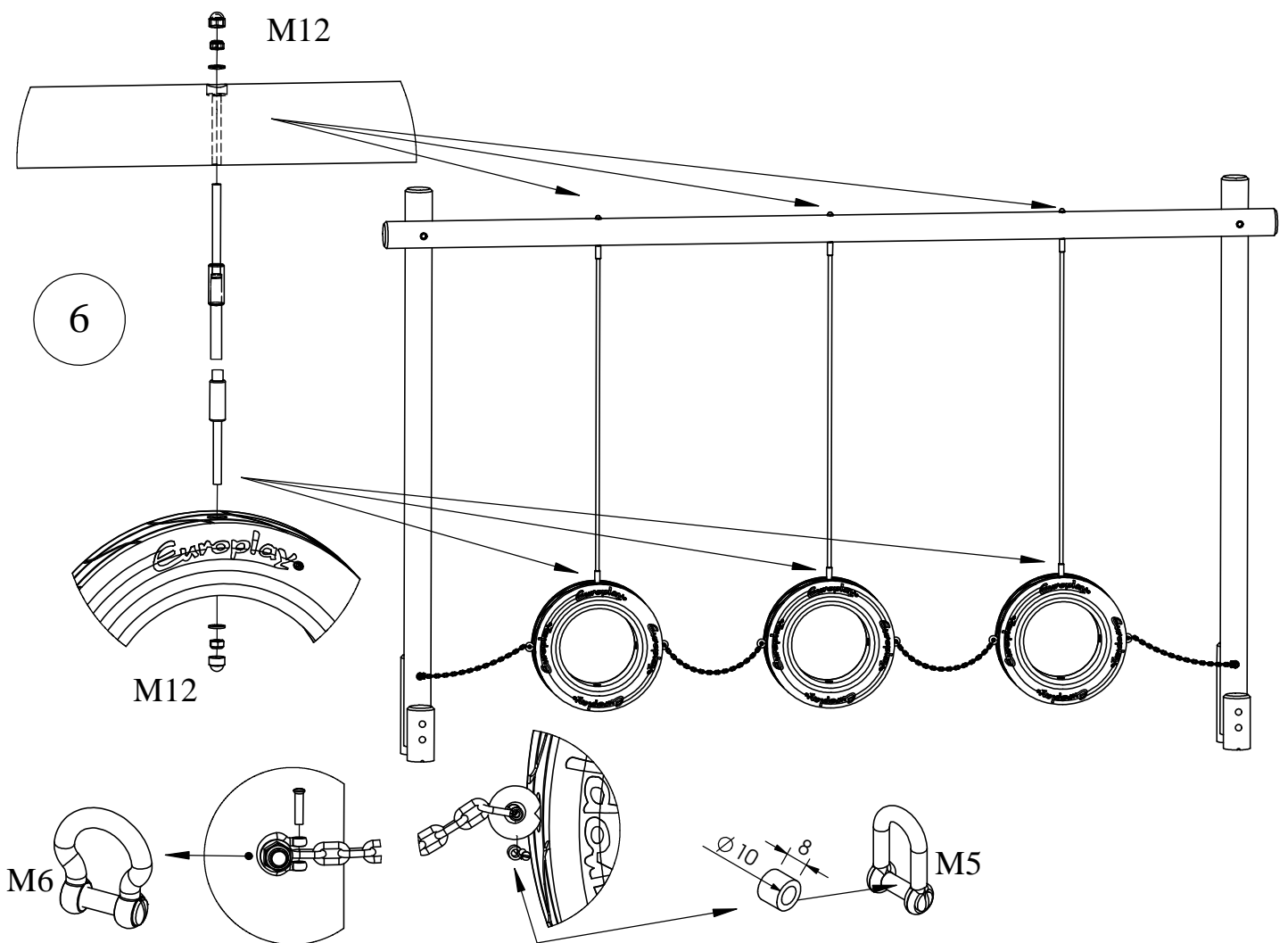
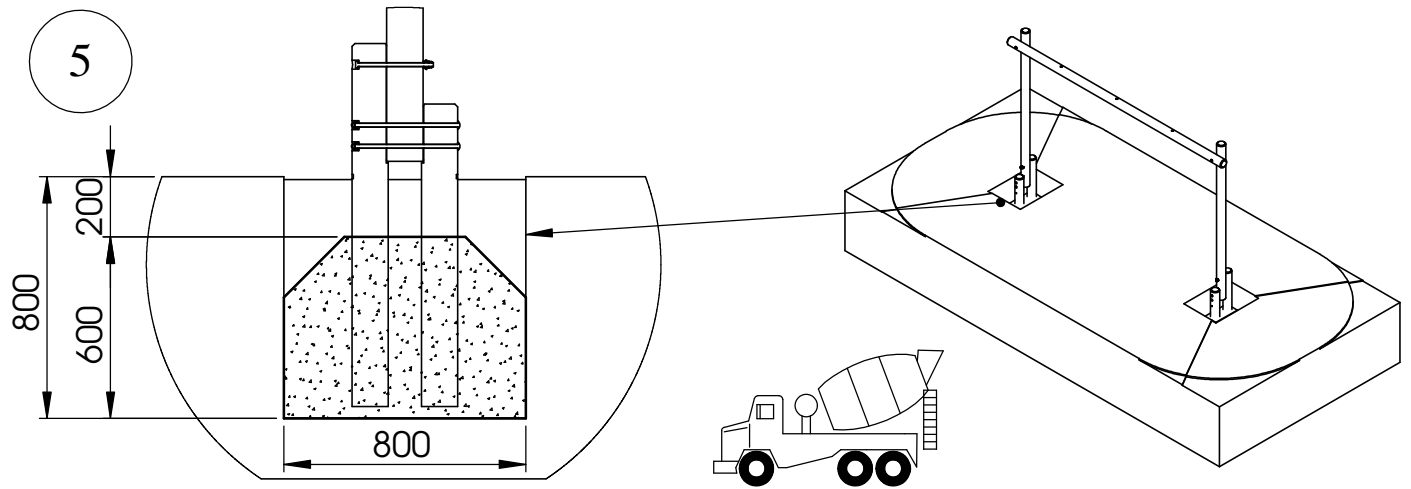

8

Bij droog weer moeten alle bouten en schroeven opnieuw aangespannen worden.
 Par temps sec il faut resserrer régulièrement toute la visserie.
 By dry and warm weather check the tightness of all bolts and screws.
 Bei trockenem Wetter müssen alle Schrauben und Bolzen aufs neue angespannt werden.
 Para el tiempo seco, se necesita cerrar o ajustar los tornillos y tuercas.
 Con tempo asciutto, tutti i bulloni e le viti devono essere avvitate nuovamente.