

FIRST DEGREE FITNESS  
*Fluid* INNOVATION

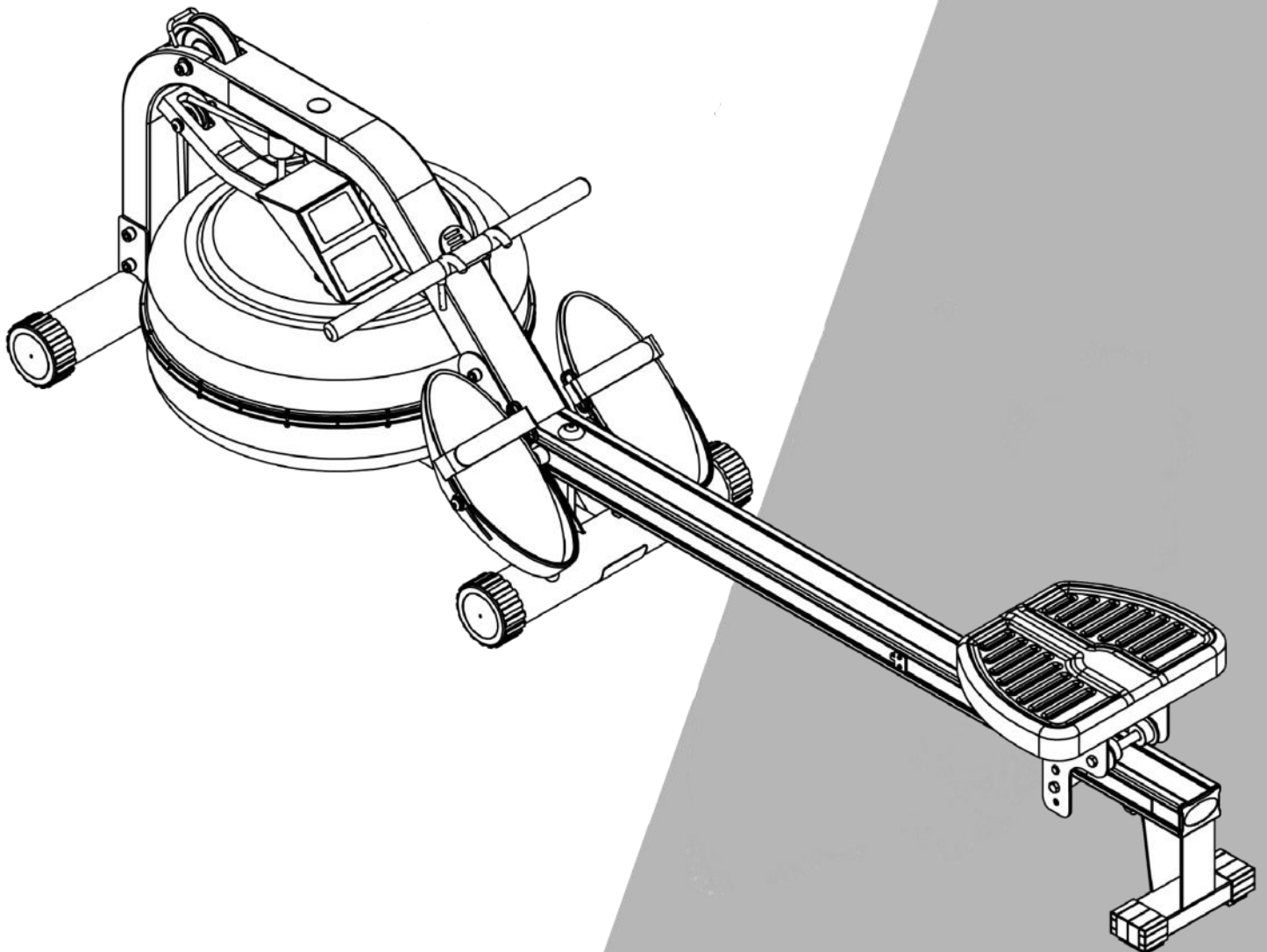

# » USER GUIDE

NEPTUNE AR  
TITAN AR



REGISTER YOUR PRODUCT AT [WWW.FIRSTDEGREEFITNESS.COM/SUPPORT](http://WWW.FIRSTDEGREEFITNESS.COM/SUPPORT)

# » Introduction

---

Congratulations on your purchase of Rower.

FIRST DEGREE FITNESS is proud to present the Rower as a home use product featuring patented Adjustable Fluid Resistance.

Follow all instructions carefully for correct assembly, tank filling, water treatment, service and safety.

Access to our world-wide distributor and service network is available at [www.firstdegreefitness.com](http://www.firstdegreefitness.com)

Check contents of Box 1 and Box 2 to assure all parts are present and correct prior to assembly.

## Training with the Rower

1. As with any piece of fitness equipment, consult a physician before beginning your Rower exercise program.
2. Follow instructions provided in this manual for correct foot position and basic rowing techniques.
3. For more detailed rowing techniques, please refer to our international website at [www.firstdegreefitness.com](http://www.firstdegreefitness.com)



1. Keep hands and fingers away from moving parts, as indicated in this manual.
2. The Rower can stand vertically for storage. Make sure a secure location is chosen, such as the corner of a room or against a wall on an even, secure surface.

**Note:** If the storage area is not level, an additional fixture is required (sold separately) to keep the Rower stable with vertical storage position.

# » Contents

---

|                                      |    |
|--------------------------------------|----|
| Safety .....                         | 4  |
| Assembly .....                       | 6  |
| Fluid Rower Box 1 & 2 Contents ..... | 7  |
| Assembly Instructions.....           | 8  |
| Operation Instructions.....          | 12 |
| Computer Operation .....             | 15 |
| Detaching the Rower Belt.....        | 16 |
| Reattaching the Rower Belt.....      | 17 |
| Removing the Bungee Shock Cord ..... | 18 |
| Maintenance .....                    | 19 |
| Troubleshooting.....                 | 20 |
| Optional Fixture Installation .....  | 21 |
| International Warranty.....          | 22 |

## Safety Information

- Before using this product, it is essential to read this ENTIRE operation manual and ALL instructions. The Rower is intended for use solely in the manner described in this manual.
- UNDERSTANDING EACH AND EVERY WARNING TO THE FULLEST IS IMPORTANT
- As with any piece of fitness equipment, consult a physician before beginning your Rower exercise program.
- Please be aware that any fitness regiment, before being undertaken, is best preceded by a physical checkup from a certified physician.
- Injuries to health may result from incorrect or excessive training.
-  **WARNING** Heart rate monitoring systems may be inaccurate. Over exercise may result in serious injury or death. If you feel faint, stop exercising immediately.
- Stop the machine immediately if any signs of excessive wearing is present on the belts, pulleys and bungee cords. Do not use unit until said parts are repaired or replaced.
- Do not allow children unattended access to the machine.
- The Rower can stand vertically for storage. When doing so, please follow the instructions given in the manual.
- Please keep hands away from moving parts, as indicated by the warning label on the mainframe of your machine.
- If any of the adjustment devices are left projecting, they could interfere with the user's movement.
- Do not store in freezing conditions with water in the tank as it can expand and crack the components.

## Installation

- Place on a stable, flat surface in a horizontal position during use for maximum stability.
- Check all belts, pulleys and bungee cords regularly for signs of wear, and replace if needed.
- Check regularly and follow all instructions for maintenance as specified in this manual.
- Replace immediately any defective parts and do not operate unit until all repairs are complete.





## Proper Usage

- Do not use any equipment in any way other than designed or intended by the manufacturer. It is imperative that FIRST DEGREE FITNESS equipment is used properly to avoid injury.
- Injuries may result if exercising improperly or excessively. It is recommended that all individuals consult a physician prior to commencing an exercise program. If at any time during exercise you feel faint, dizzy or experience pain, STOP EXERCISING and consult your physician.
- Keep body parts (hands, feet, hair, etc.), clothing and jewelry away from moving parts to avoid injury.
- Follow instructions provided in this manual for correct foot position and basic rowing techniques.
- For more detailed rowing techniques, please refer to our International website [www.firstdegreefitness.com](http://www.firstdegreefitness.com)

## Inspection

- DO NOT use or permit use of any equipment that is damaged and/or has worn or broken parts. For all FIRST DEGREE FITNESS equipment use only replacement parts supplied by FIRST DEGREE FITNESS.
- Cables and belts pose an extreme liability if used when frayed. Always replace any cable or belt at first sign of wear (consult FIRST DEGREE FITNESS if uncertain).
- EQUIPMENT MAINTENANCE - Preventative maintenance is the key to smooth operating equipment as well as to keep your liability to a minimum. Equipment needs to be inspected at regular intervals.
- Ensure that any person(s) making adjustments or performing maintenance or repair of any kind is qualified to do so.
- DO NOT ATTEMPT TO USE OR REPAIR ANY ACCESSORY APPROVED FOR USE WITH THE FIRST DEGREE FITNESS EQUIPMENT WHICH APPEARS TO BE DAMAGED OR WORN.
- Check all belts, pulleys and bungee cords regularly for signs of wear, and replace if needed.
- Check regularly and follow all instructions for maintenance as specified in this manual.
- Replace immediately any defective parts and do not operate unit until all repairs are complete.

## Operating Warnings

- Keep children away from the equipment. Parents or others supervising children must provide close supervision of children if the equipment is used in the presence of children.
- Do not allow users to wear loose fitting clothing or jewelry while using equipment. It is also recommended to have users secure long hair back and up to avoid contact with moving parts.
- All bystanders must stay clear of all users, moving parts and attached accessories and components while machine is in operation.
-  **WARNING** Do not insert fingers into tank!
-  **CAUTION** After rowing, let the rower sit for at least 3 minutes before standing it up for storage.
-  **CAUTION** Do not fill past the calibration mark as indicated on the tank level sticker or water spillage can occur.
-  **WARNING** Never operate this rower without feet properly secured in Footstraps, or without the sliding portion of the Slider Footplate locked into position!

# » Assembly

## Product Specifications

**Product Class:** HC

**Braking System:** Speed Independent

**Product Net Weight:** 27.6kg (60.85lbs)

**Product Gross Weight:** 34kg (74.96lbs)

**Minimum Safe Operating Surface Area:** 319cm (125.59") x 172cm (67.71")

**Dimensions:** 1990mm (78.35") Length x 520mm (20.47") Width x 520mm (20.47") Height

**Maximum User Weight:** 150kg (330lbs)

**Compact Footprint:** 1990mm x 520mm or upright 520mm x 520mm

## Product Highlights

Durable belt drive  
with active recoil  
system

Patented twin tank design

Ergonomic handle design

Footplate

Seat Frame

Transport  
Wheels

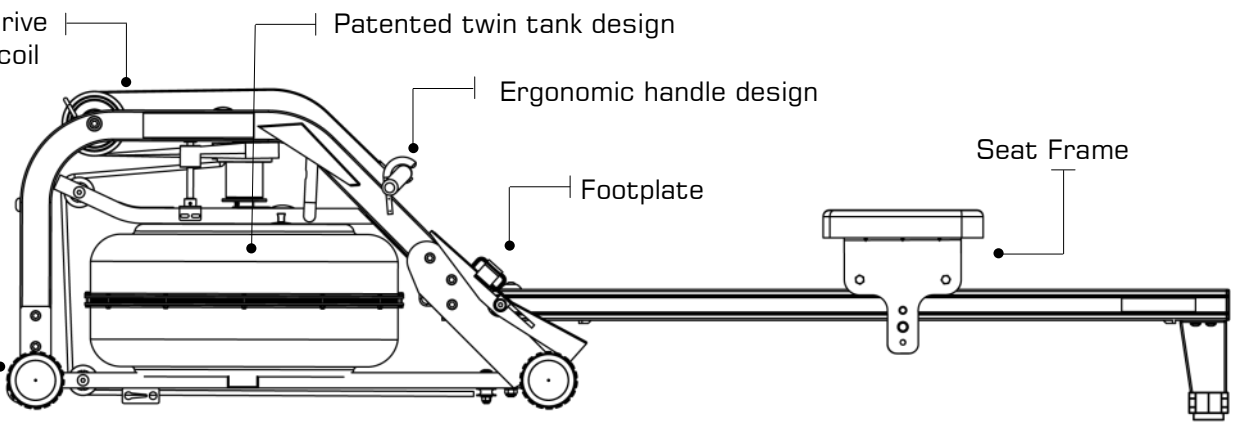

The live area shall be not less than 23.62" (60cm) greater than the training area in the directions from which the equipment is accessed. The live area must also include the area for emergency dismount.

## Live area and Training area

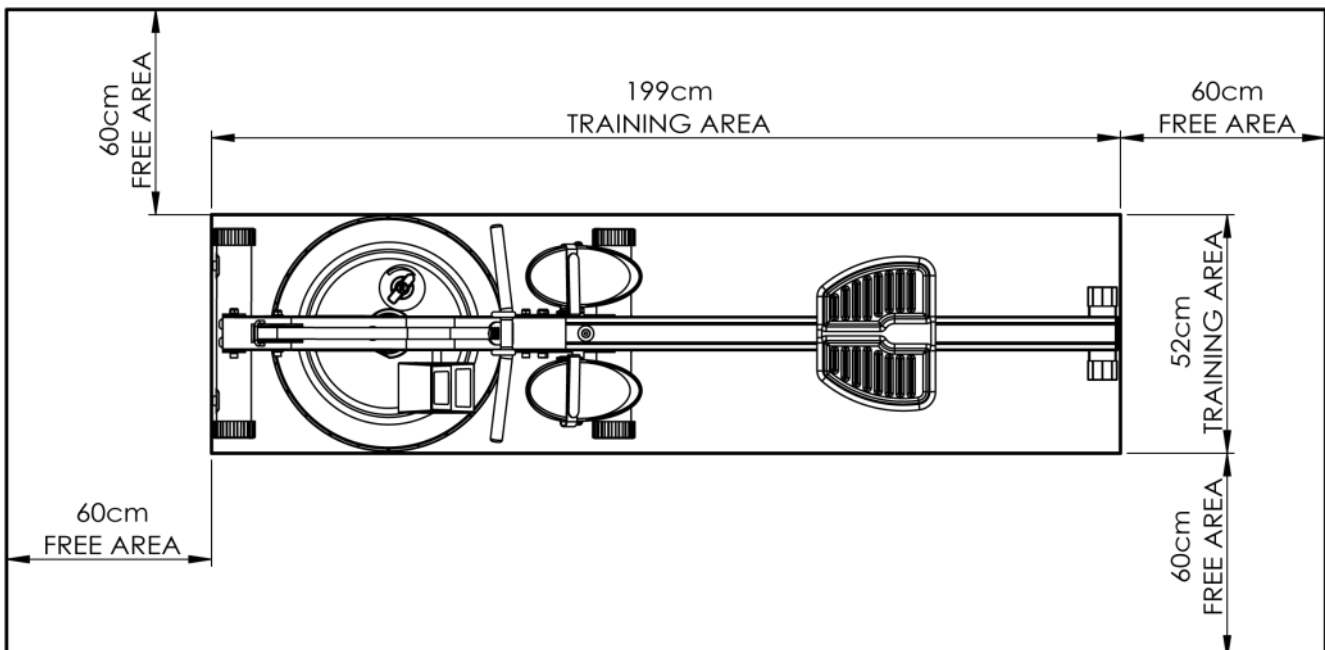

Note: Rower is not suitable for therapeutic purposes.

# Fluid Rower Box 1 & 2 Contents

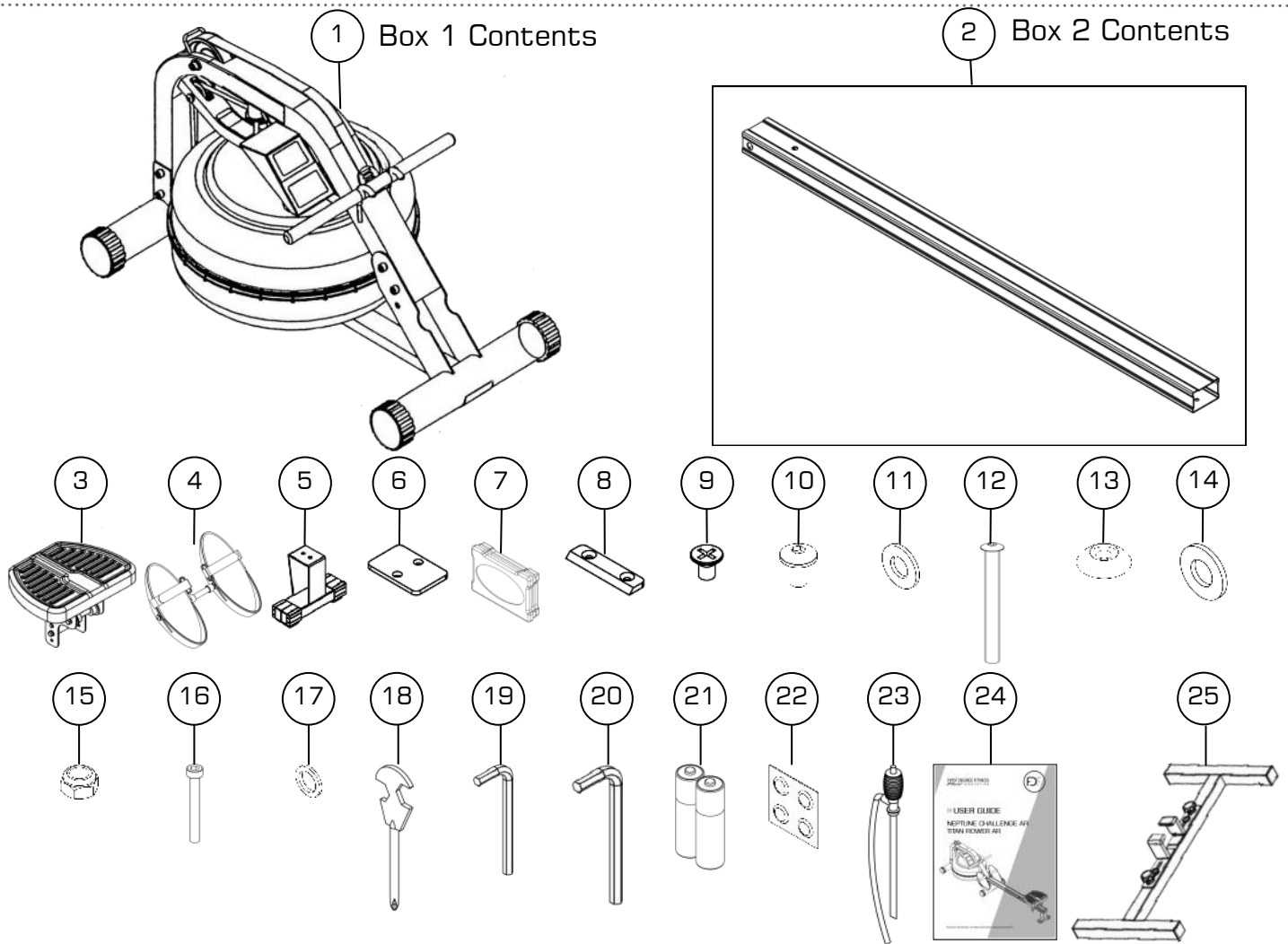

| Item | Qty | Description                  | Item                                     | Qty | Description                   |
|------|-----|------------------------------|--|-----|-------------------------------|
| 1    | 1   | Main Frame                   | 14                                       | 1   | M10 Washer                    |
| 2    | 1   | Seat Rail (boxed separately) | 15                                       | 2   | M10 Nylock Nut                |
| 3    | 1   | Rower Seat                   | 16                                       | 1   | M10x95mm Bolt                 |
| 4    | 1   | Footplate Assembly           | 17                                       | 2   | M10 Springs Washer            |
| 5    | 1   | Rear Leg                     | 18                                       | 1   | Multi-Tool                    |
| 6    | 1   | Internal Mounting Plate      | 19                                       | 1   | 6mm Allen Key                 |
| 7    | 1   | 75x50 Rubber End Cap         | 20                                       | 1   | 8mm Allen Key                 |
| 8    | 1   | Rubber BumpStop—Seat Rail    | 21                                       | 2   | AA Duracell Battery           |
| 9    | 2   | M6x10mm Bolt                 | 22                                       | 4   | Water Treatment Tablet        |
| 10   | 2   | M8x15mm Bolt                 | 23                                       | 1   | Siphon                        |
| 11   | 2   | M8 Washer                    | 24                                       | 1   | User Guide                    |
| 12   | 1   | M10x180mm Bolt               | <b>Optional Equipment (Not Included)</b> |     |                               |
| 13   | 1   | M10 Plastic Dome Washer      | 25                                       | 1   | Optional Stand (not included) |

# » Assembly Instructions

## STEP 1 Installing the Seat and Rear Leg to Seat Rail

### REQUIRED

Seat Rail (2)

Rower Seat (3)

### ! WARNING

Installing the Seat incorrectly will result in lack of data pickup during rowing.

- a) Install Rower Seat[3] onto Seat Rail[2], with widest part of seat rearward.

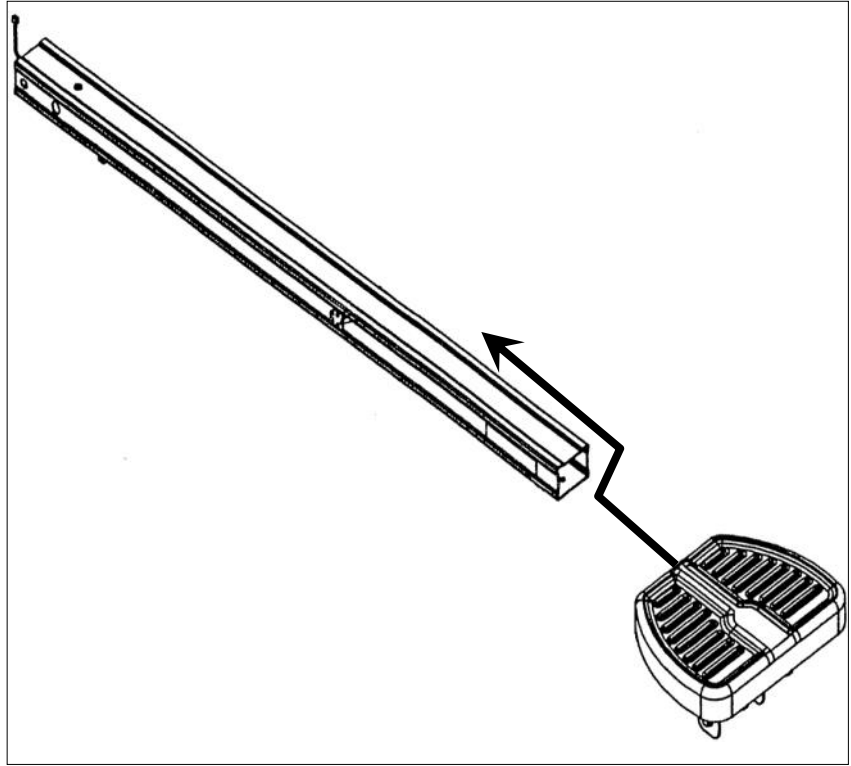

## STEP 2

### REQUIRED

Rubber Bumpstop (8)

2 x M6x10mm Bolts (9)

- a) Turn Seat Rail over, and install the Rear Rubber Bumpstop[8] using 2x M6x10mm Bolts[9] with beveled edge facing forward.

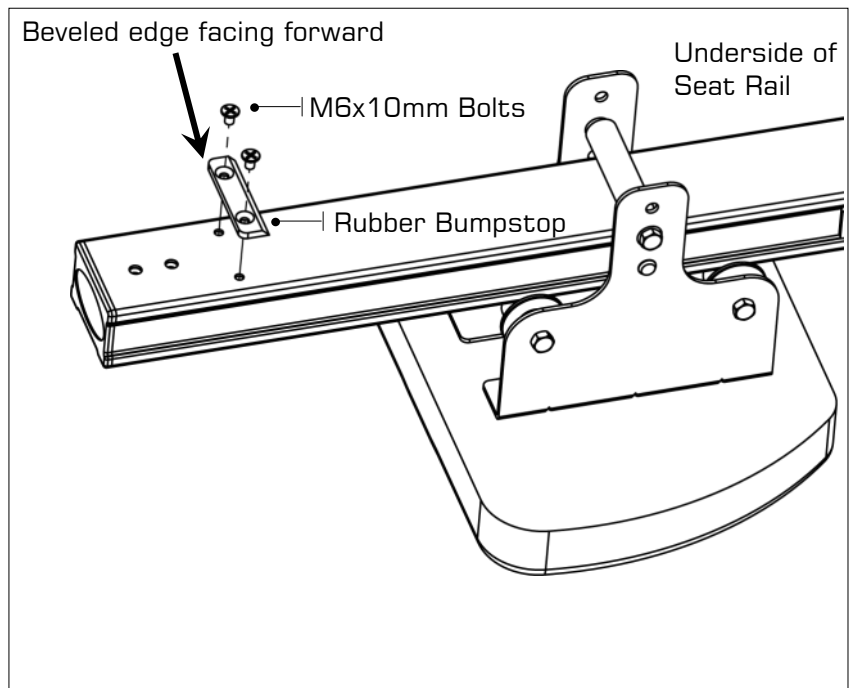



# Assembly Instructions

## STEP 3 Installing the Rear Leg

### REQUIRED

Rear Leg (5)

Internal Mounting Plate (6)

Rubber End Cap (7)

2 x M8x15mm Bolts (10)

2 x M8 Washers (11)

- a) Using the 2x M8x15mm Bolts[10], 2x M8 Washers[11], Internal Mounting Plate[6] and Rear Leg[5], install as shown. Once Rear Leg is tightened, install the Rear Rubber End Cap[7].

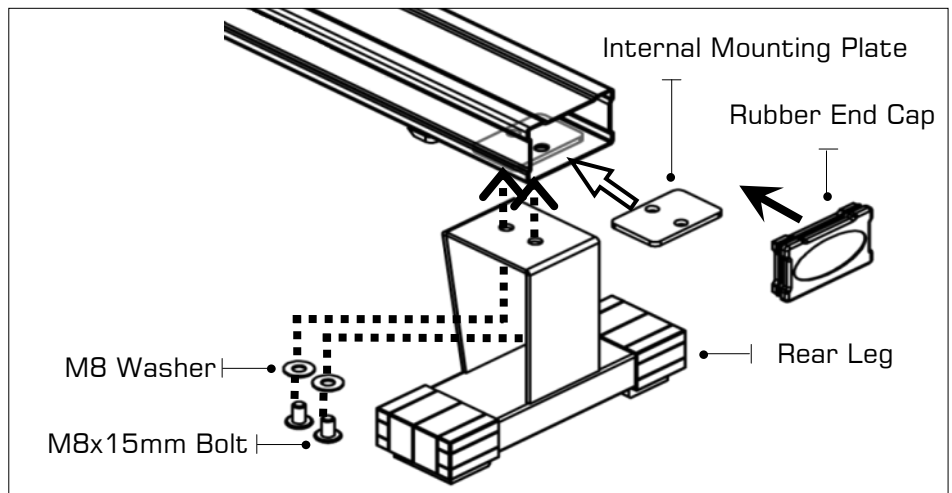

## STEP 4 Installing the Seat Rail to Mainframe

### REQUIRED

M10 Nylock Nut (15)

M10x95mm Bolt (16)

2 x M10 Washer (17)

- a) Install the Seat Rail onto the Mainframe. Attach Sensor Lead from Seat Rail to the Mainframe, then align the front Seat Rail holes with Mainframe and install, using M10x95mm Bolt[16], 2x M10 Washer[17] and M10 Nylock Nut[15].

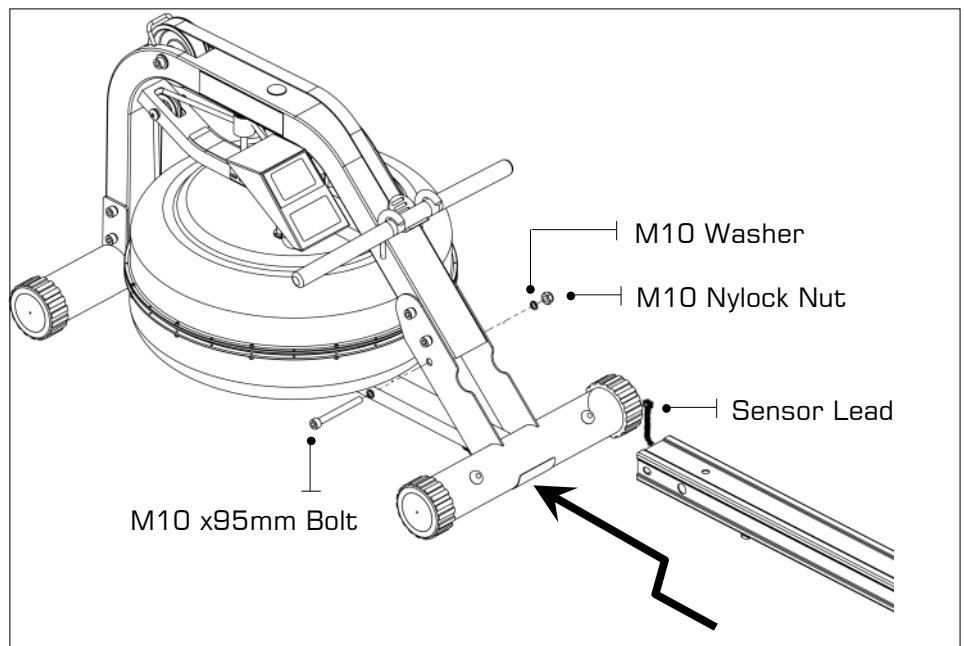

# » Assembly Instructions

## STEP 5 Installing the Seat Rail to Mainframe

### REQUIRED

M10 x180mm Bolt (12)

Plastic Dome Cap (13)

M10 Washer (14)

M10 Nylock Nut (15)

### ! WARNING

Do not tighten the Vertical Frame Tensioning Bolt. See the "Fine Tuning Your Rower" page for details once assembly is complete

- a) Install the **M10x180mm Bolt**[12] with the **Plastic Dome Cap**[13] through the top of the Seat Rail and secure from underneath with **M10 Washer**[14] and **Nylock Nut**[15].

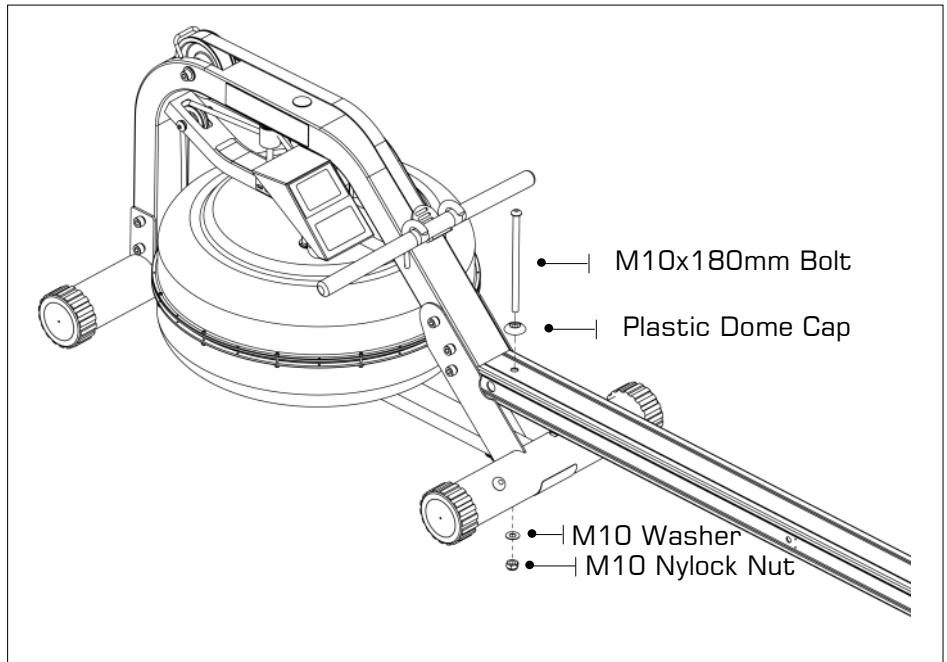

## STEP 6 Installing the Footplate

### REQUIRED

Footplate (4)

### ! CAUTION

**Tip:** When mounting the Footplate assembly onto the rower, it is only necessary to remove one side, and leave the other intact as shown here.

**Note:** 2 Allen keys of the same size are provided for this portion of the assembly.

- a) Install the **Footplate**[4] onto the Rower. Footplate assembly left side. For ease of assembly, leave the left side of the Footplate and Seat Rail Spacer in place as shown.

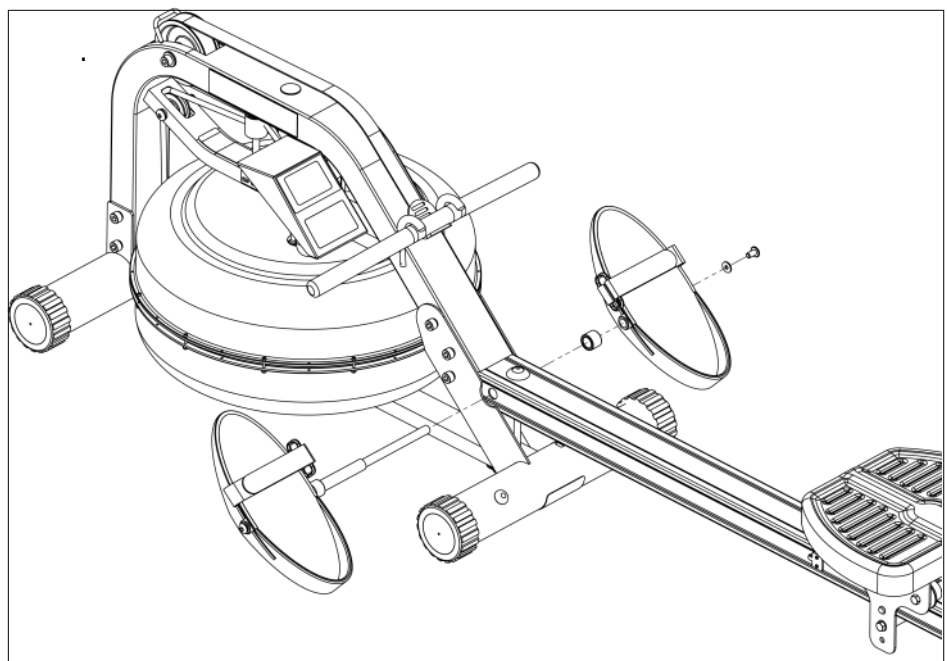

## » Assembly Instructions

### STEP 7 Fine Tuning the Rower

The Vertical Seat Rail Tensioning Bolt is designed to hold the mid leg 3-5mm off the ground when the Fluid Rower is unweighted, and just slightly touch the ground during a rowing stroke.

Tighten the assembly until the Mid Leg begins to lift off of the ground as shown below.

**Note:** If excessive head shaking/hopping of the tank occurs during rowing, this indicates the Vertical Seat Rail Tensioning Bolt being out of adjustment.

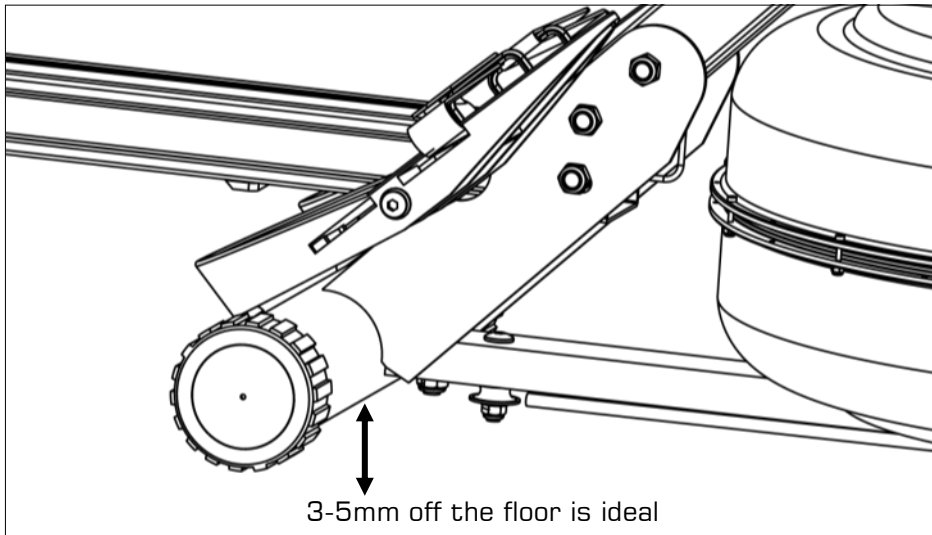

Close up view of the Vertical Seat Rail Tensioning Bolt M10 Nylock location.

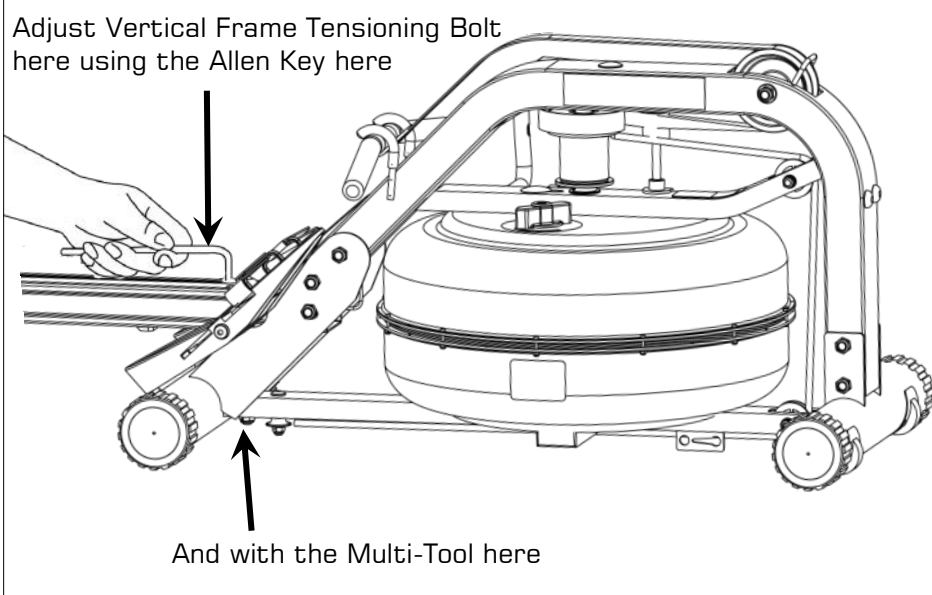

Tension the Vertical Seat Rail Tensioning Bolt as shown here.

# »» Operation Instructions

## »» Adjustable Resistance (AR) Tank

The Adjustable Resistance (AR) Tank, developed and patented by FIRST DEGREE FITNESS, offers a true multi-level experience. Water is moved between the "storage" and "active" chambers of the AR Tank. Your new Rowing Ergometer can adapt - at the turn of a dial - to the resistance preferred by each user in the home environment.

### Getting Started

To achieve minimum resistance, select "MIN" on the tank adjuster. **It takes 10 strokes to fill the central (storage) tank, leaving a minimal amount of water in the outer (active) tank. This process is always required if minimum resistance is desired.** Row hard at a steady pace (20 to 25 strokes per minute [SPM]) and put some effort into the stroke, ensuring that good form is maintained. You can make adjustments to the resistance level while you row. Your Rowing Ergometer will adapt almost instantly to increases in resistance but will take up to 10 strokes to reduce the effort required, as the central (storage) tank fills up.

### Developing Your Routine

Once you have found a level that gives you the exercise required, changes can be made to SPM and to stroke intensity to further vary your energy input. Interval training is used by most Rowers, where a period of low intensity is combined with short intervals of high intensity. Your FDF Rowing Ergometer allows for changes 'on the fly', to achieve multi-level resistance profiles during a single workout. For more information on exercise routines, please visit our website at [www.firstdegreefitness.com](http://www.firstdegreefitness.com)

## »» Tank Filling and Water Treatment Procedures

### REQUIRED

Siphon (23)

### ! CAUTION

Resistance adjuster must be set to 'Max' to allow for accurate filling capacity.

### ! WARNING

Do not overfill the tank beyond the maximum indicated level of 17 liters. Refer to the tank level decal on the lower side of the tank.

- Remove rubber fill plug from the top of the tank.
- Place a large bucket of water next to the rower. Position the **Siphon[23]** with rigid hose in the bucket, and flexible hose in the tank.

**Note:** Make sure small breather valve on siphon is closed before filling.

- Squeeze siphon to begin filling. **Important:** Do not overfill tank
- When full, open the valve on the top of the siphon to allow excess water to escape.
- Once filling is completed follow the water treatment schedule below, then replace the tank plug.

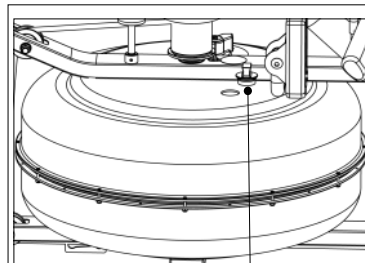
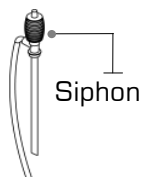

Tank Plug

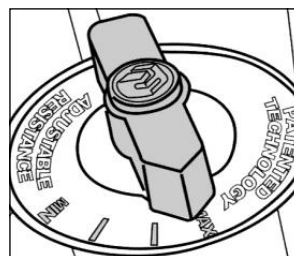

**MIN:** This setting keeps a portion of the water in reserve creating light resistance

**MAX:** This setting allows the maximum amount of water to reach the flywheel for heaviest resistance

### INITIAL WATER TREATMENT

Add 1 x Water Treatment Tablet per full tank. **DO NOT, UNDER ANY CIRCUMSTANCE, USE A WATER TREATMENT TABLET OTHER THAN THOSE SUPPLIED WITH YOUR UNIT.** Your unit purchase includes 4 x Water Treatment Tablets, which is sufficient for several years of use. To purchase additional chlorine tabs, please consult your nearest regional dealer/distributor or check our website at [www.firstdegreefitness.com](http://www.firstdegreefitness.com)

## »» Operation Instructions

### »» Removing/Changing Tank Water

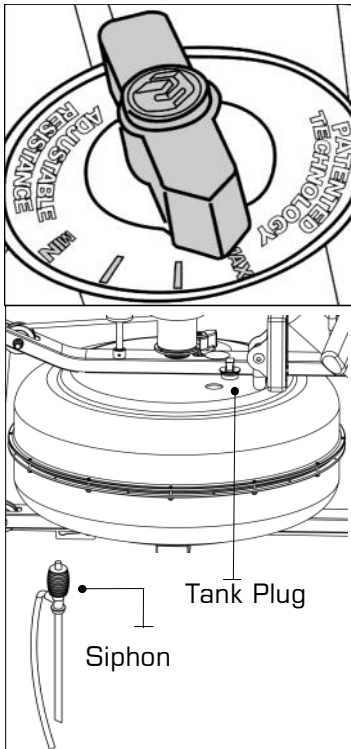

Row a minimum of ten complete strokes before commencing tank draining. Remove tank plug, insert rigid end of siphon into tank and begin draining.

- Set Adjuster handle to "MIN"
- Row at least ten strokes to fill the storage reservoir as completely as possible.
- Remove Tank Plug.
- Insert rigid end of siphon into the tank, and flexible hose into a large bucket.
- Drain tank (approx. 40% of water will remain) and then refill following directions for Tank filling as described in the Tank Filling section of this manual.

**Note:**

- ⊙ The valve on top of the siphon must be closed to allow proper drainage.
- ⊙ Water treatment will preclude the need to change tank water if the treatment schedule is maintained. Additional Water Treatment Tablet is required only when discoloration appears in the water.
- ⊙ Exposure to full sunlight reduces the life of the Water Treatment Tablets. Storing the rower away from direct sunlight will extend the time between water treatments.
- ⊙ Approximately 40% of tank water will remain. It is not possible to completely drain the A/R tank without disassembly.

### »» Long Term Water Treatment and Basic Operation

**Do not use any water treatment other than the tablets supplied with this unit.** For replacement tablets, contact your local FIRST DEGREE FITNESS distributor. Water treatment schedules for the FLUID ROWER will vary according to the fluid tanks exposure to sunlight, but expect 8-12 months near a bright, sunlit window and 2 years or more for a darker location. At the point of finding the water slightly cloudy, add a Water Treatment Tablet.

**⚠ CAUTION**

It is strongly recommended that a drop cloth be used under the fluid tank whenever the tank plug is opened for water treatment.

# »» Operation Instructions

## »» Start Rowing

There are six phases to completing a rowing stroke

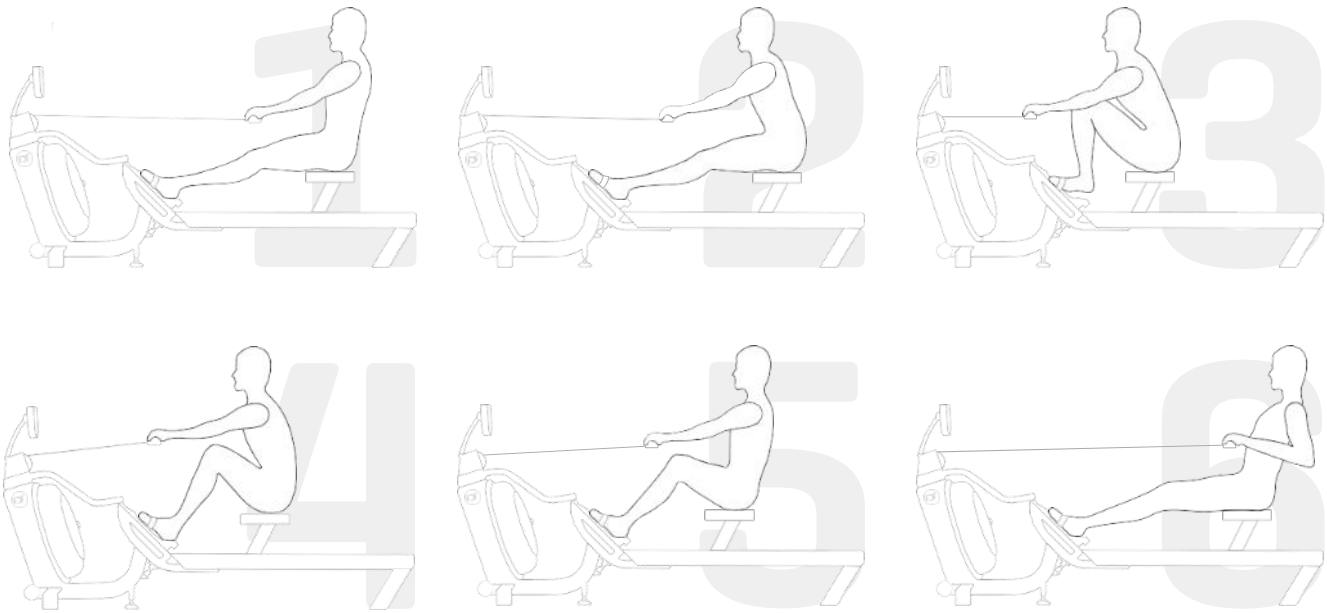

1. Sit with straight legs and back, leaning forward slightly at the hips with arms out straight and hands level with the lower ribs. Swing back.
2. Legs and back straight, leaning slightly forward from the hips, arms out in front. Lean and slide forward.

**Note:** Hands should now be around your knees, keeping legs straight.

3. Legs come forward, aiming to get the shins vertical. Back is still straight, and posture leaning slightly forward with arms still out front. Now drive hard, this is the CATCH.
4. Knees partially straightened so seat is now at mid-point of travel, back and arms still straight. Maintain the stroke.
5. Knees are nearly straight, back is still straight but now leaning slightly back from the hips. Arms straight. Now squeeze through.
6. Legs now fully extended. Back straight and leaning slightly back, now pull with the arms so they are close to the chest, forearms horizontal and elbows close in to the rib cage. This is the FINISH.

For more information on correct rowing technique and workout tips visit our website [www.firstdegreefitness.com/indoor-rowing-technique](http://www.firstdegreefitness.com/indoor-rowing-technique)



**CAUTION** Always consult a doctor before beginning an exercise program. Stop immediately if you feel faint or dizzy.

# » Computer Operation

## Options:

Install the batteries, and the LCD panel will display with an audible buzz.

**Mode:** Allows access to various settings:

**Set:** Press when digits are flashing to set values upward. Can be applied for all settings with the exception of "Total Count" and "SPM". Once values are set, press "Enter" to move into the following mode.

**Reset:** Press this key to reset values.

**Note:** Total count can only be reset by taking out and reinstalling batteries.

**Enter:** Press to set values. Numbers will flash. Press "Set" to fix settings.

Once values are decided, the computer will scroll through the various settings every six seconds. The settings can be fixed into a set value (SPM for example) by pressing the "Mode" button. Values such as time will accumulate toward zero and an audible alarm will sound once zero is reached. Press any key to stop the alarm.

The Computer will enter sleep mode if not used for over 4minutes, 30 seconds.

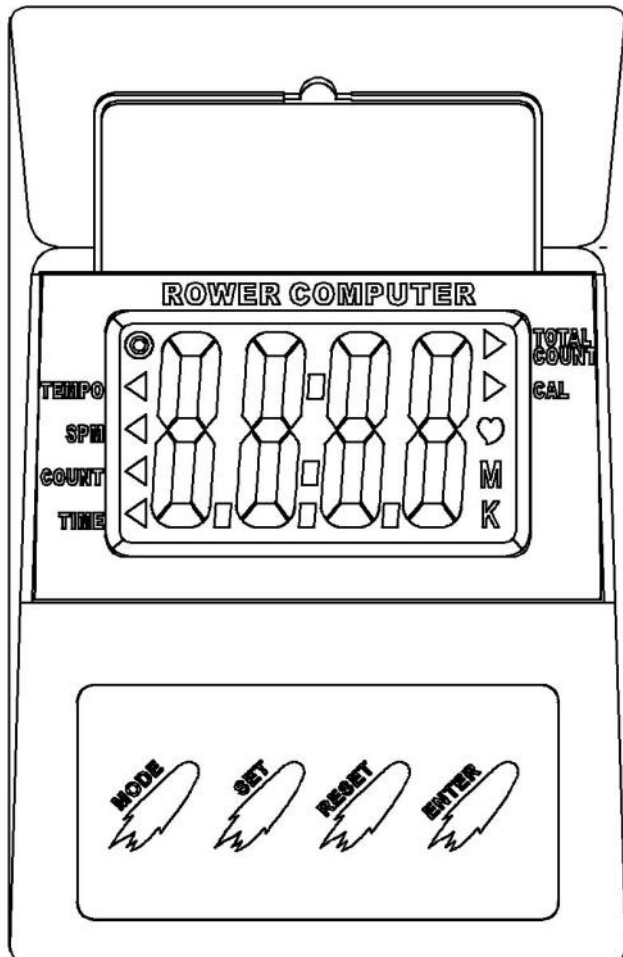

## Computer Instructions:

**Time:** Working range from 0:00-99:59

**Count:** Working Range from 0-9999

**SPM:** 15SPM-3000.

**Calories:** 0-9999

**Total Count:** 0-9999

**Note:** Computer must be turned off and restarted to reset total count.

**Tempo:** Working range from 0-180 beeps per minute.

## » Detaching the Rower Belt

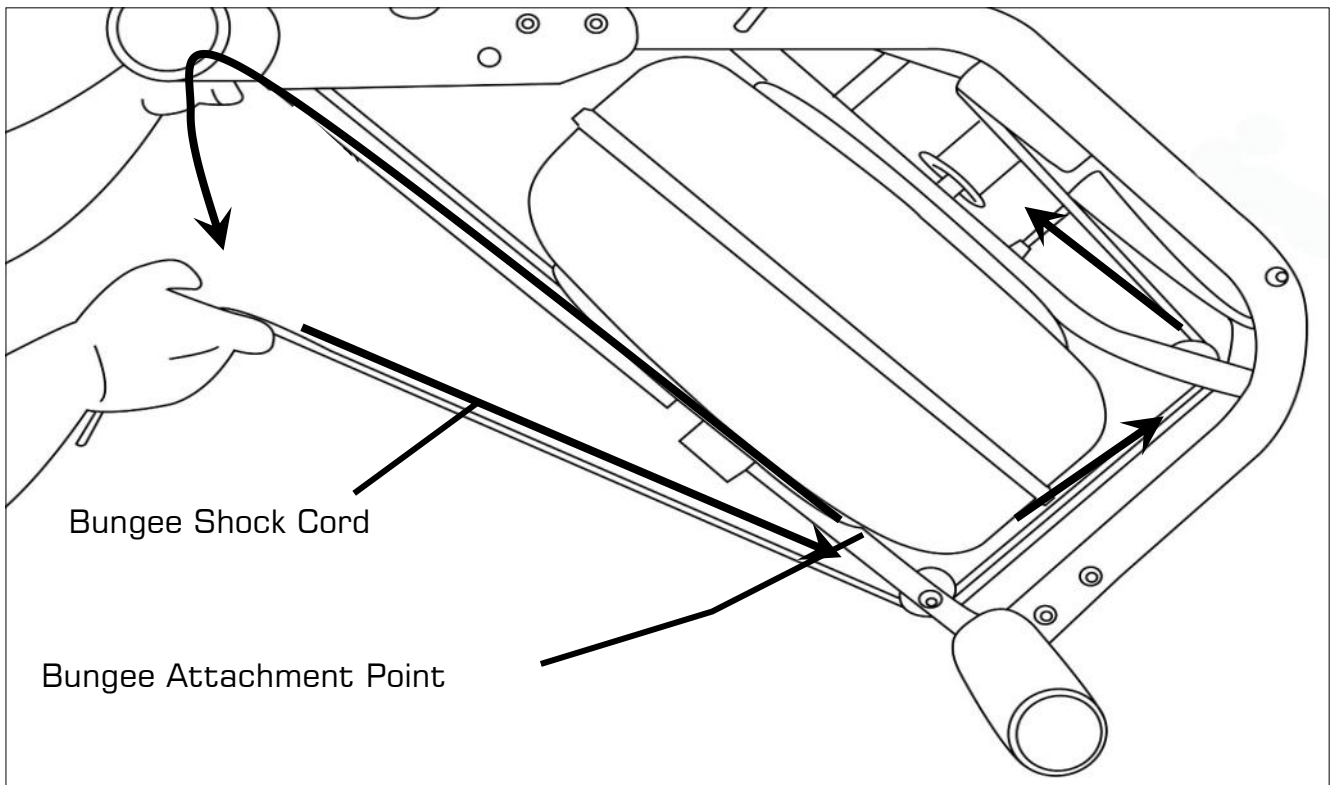

1. To detach belt, simply pull beyond the range of the normal rowing stroke until the belt detaches from the Belt Bungee Pulley.

**Tip:** You'll hear the Velcro separating just before the belt detaches.

2. Cut plastic tie holding bungee at the Bungee Attachment Point, pull the Cord through all three pulleys and leave excess on top of the tank for now.



# » Reattaching the Rower Belt

## STEP 1

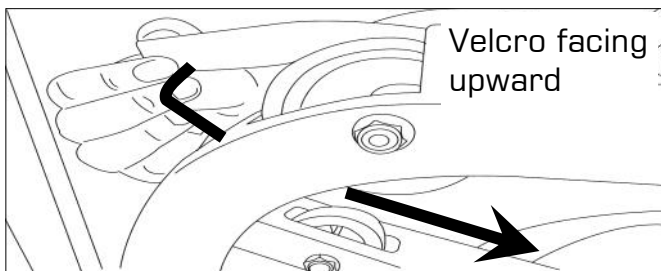

Begin reattaching the Rower Belt by threading around the Rower Belt Pulley with the Velcro side facing upward as illustrated.

## STEP 2

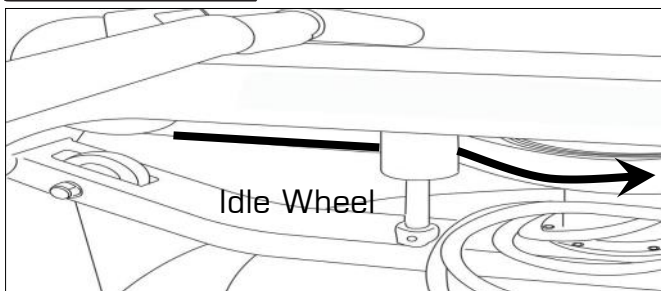

Next, thread the Belt around the Idle Wheel as shown. Once around the Idle Wheel, attach the Rower Belt to the Belt/Bungee Pulley. There is an obvious "lip" at the attachment point.

## STEP 3

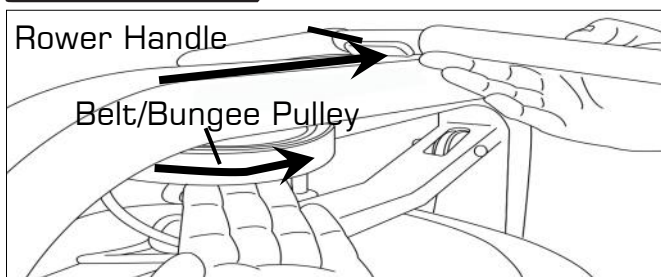

Wind the Rower Belt onto the Belt/Bungee Pulley until the Rower Handle is as it's furthest forward position.

## STEP 4

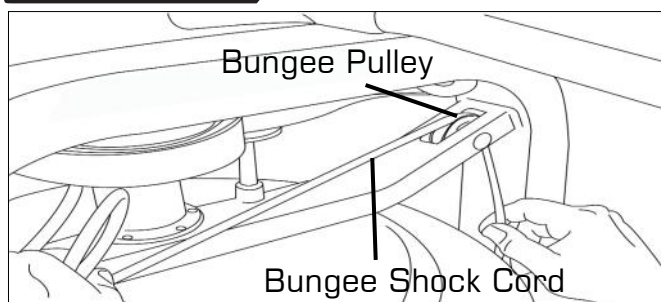

Rethread the Bungee Shock Cord (on opposite side of the Idle Wheel) back through the Bungee Pulleys and tie off at the Attachment Point.

## STEP 5

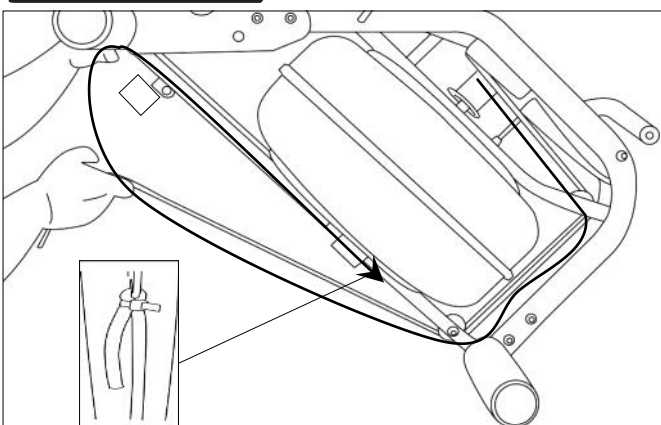

If Bungee Shock Cords previous tension seemed correct (a good way to judge is if the Rower Handle can make it to the furthest point forward on the top of the Mainframe under bungee tension alone) then simply tie off at previous position. If the return is too slack, experiment by tightening the tension in small increments and testing until the correct tension is achieved. If the Rower Handle cannot reach the end of the seat rail during a rowing stroke, then the Bungee Shock Cord is over-tensioned.

### Hint

If Bungee Shock Cords previous tension seemed correct (a good way to judge is if the Rower Handle can make it to the furthest point forward on the top of the Mainframe under bungee tension alone) then simply tie off at previous position. If the return is too slack, experiment by tightening the tension in small increments and testing until the correct tension is achieved. If the Rower Handle cannot reach the end of the seat rail during a rowing stroke, then the Bungee Shock Cord is over-tensioned.

## » Removing the Bungee Shock Cord

### STEP 1

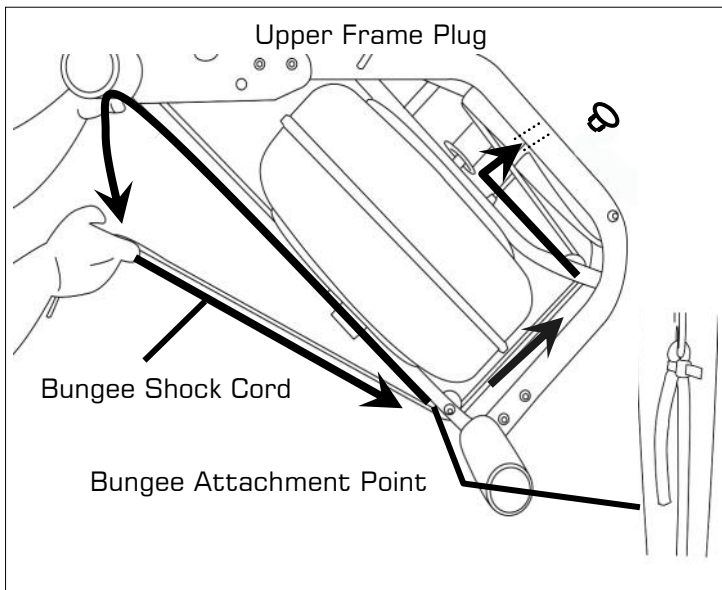

Move the Rowing Handle to its farthest forward point on the Mainframe, then cut the plastic end tie and follow the drawing above for bungee removal.

Next, remove the Upper Frame Plug to allow the Bungee Shock Cord to be threaded through the top of the frame. Note: You will need to rotate the Belt/Bungee Pulley to align the holes properly. Should the belt drop off of during the bungee change, please refer to the previous pages for "Attaching/Reattaching the Rower Belt".

### STEP 2

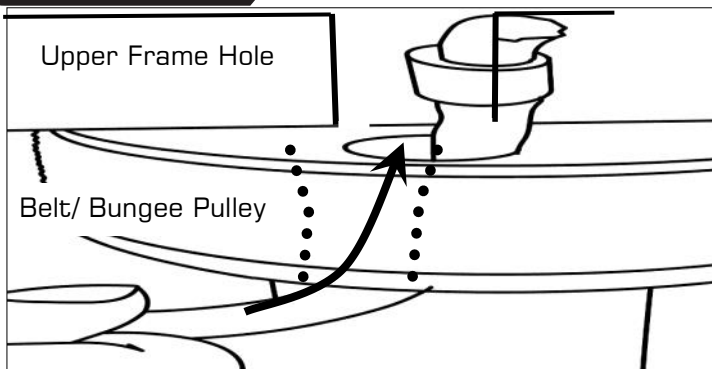

Once Bungee Cord and Upper Frame Hole are aligned, push the Bungee Cord up and through the frame as shown

## » Replacing the Bungee Shock Cord

Reinstall the Shock Cord through the Upper Frame, along the opposite side of Idle Wheel, through the Mid Frame and Lower Bungee Pulleys and then tie off with plastic tie wrap to correct tension. Replace Frame Plug.

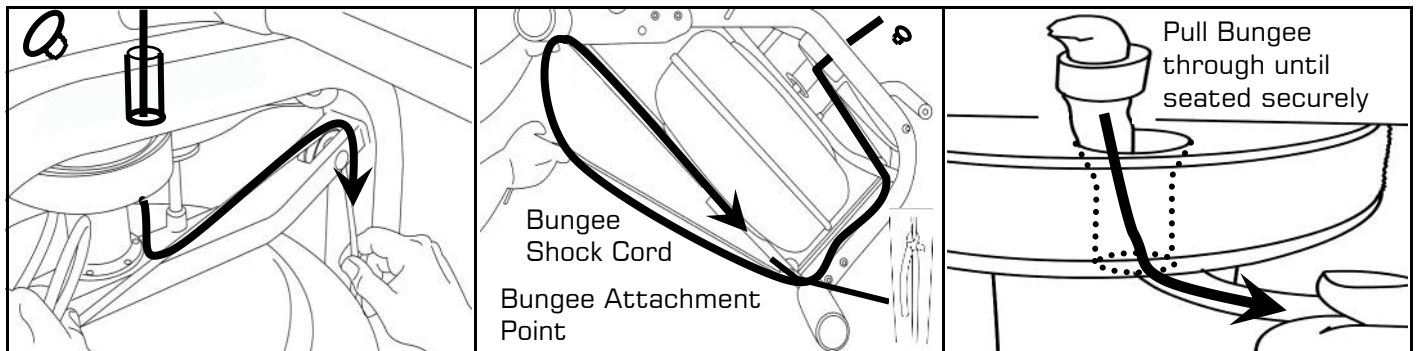

**Tip:** Correct bungee tension is achieved when enough recoil is present for the Rowing Handle to easily reach the front of the Fluid Rower Pulley Belt Bracket at the far front of the frame. If the Rowing Handle will not reach rearward to the end of the Seat Rail, the Bungee Cord is over-tightened and will require adjustment.

## » Maintenance

All preventive maintenance activities must be performed on a regular basis. Performing routine preventive maintenance actions can aid in providing safe, trouble-free operation of all FIRST DEGREE FITNESS equipment.

FIRST DEGREE FITNESS is not responsible for performing regular inspection and maintenance actions for your machines. Instruct all personnel in equipment inspection and maintenance actions and also in accident reporting and recording.

FIRST DEGREE FITNESS representatives are available to answer any questions that you may have.

| Item                     | Time Frame   | Instructions   | Notes |
|--------------------------|--|--|-------|
| Seat Wheels and Runners  | Weekly   | Wipe down Seat Wheels and Runners with lint free cloth.  |       |
| Frame                    | Weekly   | Wipe down Frame with lint free cloth.  |       |
| Tank and Water Treatment | 12 months to 2 years   | Follow instructions as specified in the "Water Treatment" section of this manual.  |       |
| Bungee Cord              | Check every hundred hours for correct tension and for signs of wear. | The Bungee Cord should last for many years. If a Bungee Cord change is required, please contact your local service representative or go online at <a href="http://www.firstdegreefitness.com">www.firstdegreefitness.com</a> for further details.                    |       |
| Rowing Belt              | Check every hundred hours for correct tension and for signs of wear. | The Rowing Belt should provide many years of trouble free use. If a Rowing Belt change is required, please contact your local service representative or go online at <a href="http://www.firstdegreefitness.com">www.firstdegreefitness.com</a> for further details. |       |

## » Troubleshooting

| Fault   | Probable Cause  | Solution  |
|---|---|---|
| Water changes color or becomes cloudy.                                    | Fluid Rower is in direct sunlight or has not had water treatment.   | Change Fluid Rower location to reduce direct exposure to sunlight. Add water treatment or change tank water as directed in the water treatment section of this manual. Consider using distilled water to refill tank. |
| Rower Belt slipping off belt/ bungee pulley.                              | Bungee not under enough tension.                                    | Tighten bungee cord following the instructions in "Replacing the Bungee/Shock Cord" section of this manual.   |
| Front of the Rower lifts slightly during vigorous rowing.                 | M10X150mm Vertical Seat Rail Tensioning Bolt is slightly too loose. | Tighten bolt 1/2 turn and row again. Tighten as needed until problem stops. Note: Over tightening this bolt can damage the seat rail. Only tighten bolt in small increments until fault is corrected.                 |
| The Rower Computer does not illuminate after battery installation.        | Batteries installed incorrectly or need replacing.                  | Reinstall batteries in correct position and try again. If the LCD screen fails to illuminate, try rotating the batteries slightly in the computer. If this fails, contact your local service center.                  |
| The Rower Computer screen illuminates, but does not register when rowing. | Loose or failed connection.   | Check that the computer lead is connected properly. If it is connected then contact your local service center.  |

# Optional Fixture Kit Installation

A fixture kit for upright storage can be purchased separately.

## STEP 1

Install the Z bracket onto the Storage Base.

Note: Do not tighten the Knob and the Bolt.

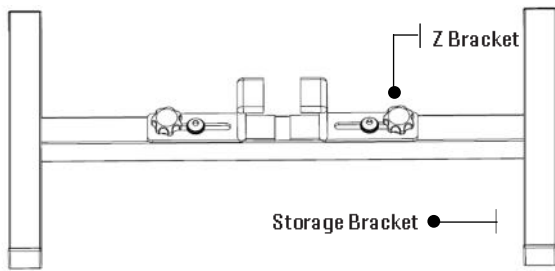

## STEP 2

Install the bracket onto the rower as shown.

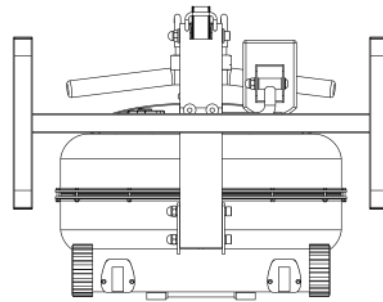

## STEP 3

Tighten the Z Bracket knob to fix to the rower.

Note: Ensure the Z bracket is secure before tightening.

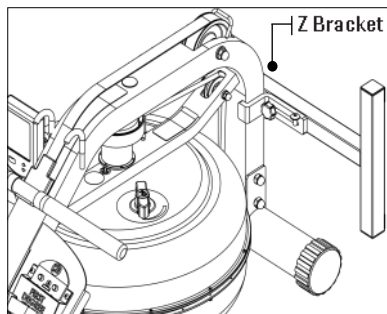
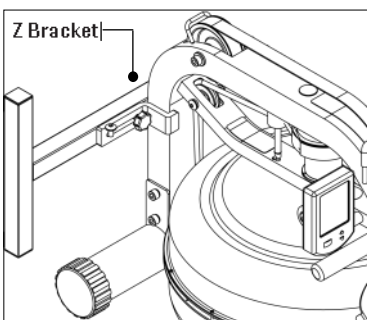

## STEP 4

Stand the rower up vertically with the main frame on the floor. Using the 8mm Allen Wrench tighten the Bolts.

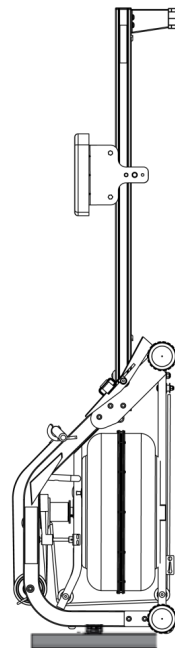

# » International Warranty

## HOME USE

FIRST DEGREE FITNESS Limited warrants that the **Neptune Challenge AR / Titan AR Rower (model NEPAR/TTNAR)**, purchased from an authorized agent and in its undamaged original packaging, is free from defects in materials and workmanship. FIRST DEGREE FITNESS Limited or its agent will, at their discretion, repair or replace parts that become defective within the warranty period, subject to the specific inclusions and exclusions below.

### **Metal Frame – 5 Year Limited Warranty**

FIRST DEGREE FITNESS will repair or replace the metal Main Frame of the Rower should it fail due to any defect in materials or workmanship within 5 years of the original purchase. Warranty does not apply to frame coating.

### **Polycarbonate Tank & Seals – 3 Year Limited Warranty**

FIRST DEGREE FITNESS will repair or replace the polycarbonate tank or seals should they fail due to any defect in materials or workmanship within 3 years of the original purchase.

### **Mechanical Components (of a non-wearing nature) – 2 Year Limited Warranty**

FIRST DEGREE FITNESS will repair or replace any mechanical component should it fail due to any defect in materials or workmanship within 2 years of the original purchase.

### **Specific Inclusions**

Aluminum Seat Rail  
Stainless Steel Impeller Assembly

### **All Other Components (of a wearing nature) – 1 Year Limited Warranty**

FIRST DEGREE FITNESS will repair or replace any component should it fail due to any defect in materials or workmanship within 1 year of the original purchase.

### **Specific Inclusions**

Bungee recoil cord  
Hand grips & foot straps  
Polyester rowing belt  
Seat  
All pulleys, rollers & bearings  
All rubber components  
Computer & speed sensor (excluding replaceable batteries)  
Footplates

### **General Exclusions**

Damage to the finish of any part of the machine  
Damage due to neglect, abuse, incorrect assembly or use of the machine  
Any charges for freight or customs clearance associated with the return or dispatch of parts  
Any damage to or loss of goods during transport of any kind  
Any labour cost associated with a warranty claim

### **General Conditions**

- The serial number of the machine must be correctly registered with FIRST DEGREE FITNESS Limited or one of its appointed distributors
- FIRST DEGREE FITNESS Limited reserve the right to examine any part where replacement is claimed under warranty
- Warranty period applies only to the original purchaser from the date of purchase and is not transferable
- The product must be returned to your place of purchase in original packaging with transportation, insurance and associated charges paid for by you and risk of loss or damage assumed by you
- FIRST DEGREE FITNESS makes no other warranties except as stated here and expressly disclaims all warranties not stated in this warranty. Neither FIRST DEGREE FITNESS nor its associates shall be responsible for incidental or consequential damages
- Manufacturer's warranty automatically commences upon sale of the product to end user or upon the expiration of one (1) year from month of manufacture, whichever occurs first



FIRST DEGREE FITNESS  
*Fluid* INNOVATION

*FITNESS PRODUCTS INSPIRED BY REAL LIFE*

[WWW.FIRSTDEGREEFITNESS.COM](http://WWW.FIRSTDEGREEFITNESS.COM)

CONTACT US

For customer support please visit  
[firstdegreefitness.com/support](http://firstdegreefitness.com/support)

TAIWAN

T: +886 3 478 3306  
764 Chung Shan South Rd  
Yangmei Taoyuan  
Taiwan R.O.C.

