

Istruzioni per il montaggio e l'installazione che devono essere seguite per l'utilizzo corretto delle barre parallele 260209 - 260210 PRO II
Obbligo di ancoraggio al pavimento in applicazione della norma UNI EN 12182 (2012).

Instructions à suivre impérativement pour l'assemblage, l'installation et l'emploi correcte des barres parallèles 260209 - 260210 PRO II
Obligation de fixer au sol, selon la norme NF EN 12182 (2012).

It is imperative to follow the instructions below to assure correct assembly, installation as well as correct use of the parallel bars 260209-210 PRO II
Obligation to anchor to the floor, according to DIN EN 12182 (2012).

Bitte befolgen Sie die Montageanleitung genau, um eine sachgerechte Montage, Installation und Verwendung des Gehbarren zu gewährleisten.
Verpflichtung zur Fixierung am Boden, nach Richtlinie DIN EN 12182 (2012).

Ref: ART. 260209 PRO II - 300 cm

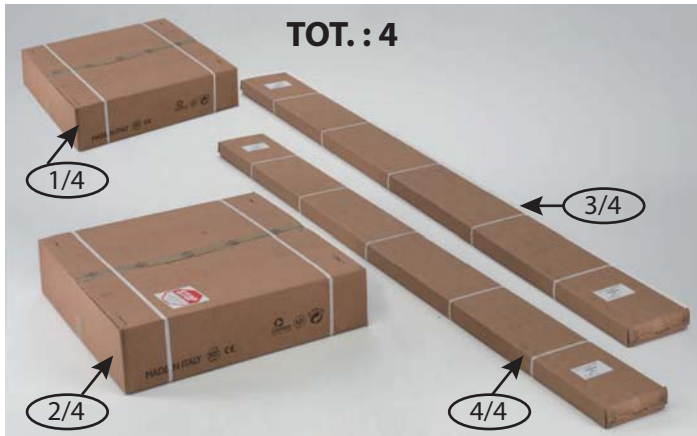

Ref: ART. 260210 PRO II - 400 cm

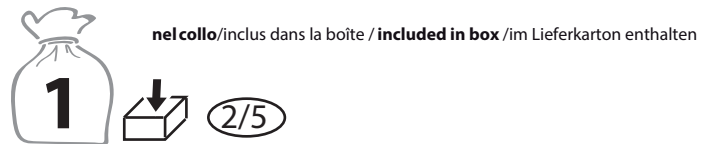
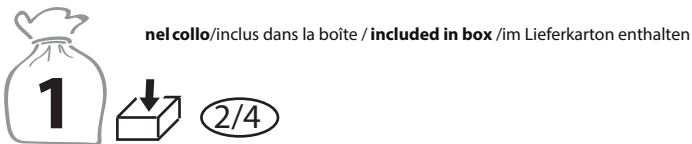
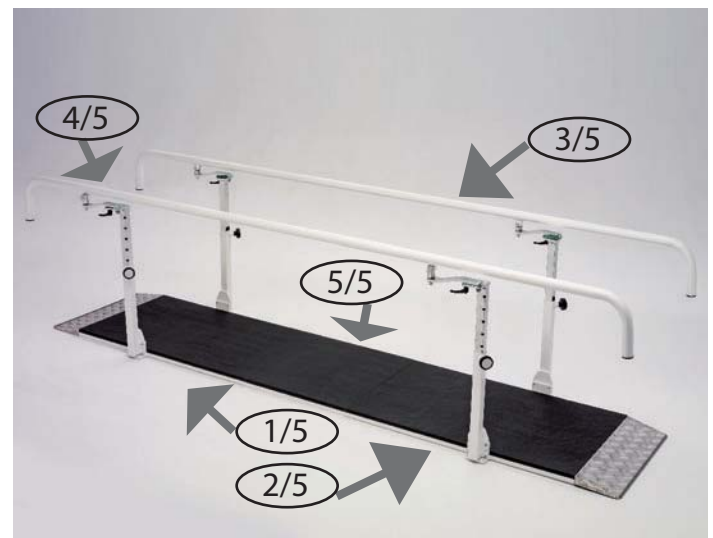
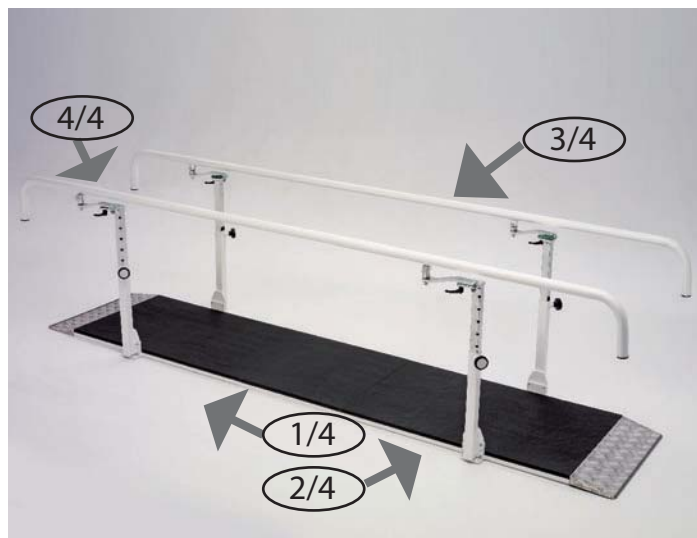

10 Pz.



M 8

10 Pz.



8 x 16



6 Pz.
M8 x 45



4 Pz.
M8 x 70

16 Pz.
M8 x 16



4 Pz.



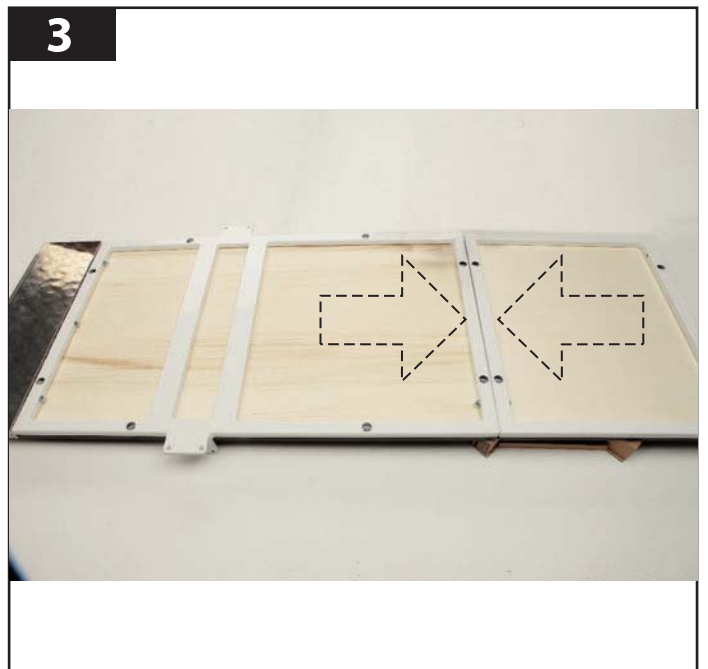
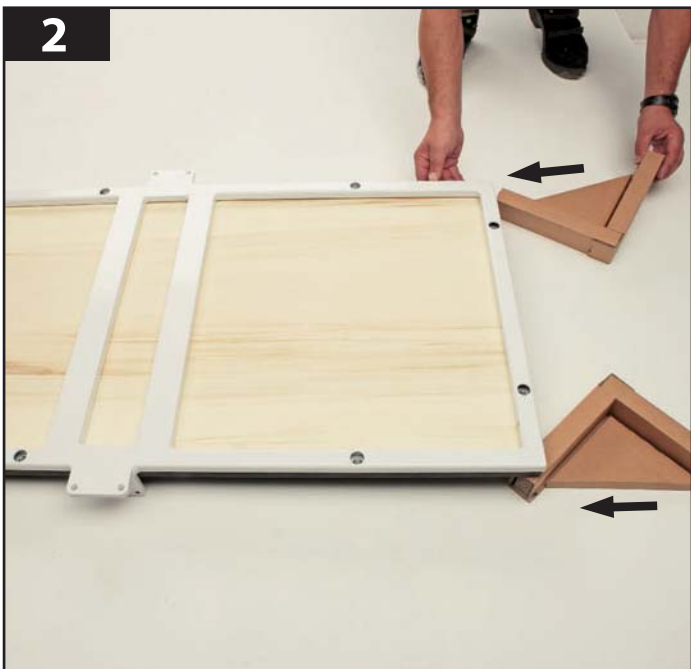
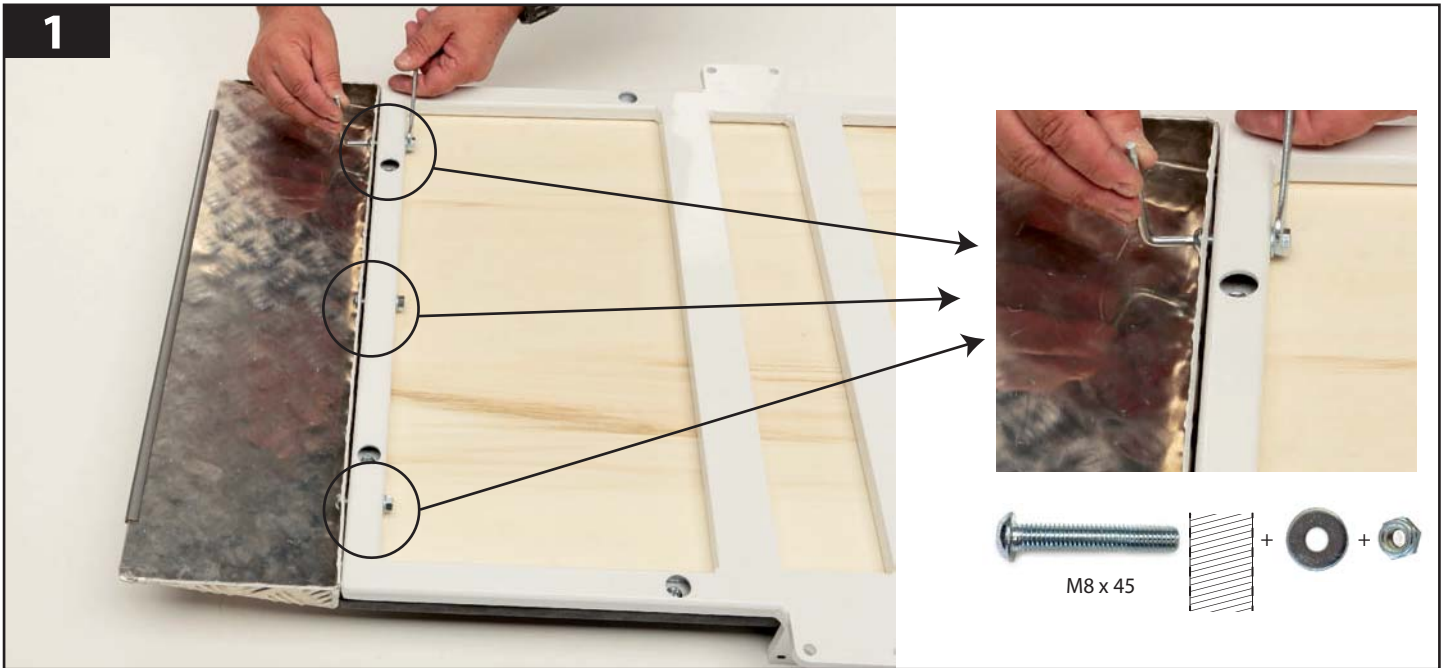
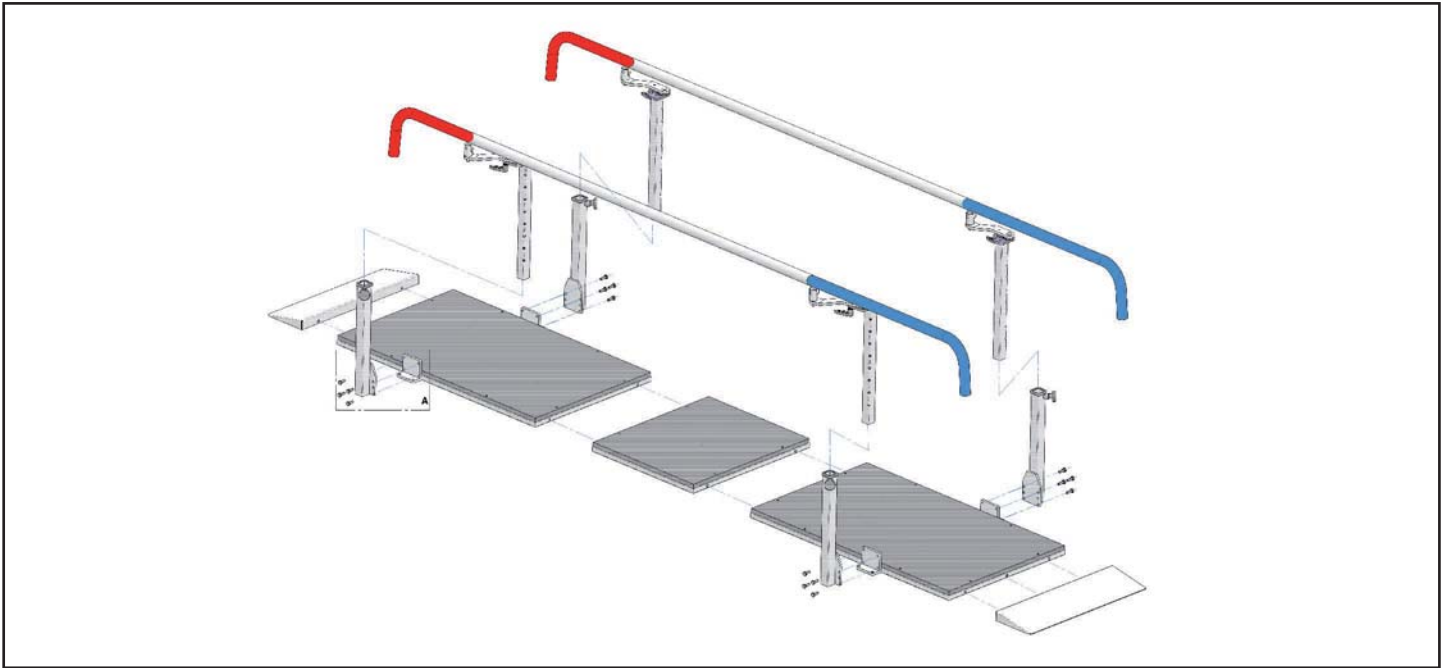

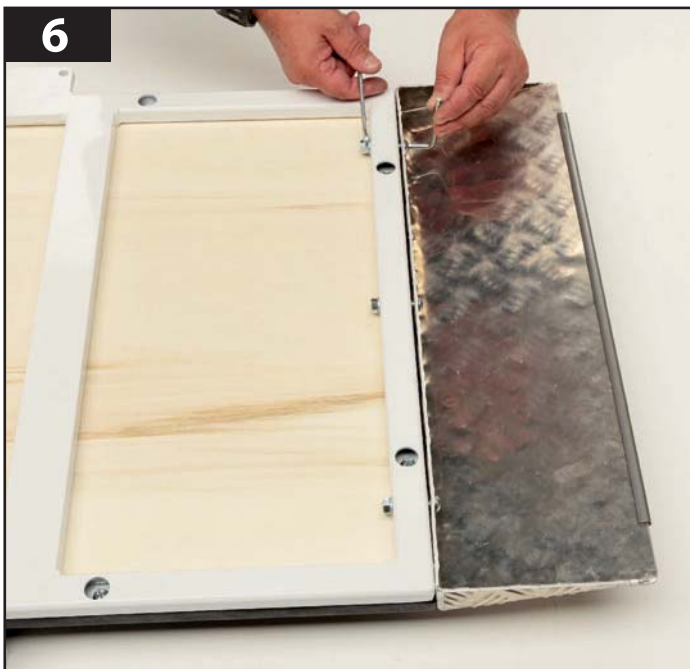
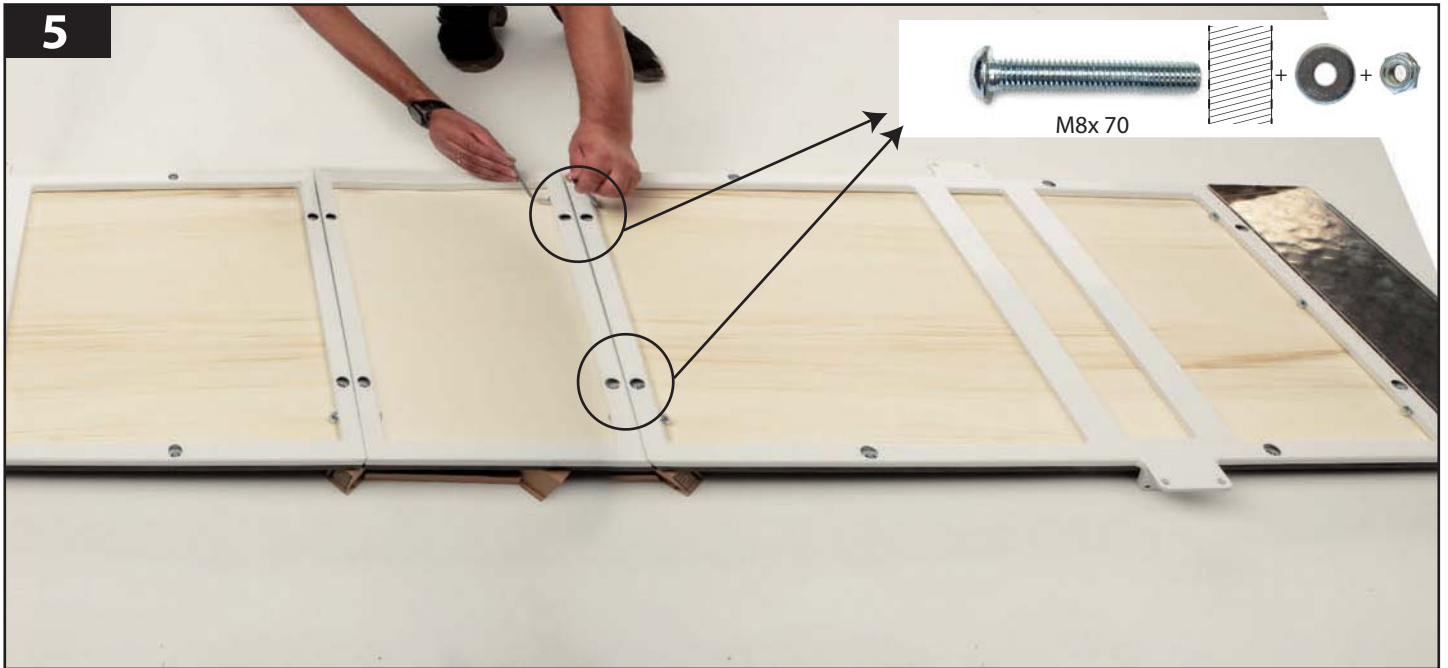
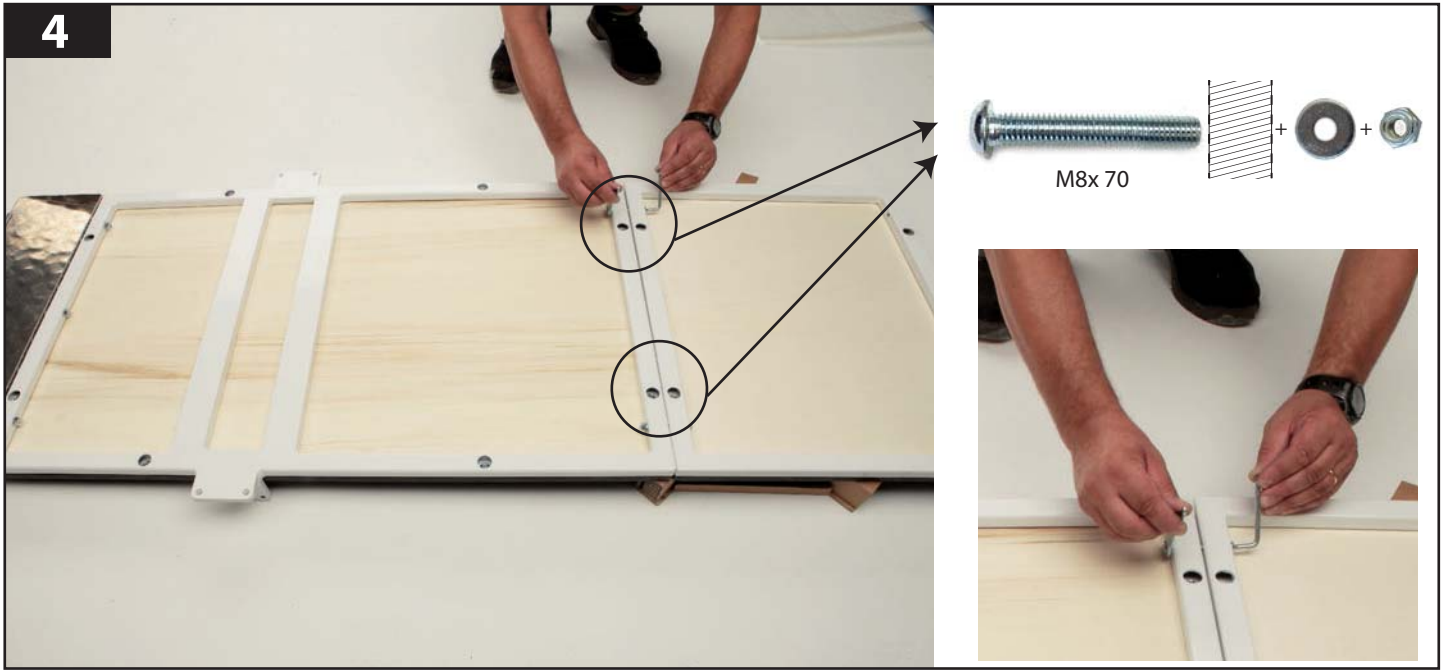

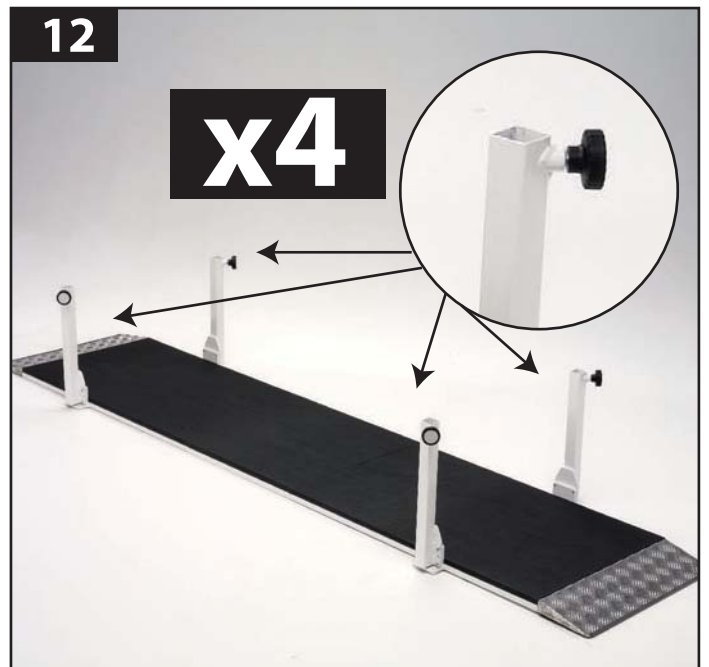
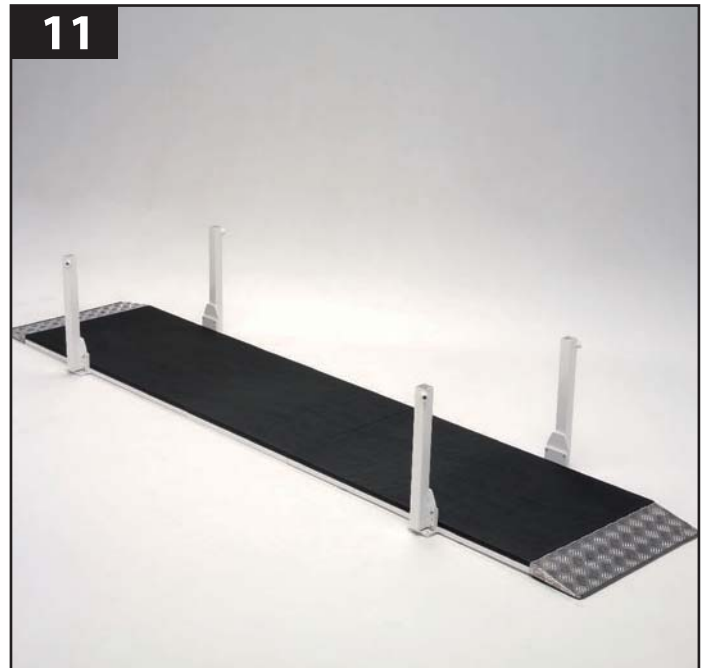
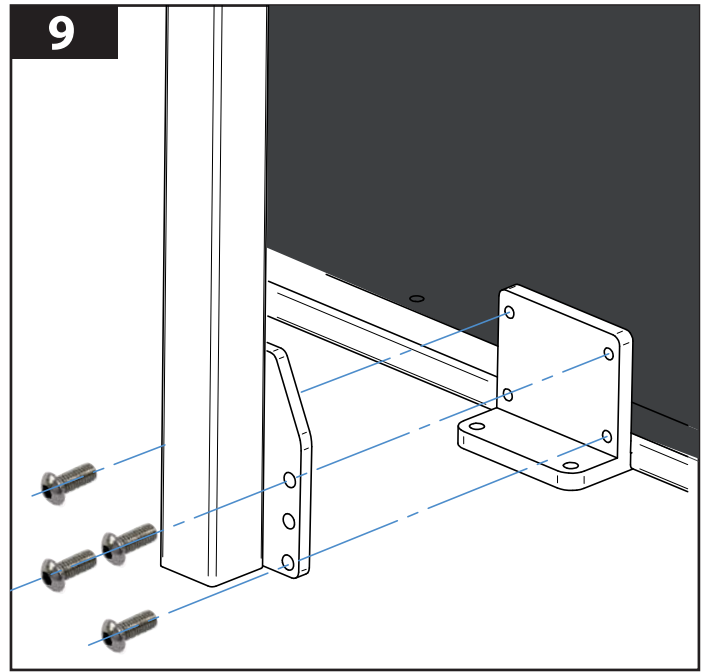
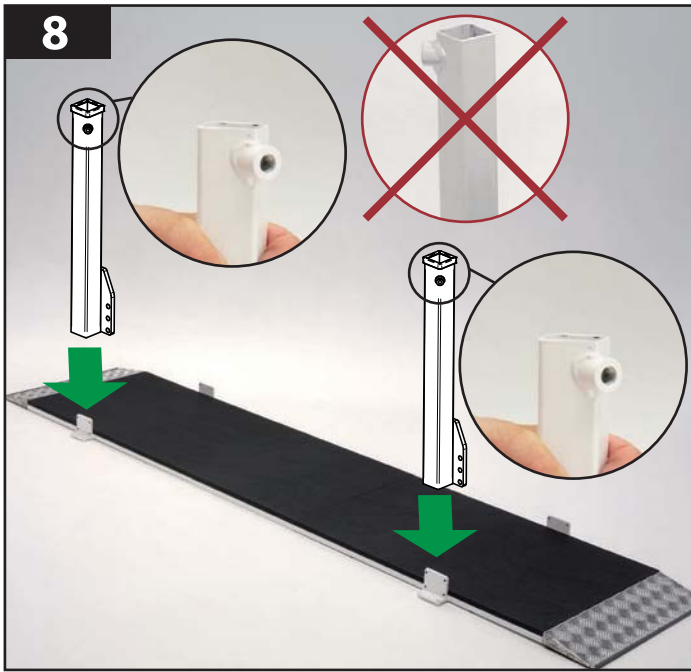

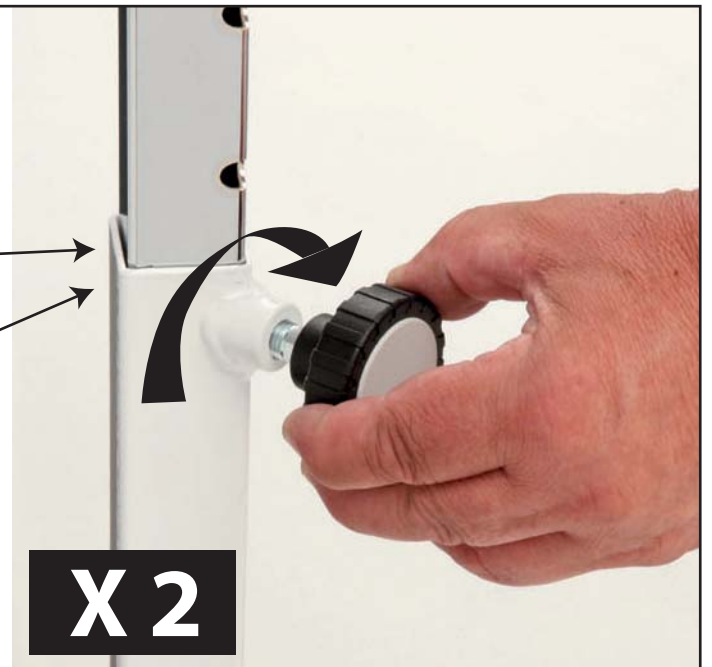
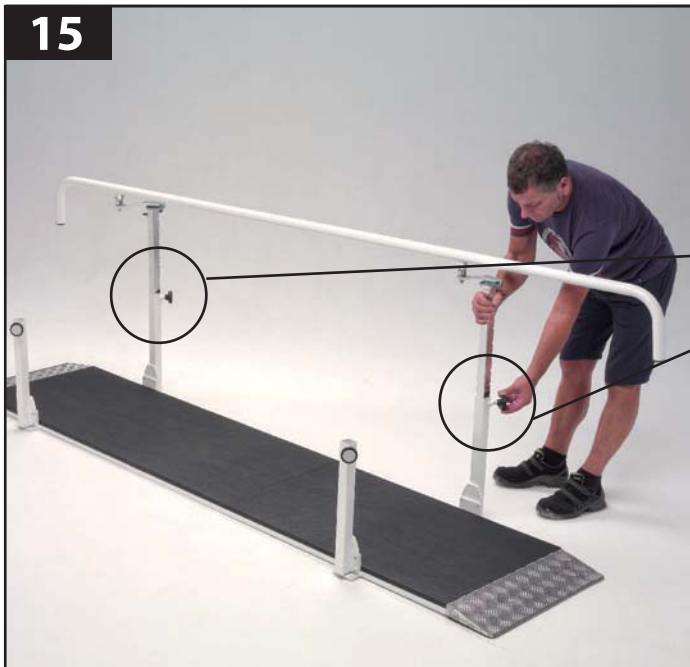
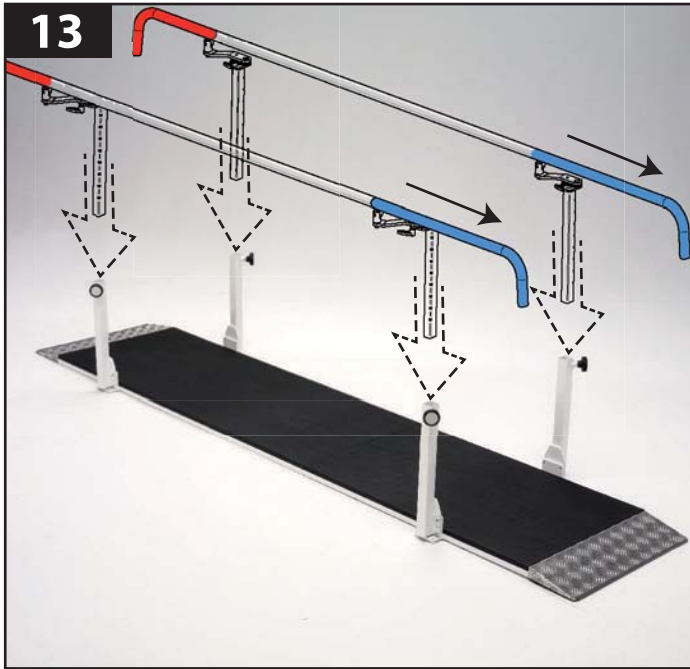

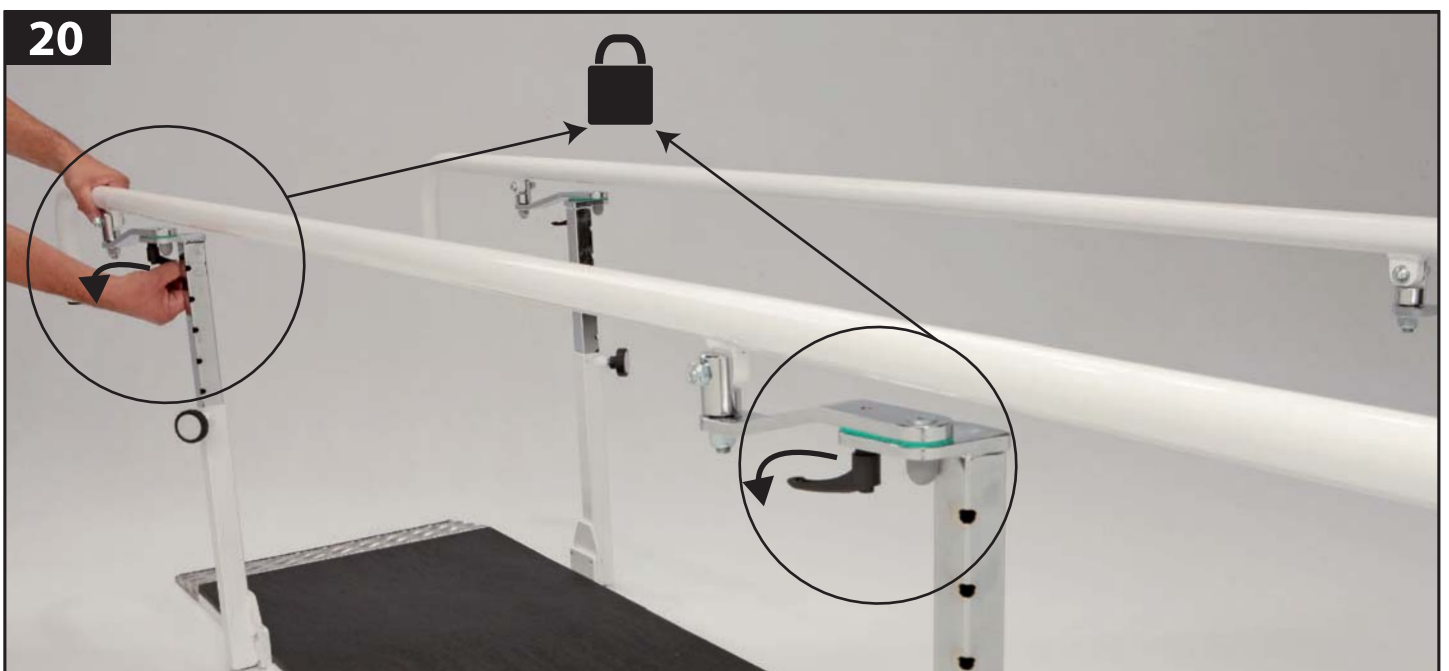
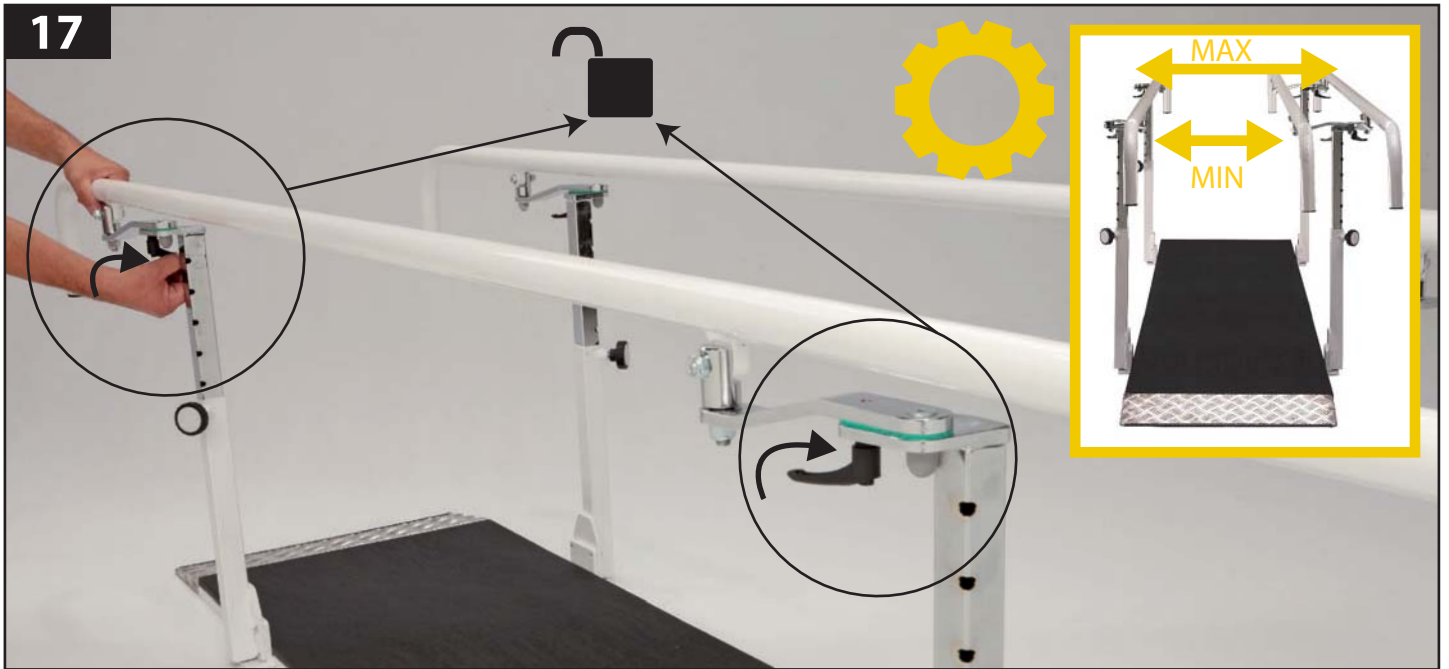

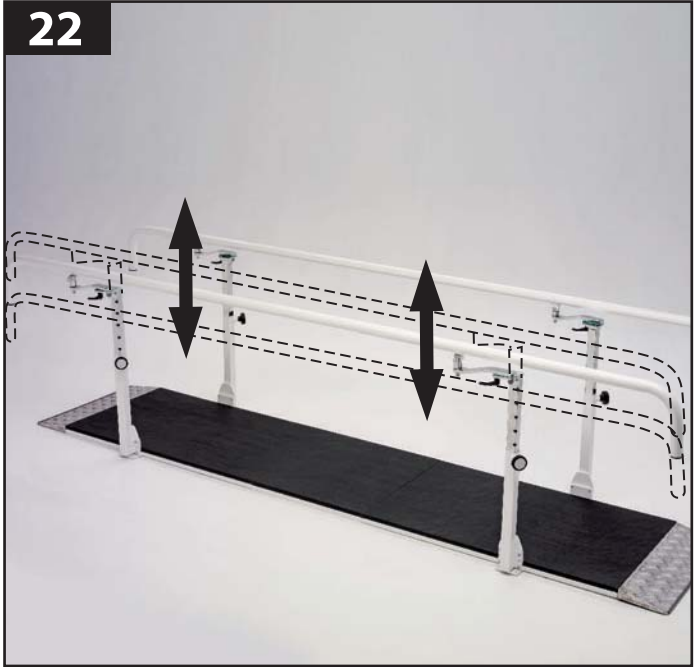
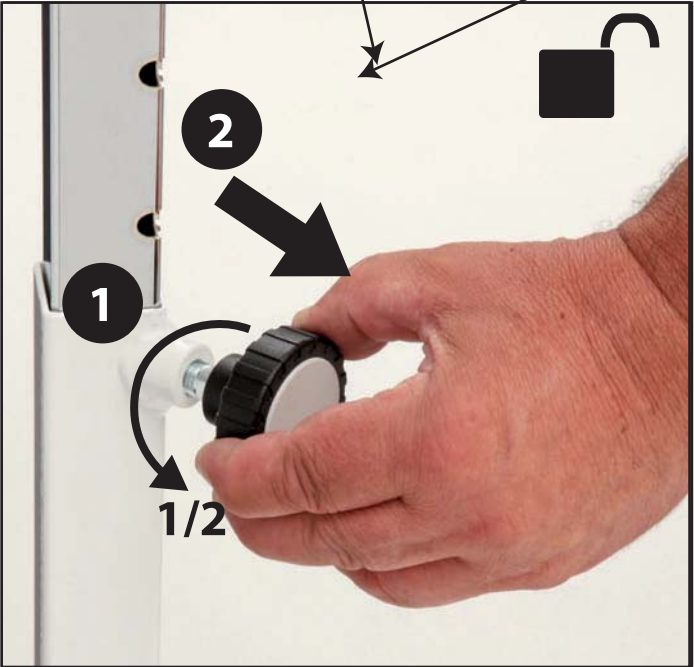
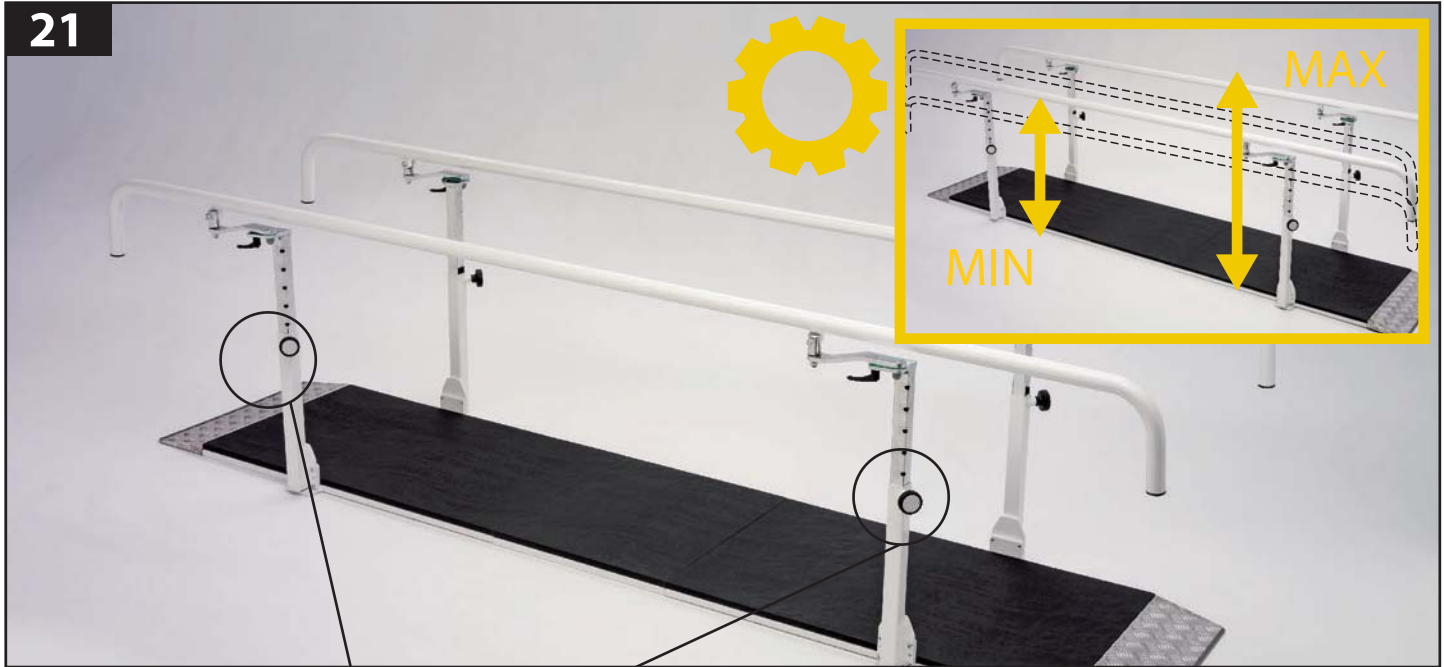

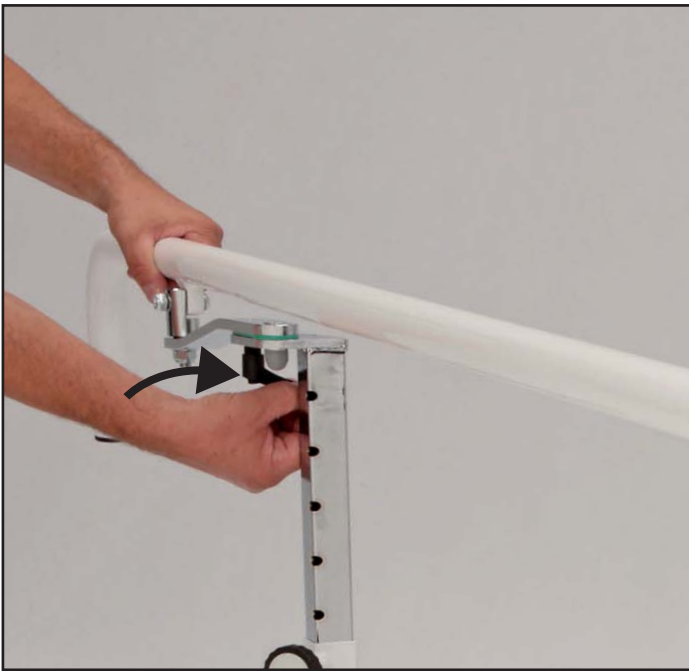
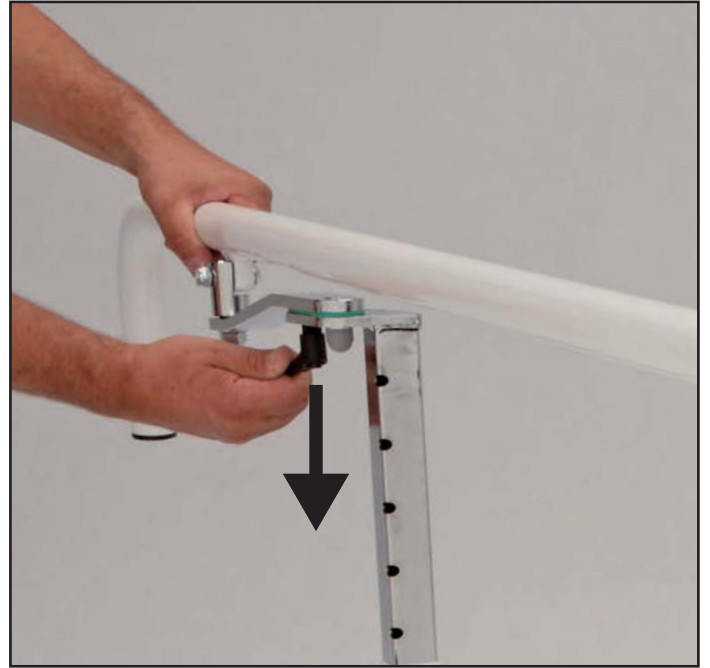







via del Lavoro,9 Z.I. - 31013 Codogné (TV) Italia

 Tel. +39 0438 777099

 Fax +39 0438 777091

 e-mail: info@ferrox.it www.ferrox.it



DICHIARAZIONE DI CONFORMITÀ
Déclaration de conformité

Fabbricante: FERROX s.r.l.
(Fabricant) Via del Lavoro 9
Z. I. - 31013 Codogné (TV) ITALIA
☎ +39 0438 777099 – 📠 +39 0438 777091
✉ :info@ferrox.it
C. F. - P. IVA - R. I. 03613220262

Dispositivo Medico PARALLELA PROFESSIONALE ADULTO/BAMBINO CON BASAMENTO/
(Dispositif Médical) **Barres parallèles professionnelles adulte/enfant avec socle**

Codici: 260209PRO II - 260210PRO II
(Codes)

Direttive Applicabili: DIRETTIVA 93/42/CEE concernente i dispositivi medici modificata dalla
(Directives Applicables) 2007/47/CE – recepita dal D.Lgs. n°46 del 24/02/1997 – modificato da D.Lgs. N°37 del 25/01/2010
(Directive 93/42/CEE concernant les dispositifs médicaux mise à jour avec la directive 2007/47/CE – reconnue par le D.Lgs n.46 du 24/02/1997 – modifié par le D.Lgs. N.37 du 25/01/2010)

Classificazione (Allegato IX D.Lgs. 46/97): Classe I (Regola 12)
Classification (Annexe IX, MDD 93/42): Classe I (Règle 12)

Procedura di valutazione della Conformità Allegato VII
(Procédure d'évaluation de la Conformité): (Annexe VII)

Con la presente si dichiara, sotto la propria esclusiva reu sponsabilità, che i prodotti sopra elencati soddisfano tutti i requisiti essenziali applicabili, previsti dall' Allegato I della Direttiva 93/42/CE concernente i Dispositivi Medici e alle norme applicabili.

(Nous déclarons, sous notre propre responsabilité, que les produits indiqués ci-dessus sont conformes à l'Annexe I de la Directive 93/42/CE concernant les Dispositifs Médicaux et les normes applicables)

Norme europee armonizzate applicabili
(Normes européennes harmonisées applicables)

La lista delle norme applicabili è riportata nel Cap.10 del Fascicolo Tecnico FT02.

(La liste des normes applicables est reportée au Chapitre 10 du Fascicule Technique FT02)

Il Fabbricante si impegna a conservare e a mettere a disposizione delle Autorità competenti la documentazione tecnica specificata nell' Allegato VII della Direttiva 93/42/CEE, per un periodo di 10 anni dalla data di ultima fabbricazione del prodotto.

(Le Fabricant s'engage à garder et à mettre à disposition des Autorités compétentes la documentation technique spécifiée dans l'Annexe VII de la Directive 93/42/CEE, pour une période de 10 ans à partir de la date de la dernière fabrication du produit).

Responsabile
(le Responsable)

Data: Set 2016
Date

Firma:
Signature:





DECLARATION OF CONFORMITY
Konformitätserklärung

Manufacturer: FERROX s.r.l.
(Hersteller) Via del Lavoro 9
Z. I. - 31013 Codogné (TV) ITALIA
☎ +39 0438 777099 – 📠 +39 0438 777091
✉ :info@ferrox.it
C. F. - P. IVA - R. I. 03613220262

Medical Device: PROFESSIONAL PARALLEL BARS WITH PLATFORM
(Medizinisches Gerät) Professioneller Gehbarren mit Bodenplatte

Codes: 260209PRO II - 260210PRO II
(Codes)

Applicable guidelines: (Directive 93/42/EEC concerning medical devices updated with Directive 2007/47/EC - recognized by the Legislative Decree no. 46 of 02.24.1997 - as amended by Decree Law no. N.37 of 25/01/2010)
(Geltende Richtlinien) (Richtlinie 93/42/EWG über Medizinprodukte mit der Richtlinie 2007/47/EG aktualisiert - durch das Dekret Nr. 46 vom 1997.02.24 anerkannt – berichtet durch Gesetzesdekret Nr. N.37 vom 25/01/2010)

Classification (Annex IX, MDD 93/42): Class I (Rule 12)
Einstufung (Anhang IX Dekrets Nr. 93/42): Klasse I (Regel 12)

Procedure for the assessment of conformity: Annex VII
(Konformitätsbewertungsverfahren): (Anhang VII)

We declare under our own responsibility that the products listed above are in compliance with Annex I of Directive 93/42/EC on medical devices and standards.
(Wir erklären in alleiniger Verantwortung, dass die oben genannten Produkte alle wesentlichen Anforderungen, für die in Anhang I der Richtlinie 93/42/EWG über Medizinprodukte und die geltenden Vorschriften, erfüllen).

Applied european harmonized standards The list of standards is reported in Chapter 10 of the
(Geltende harmonisierte europäische Standards) Technical File FT02.
(Die Liste der Regeln sind in Kapitel 10 des technischen Dokuments FT02 gezeigt.)

The manufacturer commits to keep and make available to competent authorities the technical documentation specified in Annex VII of Directive 93/42/EEC, for a period of 10 years from the date of the last manufacturing of the product.
(Der Hersteller verpflichtet sich die technischen Unterlagen gemäß Anhang VII der Richtlinie 93/42/EWG für einen Zeitraum von 10 Jahren ab dem Datum der letzten Herstellung des Produkts, zu lagern und zuständigen Behörden zur Verfügung zu stellen.)

The Manager
(Verantwortlicher)

Date: Sept 2016
Datum

Signature:
Unterschrift:

