

Instruction manual for street basketball unit

Thank you very much for choosing a **Sport-Thieme** product. Please read the instructions fully before you assemble the equipment so you can enjoy the product and its guaranteed safety:

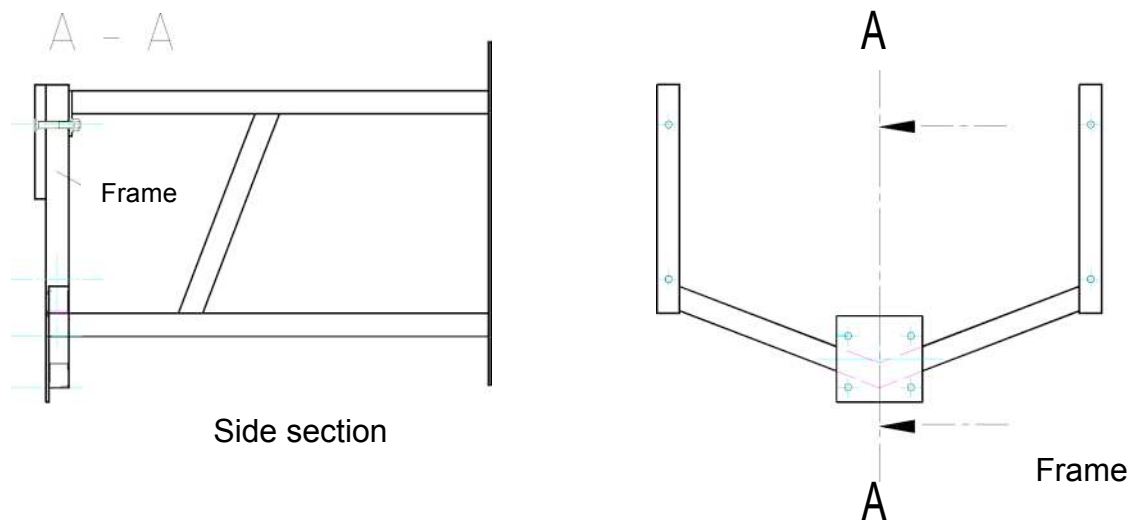

Illustration 1: street basketball wall bracket

Please check that all parts are included:

- 2x side section
- 1x frame
- 1x street basketball backboard
- 1x hoop
- 1x net
- Fixings (no wall fixing material)

1 Mounting the bracket on the wall

1.1 Position the unit

Select a suitable position for the wall bracket. Ensure that there is sufficient space around the unit for the game to be played.

1.2 Attach the side sections to the supporting structure (wall or similar)

Take the loads given in illustration 2 (in compliance with **DIN 7899**) into account when attaching the street basketball wall bracket to a wall or another supporting structure.

The supporting structure must safely support this load.

Consult a **structural engineer** to judge the supporting structure's maximum load and choose the corresponding fixing material!

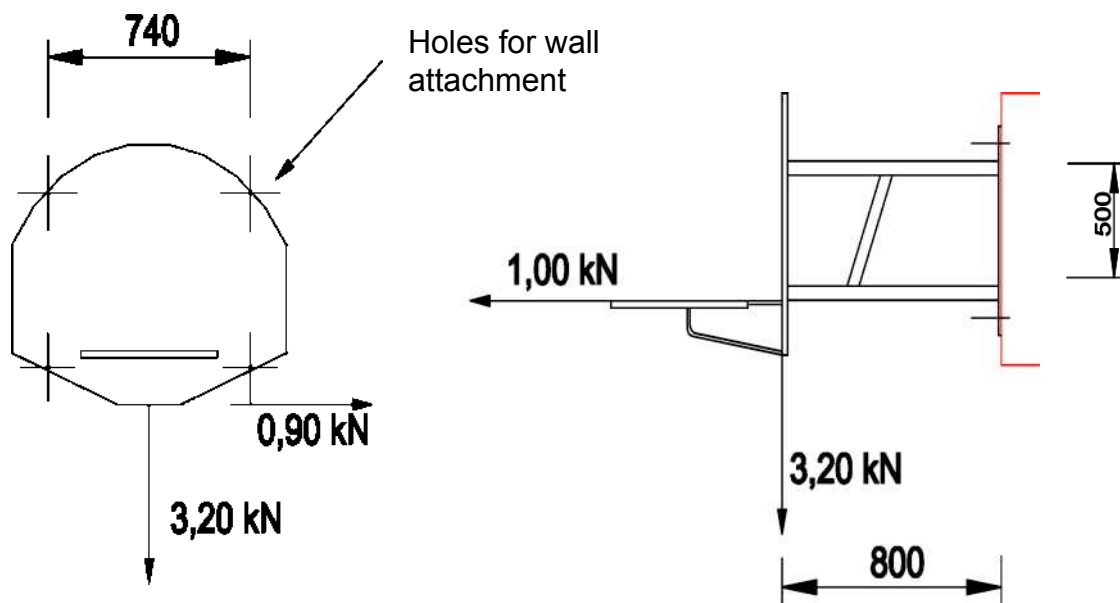

Illustration 2: load in compliance with DIN 7899

The corresponding wall plug material is NOT included.
Please consult a specialist (structural engineer) regarding
suitable fixing material for the supporting structure.

To attach the basketball bracket, drill the holes into the existing supporting structure (corresponding to illustration 3).

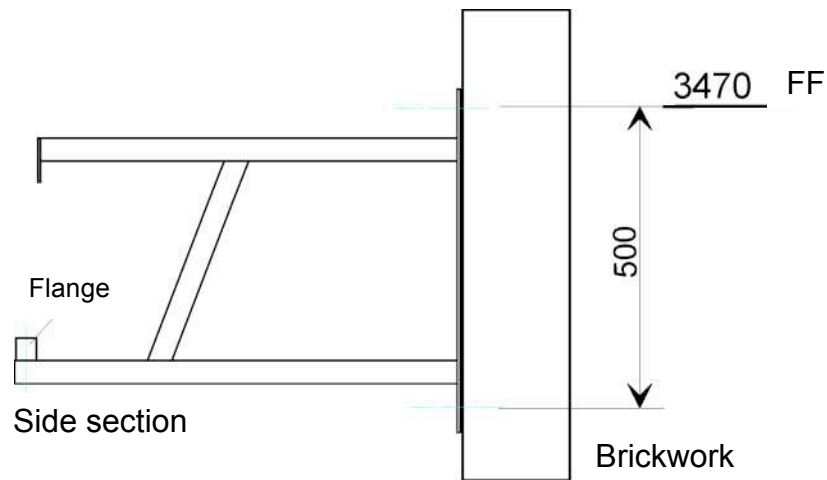

Illustration 3: side section assembly on brickwork

To ensure that you can mount the basketball hoop at a height of 3050 mm (competition height), the holes for the side sections must be drilled at a height of +3470 mm FF (finished floor level) and at +2970 mm FF (500 mm perpendicular beneath) (see illustration 3).

Next, screw the side section to the wall using the suitable fixing material. For the second wall bracket, repeat the process at a horizontal distance of 740 mm to the previous holes (see illustration 4).

CAUTION!

Ensure that the bracket is fixed the right way around! The flange must sit at the bottom (see illustration 3).

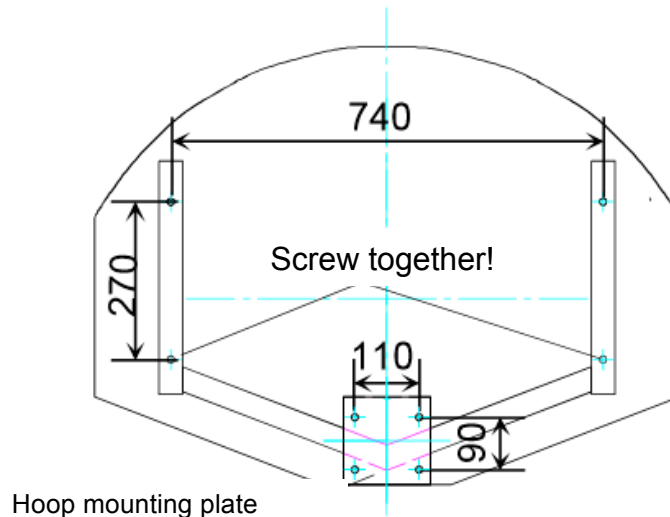

Illustration 4: attaching the backboard to the frame

2. Mount the street basketball backboard on the frame

Place the frame onto the rear of the backboard.
Align the frame so that it is centred and the hoop mounting plate's lower edge is flush with that of the street board (see illustration 4).
Mark the holes and drill with a 12 mm drill bit (also see illustration 4 for dimensions).
Also drill the four openings for the hoop attachment.

Screw ONLY both of the backboard's lower attachment points a little bit to the frame (A, see illustration 4 and 5). Use the coach bolts M 10 x 70 included (with semi-circular head), washer, spring washer and hex nut.

2.1 Attachment of the frame onto the side sections

1. Place the frame with the street board on the side sections' flanges (if required, loosen the bolts (A) slightly).
2. Now, connect the frame's upper holes (B) and the plates on the side sections (see illustration 5). Use the coach bolts M 10 x 60 provided for this.
Now, tighten the bottom bolts (A).

