

Operating/assembly instructions**Sport-Thieme parallel bars**

Product code: 120 8405, 120 8418, 120 8421

Operating/assembly instructions Sport-Thieme parallel bars

Thank you very much for choosing a **Sport-Thieme** product. Please read the instructions fully before you assemble the equipment so you can enjoy the product and its guaranteed safety:

**1. Description**

All bars models comply with DIN 7901 'parallel bars with inlay mat', including DIN EN 914 'parallel bars and combined asymmetric bars/parallel bars'. The regulations described there, with regards to area of use, inspection, measurements and maximum loads, apply.

The uprights are attached to the welded base frame with cast bells. The cross girders are closed off with special rubber inserts which are floor-friendly and protect the sides when moving the apparatus. The generously sized castors, which can be lowered using a handle, are housed in the cast bells.

Adjust height and horizontal position using a double secured clamping lever.

The respective technical regulations valid at the time of delivery apply to design, function and use of the apparatus (the edition at the time of delivery is valid).

Operating/assembly instructions**Sport-Thieme parallel bars****Product code: 120 8405, 120 8418, 120 8421****2. Use**

Depending on their norm compliant design, bars are a sports apparatus for competition, club training and school sports. In addition to the norm, the guidelines of the national and international artistic gymnastics federations apply to the intended use.

Always ensure appropriate and safe operation. Check that all bolts sit correctly after setting up and before actually using the bars. Carry out a visual check of the apparatus before and after each use. In the areas where the bars and uprights are mounted, in particular, ensure that all connections are faultless and check for possible tears. Should defects like these occur, the apparatus must not be used!

3. Improper use

Improper use voids the manufacturer's warranty and guarantee obligations. This includes changes to parts of the apparatus or to the entire apparatus as well as exceeding the permitted loads.

4. Assembly

Assembly is done by the customer only.

We deliver the bars without pre-drilled holes. For mounting, place the bars on the bar brackets and mark the drilling holes on the bars. For this, the bar brackets must be lengthways of the cross girders. After that, pre-drill the bars. Before screwing them into the pre-drilled holes, the special screws M8x35 should be dipped in standard grease. This prevents the screws from breaking off during the bars' assembly. You must also ensure that the screws are not tightened any further once the screw head is in contact with the bar bracket. This prevents the screw head from turning off or being damaged. We recommend mounting the bars using a hand-operated ratchet with a suitable bit.

The apparatuses are almost maintenance-free, only the joints, shafts and axles should be greased using a non-dripping lubricant. From time to time, the bar posts should be wiped using an oily cloth.

Operating/assembly instructions**Sport-Thieme parallel bars**

Product code: 120 8405, 120 8418, 120 8421

5. Operation

For transportation, lower the castors by turning the transport lever by 180°.

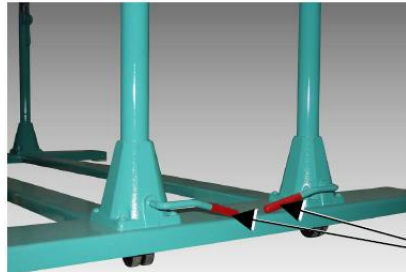

Transport lever

You can now move the bars to the required location.

Please ensure that no people are on the bars during transport. At the required location, the castors be slowly retracted.

To adjust the bars' height, release the clamp fastener using the clamp lever (1) and pull out the bars to the desired height (2) simultaneously and as parallel as possible. Never pull out the bar posts completely. The safety catch must always be engaged and keep the post in the last position.

In order to adjust the width between the bars, turn them inwards or outwards on the posts using the crank (3). Now close the clamp fastener again (1).

To lower the bars, release the clamp fastener (1), lift the bar slightly and press the catch (4).

After that, push the bar posts with the bars slowly into the uprights (2) and close the clamp fastener again (1).

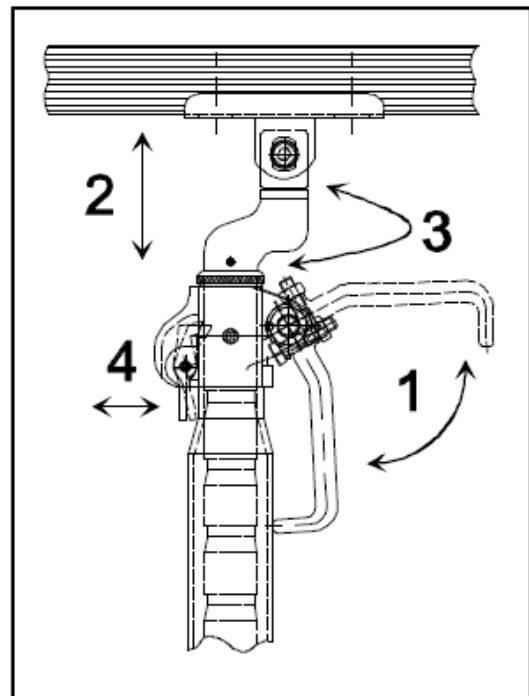

Operating/assembly instructions**Sport-Thieme parallel bars**

Product code: 120 8405, 120 8418, 120 8421

6. Hazard warning

- When lowering the castors or the bars, no one is permitted to be in the bars' danger zone.
- When lowering the bars, do not hold on to their posts. There is a risk of crushing.
- Be careful when setting up and removing the bars, there is a risk of crushing.
- The apparatus must only be used by authorised and qualified people.
- Always firmly tighten all of the screws.
- Improper handling can lead to damage and tears to frame, bars, uprights and castors. Therefore, these parts in particular should be checked before, during and after use.

Assembly is done by the customer only. The apparatuses are almost maintenance-free, only the joints, shafts and axles should be greased using a non-dripping lubricant. From time to time, the bar posts should be wiped using an oily cloth.

Caution: Do not overload the equipment!

**Maintenance and care instructions****Instructions:**

Carry out a visual check at regular intervals. Due to our continuous quality control of the products, technical changes may occur which may lead to slight deviations in the instructions.

Check at regular intervals that the screw connections are tight. Check the equipment for possible damage and replace worn-out parts. Check the condition of wooden elements as chipping and other signs of wear can result from use. Ensure that moveable parts are free-moving.

We are happy to answer any questions you may have.

Your **Sport-Thieme** Team