

READ, KEEP & FOLLOW THESE SAFETY INSTRUCTIONS

- Product to be assembled by an adult.
- Always use under adult supervision.
- Always use the harness.
- This product is a toy, it is not to be used as a restraint.
- Inspect for damage before each use.
- Do not assemble or use if parts are missing or damaged.

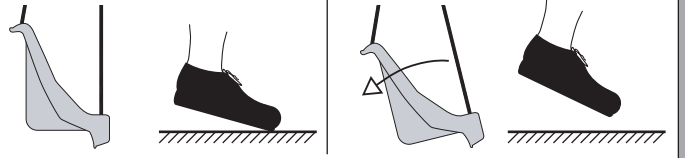

Adjust ropes to tilt seat backwards so that feet cannot touch the floor.

CONTENTS

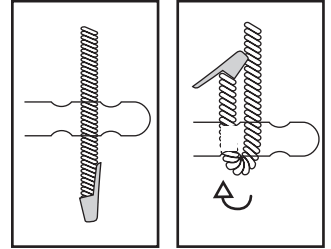
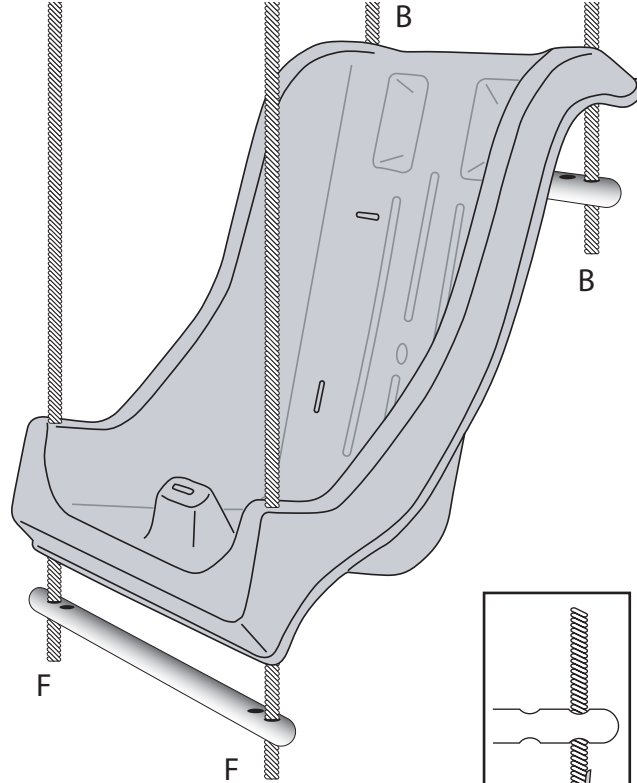
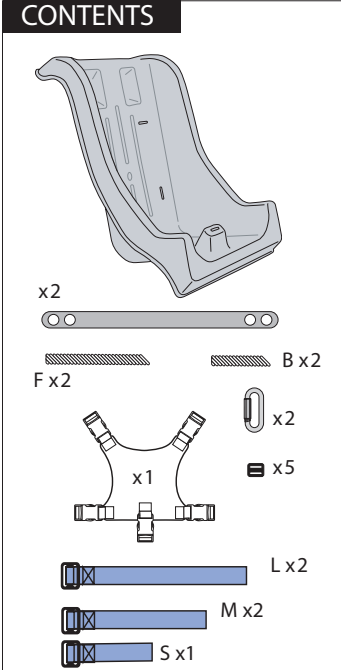

Short Ropes to the Back
Long Ropes go to the Front

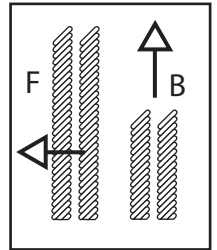
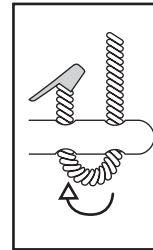
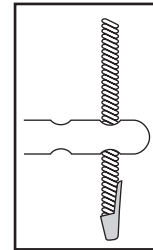
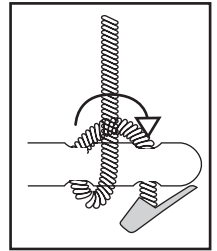

Pass the 5 Harness Anchors through the holes from Back to front.

The Short Anchor goes through the Pommel

The Longest are for the Shoulders.

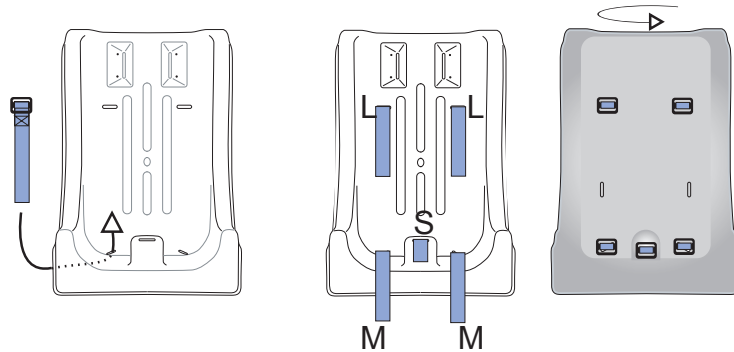

All swing seat harnesses are potentially an entanglement and strangulation hazard and their use should always be supervised.



If your swing is in a location where it is not always possible to forsee when it will be used and by whom then you should remove the harness.

Add a Triglide to each Harness Anchor.

Then Join to the 5 Male Clips found on the Harness

Adjust to fit and secure by passing back through the triglide

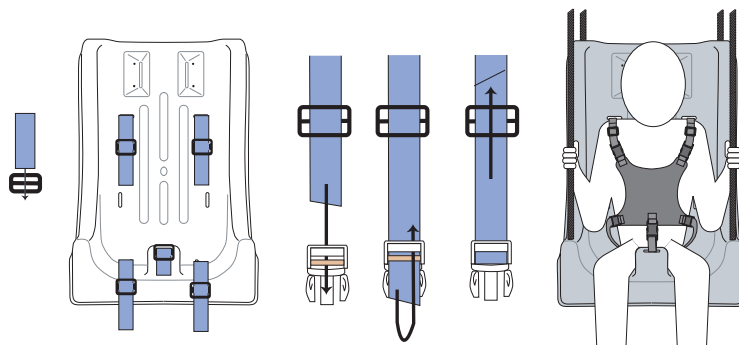



SAFETY

The safety of your child depends on these instructions.

This is an activity toy with moving parts.

Regular checks are essential, in order to prevent the toy from becoming a hazard.

MAINTENANCE

Make deliberate and thorough checks at the beginning of each season.

- Check Swing Seat's body, ropes (or chains) & clips and pay particular to the highest (moving) point of attachment for evidence of deterioration.
- Do not use the Swing Seat if there is evidence of deterioration. Contact TFH for replacements, which should be installed in accordance with instructions.

ACCESSORIES

Changes to the Swing Seat must be carried out according to instructions from TFH.

