



twall® Premium64 standard Color mobile / stationary

Interactive Sport and Training Device

THE INTERACTIVE
TOUCH WALL



User Manual Rev. 1.0.3
Data CD

Table of Content:

Hardware documentation

1	Product description -----	4
1.1	Intended use-----	4
2	Scope of delivery -----	5
2.1	Overview - scope of delivery of the twall®Premium64 mobile-----	5
2.1.1	Detailed list of components including assembly steps -----	5
2.2	Overview - scope of delivery of the twall®Premium64 stationary -----	7
2.2.1	Detailed list of components including assembly steps -----	7
3	Assembly -----	9
3.1	Mobile installation of the twall®Premium64 mobil-----	9
3.1.1	Storage space requirements-----	9
3.1.2	Assembly principle of the profile connectors -----	9
3.1.3	Assembly instructions -----	10
3.1.3.1	Assembling the frame base -----	10
3.1.3.2	Assembling the aluminium frame-----	12
3.1.3.3	Assembling the basic modules-----	15
3.2	Stationary installation of the twall®Premium64-----	18
3.2.1	Storage space requirements -----	18
3.2.2	Assembly instructions -----	18
3.2.2.1	Assembling the aluminium frame-----	18
3.2.2.2	Assembling the basic modules-----	22
4	Maintenance -----	22
5	Troubleshooting -----	22
6	Technical specifications -----	23
6.1	Data sheet twall®Premium64 mobile and stationary-----	23
6.2	Data sheet – Accessories-----	23

Software Documentation

7	Operating the twall® without a computer -----	24
7.1	Executing twall® Programmes-----	24
7.2	Viewing high scores -----	25
7.3	Settings-----	25
8	Operating the twall® with a computer -----	26
8.1	Connecting to the computer-----	26
8.2	Driver installation -----	26
8.2.1	Driver installation under Microsoft Windows XP® -----	26
8.2.2	Driver installation under Microsoft Windows Vista®-----	27
8.2.3	Driver installation under Microsoft 7® -----	28
8.3	Software installation -----	29
8.4	Description of the software -----	30
8.4.1	The start page -----	30
8.4.2	Programme settings -----	30
8.4.2.1	Settings of the standard screensaver -----	30
8.4.3	Executing the twall® programme -----	30
8.4.3.1	Saving programmess on the twall®-----	31
8.4.3.2	High scores-----	32
8.4.4	Simulating the twall® programmes-----	32
8.4.5	Creating new twall® programmes -----	33
8.4.6	Editing twall® programmes -----	35
8.4.7	Editing sound sets -----	35
8.5.	Firmware update-----	36
9	Service -----	37

Hardware documentation

1 Product description

The tWall® is an interactive sports device using light pulses to specifically initiate motion sequences. The tWall consists of large, evenly arranged pads containing colour signals lit and deactivated by touch - for the training of sterical movement. Depending on the training sequence used condition, agility, the ability to respond, and if required specific muscular endurance can be trained. The tWall®'s colour elements can be preconfigured to illuminate at selective or random positions, speeds and sequences.

The primary task: use reflexes to deactivate the displayed light as quickly as possible!

The software-controlled program sequence provides both individual training and group training. By configuring the touch elements individually, it is possible to adjust tWall® training settings according to size, scope of activity, visual perception and the preferred tactile situation of the user. Furthermore, product version tWall® colour allows to integrate cognitive tasks using various colours and sounds.

Additionally, the tWall® design features a small construction depth, allowing easy integration into existing room concepts.

1.1 Intended use

The use of the tWall® is intended for stimulating human movement or for the creation of lighting effects. It is strictly recommended that the operator checks if the training program suits the physical aptitude of the training person. The tWall® should be operated by the provided power supply unit only.

Related to emitted interference, the tWall® complies with class A limits according to EN55022.

Continuous operation of a single or all touch pads is not permitted as it can lead to a strong heating of the LED (light-emitting diode) modules. Sequences that force a single or all touch pads to light up for longer than 2 minutes are prohibited and can cause the loss of warranty.

2 Scope of delivery

2.1 Overview - scope of delivery of the tWall®Premium64 mobile

- A1** 1 x Frame base
- A2** 1 x Aluminium frame
- A3** 4 x tWall® Basic modules
- A4** 4 x Weights
- B1** 1 x Stainless steel frame cover left with bar code of the tWall®
- B2** 1 x Stainless steel frame cover right incl. control panel with power supply jack and power supply witch (connections for further equipment such as loudspeakers or headsets are available)
- B3** 2 x Stainless steel frame covers (top/bottom)
- C** Accessories (included in scope of delivery)
- D** Required tools (not included in scope of delivery)
- E** User manual and data-CD

2.1.1 Detailed list of components including assembly steps

- ▼ **A1** 1 x Frame base consisting of:
 - A1a** 1 x Frame base profile 45 x 90 x 2023 mm | 1.77 x 3.54 x 79.65 inch
 - A1b** 1 x Frame base profile 45 x 90 x 1933 mm | 1.77 x 3.54 x 76.10 inch
 - A1c** 2 x Frame base profiles 45 x 90 x 1055 mm | 1.77 x 3.54 x 41.54 inch
 - A1d** 2 x Frame base profiles 45 x 90 x 910 mm | 1.77 x 3.54 x 35.83 inch
 - A1e** 4 x Profile angles 30 x 30 x 5 mm | 1.18 x 1.18 x 0.20 inch
 - A1f** 4 x Joints for the angles braces
 - A1g** 2 x Angles braces 45 x 45 x 1900 mm | 1.77 x 1.77 x 74.80 inch

Assembling the frame base – three steps:

I. Mounting the frame base profiles

- 20 x Profile connectors (of which 4 are provided for the side supports at the aluminium frame)
- 4 x Rubber feet (black, adhesive)
- 4 x Cover caps (black, plastic)

II. Attaching the profile angles to the frame base

- 12 x Fillister head screws with flange **M8x16** (3 per angle)
- 12 x T-nuts **M8** (3 per angle)

III. Fastening the joints to the angles braces

- 16 x Adjusting blocks for the joints
- 4 x Joints for angle braces
- 4 x Socket head screws **M8x25** to fit the joints to the angle braces
- 4 x Washers
- 4 x Socket head screws **M8x16** to fit the joints to the frame base and the aluminium frame
- 4 x Washers
- 4 x T-nuts **M8** to fit the joints to the frame base and the aluminium frame

- ▼ **A2** 1 x Aluminium frame consisting of:
 - A2a** 2 x Side supports 45 x 90 x 2250 mm | 1.77 x 3.54 x 88.58 inch
 - A2b** 1 x Shield 8 mm | 0.32 inch
 (continued on next page)

A2c	4 x Frame profiles long	45 x 45 x 1933 mm 1.77 x 1.77 x 76.10 inch (of which one with pre-assembled PVC installation channel)
A2d	2 x Frame profiles short	45 x 45 x 840 mm 1.77 x 1.77 x 33.07 inch
A2e	8 x Profile angles	28 x 28 mm 1.10 x 1.10 inch

Assembling the aluminium frame – three steps:

I. Mounting the frame profiles

- 8 x Profile connectors
- 2 x Cover caps (black, plastic)
- 4 x Combination profiles (grey, PVC)

II. Attaching the profile angles to the frame profiles

- 16 x T-nuts **M6**
- 16 x Fillister head screws **M6x14** with flange (2 per angle)

III. Fastening the angles braces

(Components included in assembling the frame base)

- ▼ **A3** **4 x Basic modules consisting of:**
- A3a** **1 x Basic module top left with manifold PCB (printed circuit board)**
- A3b** **1 x Basic module bottom left**
- A3c** **1 x Basic module top right with manifold PCB with line filter**
- A3d** **1 x Basic module bottom right**

Assembling the basic modules – two steps:

I. Setting up the basic modules

- 8 x T-nuts **M8**
- 8 x Socket head screws **M8x30**
- 8 x Washers

II. Connecting the basic modules to the control panel

- 16 x **14-stranded** flat ribbon cables to connect to the manifold PCBs marked as 0.1 - 0.4, 1.1 - 1.4, 2.1 - 2.4 and 3.1 - 3.4
- 2 x **26-stranded** flat ribbon cables to connect to the control panel (marked as A and B)
- 1 x **double-pole** power supply cable including connectors 1 and 2 in pre-assembled PVC installation channel

- ▼ **A4** **4 x Weights**

- ▼ **B1** **1 x Stainless steel frame cover left** with bar code of the twall®
- B2** **1 x Stainless steel frame cover right** incl. control panel with power supply jack and power supply switch (connections for further equipment such as loudspeakers or headsets are available)
- B3** **2 x Stainless steel frame covers** (top/bottom)

Assembling the stainless steel frame covers:

- 11 x Fillister head screws **M6x10**

- ▼ **C** **Accessories** (included in scope of delivery)

- C1** **1 x Power supply line** (with Euro connector)
- C2** **1 x USB cable** (A/B)
- C3** **1 x Adapter** (power supply unit)
- C4** **1 x Set of Allen keys** (4 mm, 5 mm and 6 mm | 0.16 inch, 0.20 inch and 0.24 inch)

- ▼ **D** **Required tools** (not included in scope of delivery)

- Stepladder
- Spirit level
- Measuring tape
- Slot screwdriver **9 mm | 0.35 inch**

▼ **E User manual and data-CD**

2.2 Overview - scope of delivery of the twall®Premium64 stationary

- A2 1 x Aluminium frame**
- A3 4 x twall® Basic modules**
- B1 1 x Stainless steel frame cover left** with bar code of the twall®
- B2 1 x Stainless steel frame cover right** incl. control panel with power supply jack and power supply switch (connections for further equipment such as loudspeakers or headsets are available)
- B3 2 x Stainless steel frame covers (top/bottom)**
- C Accessories (included in scope of delivery)**
- D Required tools (not included in scope of delivery)**
- E User manual and data-CD**

2.2.1 Detailed list of components including assembly steps

- ▼ **A2 1 x Aluminium frame consisting of:**
- A2a 2 x Side supports** 45 x 90 x 2250 mm | 1.77 x 3.54 x 88.58 inch
 - A2b 1 x Shield** 8 mm | 0.32 inch
 - A2c 4 x Frame profiles long** 45 x 45 x 1933 mm | 1.77 x 1.77 x 76.10 inch
(of which one with preassembled PVC installation channel)
 - A2d 2 x Frame profiles short** 45 x 45 x 840 mm | 1.77 x 1.77 x 33.07 inch
 - A2e 8 x Profile angles** 28 x 28 mm | 1.10 x 1.10 inch
 - A2f 4 x Angles for wall fastening** 86 x 86 x 43 mm | 3.39 x 3.39 x 1.69 inch

Assembling the aluminium frame – four steps:

I. Mounting the frame profiles

- 8 x Profile connectors
- 2 x Cover caps (black, plastic)
- 4 x Combination profiles (grey, PVC)

II. Attaching the profile angles to the frame profiles

- 16 x T-nuts **M6**
- 16 x Fillister head screws with flange **M6x14** (2 per angle)

III. Attaching the angles for wall fastening

- 8 x Verbus-Ripp-screws **M8x20** (hexagon socket)
- 8 x T-nuts **M8**

IV. Setting up the aluminium frame

- 4 x Plastic dowels **10x70**
- 4 x Plastic dowels **10x100**

- ▼ **A3 4 x Basic modules consisting of:**
- A3a 1 x Basic module top left with manifold PCB (printed circuit board)**
 - A3b 1 x Basic module bottom left**
 - A3c 1 x Basic module top right with manifold PCB and line filter**
 - A3d 1 x Basic module bottom right**

Assembling the basic modules – two steps:

I. Setting up the basic modules

- 8 x T-nuts **M8**
- 8 x Socket head screws **M8x30**
- 8 x Washers

II. Connecting the basic modules to the control panel

- 16 x **14-stranded** flat ribbon cables to connect to the manifold PCBs marked as 0.1 - 0.4, 1.1 - 1.4, 2.1 - 2.4 and 3.1 - 3.4
- 2 x **26-stranded** flat ribbon cables to connect to the control panel (marked as A and B)
- 1 x **double-pole** power supply cable including connectors 1 and 2 in pre-assembled PVC installation channel

- ▼ **B1** **1 x Stainless steel frame cover left**
- B2** **1 x Stainless steel frame cover right** incl. control panel with power supply jack and power supply switch (connections for further equipment such as loudspeakers or headsets are available)
- B3** **2 x Stainless steel frame covers** (*top/bottom*)

Assembling the stainless steel frame covers:

- 11 x Fillister head screws **M6x10**

- ▼ **C** **Accessories** (*included in scope of delivery*)
 - C1** **1 x Power supply line (with Euro connector)**
 - C2** **1 x USB cable (A/B)**
 - C3** **1 x Adapter (power supply unit)**
 - C4** **1 x Set of Allen keys (4 mm, 5 mm and 6 mm | 0.16 inch, 0.20 inch and 0.24 inch)**
- ▼ **D** **Required tools** (*not included in scope of delivery*)
 - Stepladder
 - Spirit level
 - Measuring tape
 - Hammer drill
 - Drill bit **12 mm | 0.47 inch**
 - Wrench **17 mm | 0.67 inch**
- ▼ **E** **User manual and data-CD**

3 Assembly

ATTENTION: Before start-up a period of 1-2 hours is advised for the equipment to acclimatize. Please pay attention to condensation that might appear.

3.1 Mobile installation of the twall®Premium64 mobil

3.1.1 Storage space requirements

In order to set up the twall® a compact and even stand space of a minimum of 3 x 3 m | 118.11 x 118.11 inch is required (**fig. 3.1-1**). It must carry a weight of at least 275 kg | 43.3 stone.

At least 2 people and the following tools are required:

- ▶ Allen keys 4 mm
 - ▶ Allen keys 5 mm
 - ▶ Allen keys 6 mm
 - ▶ Stepladder
 - ▶ Spirit level
 - ▶ Measuring tape
 - ▶ Slot screwdriver 9 mm | 0.35 inch
- } included in scope of delivery

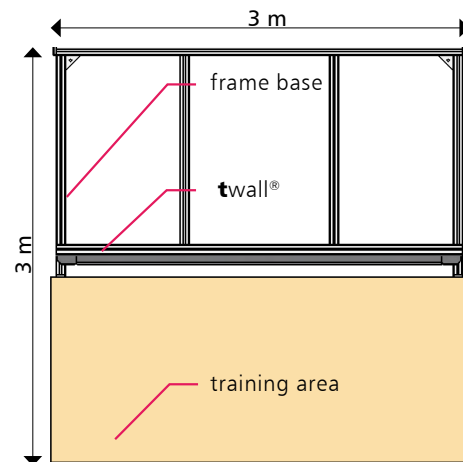

fig. 3.1-1

3.1.2 Assembly principle of the profile connectors

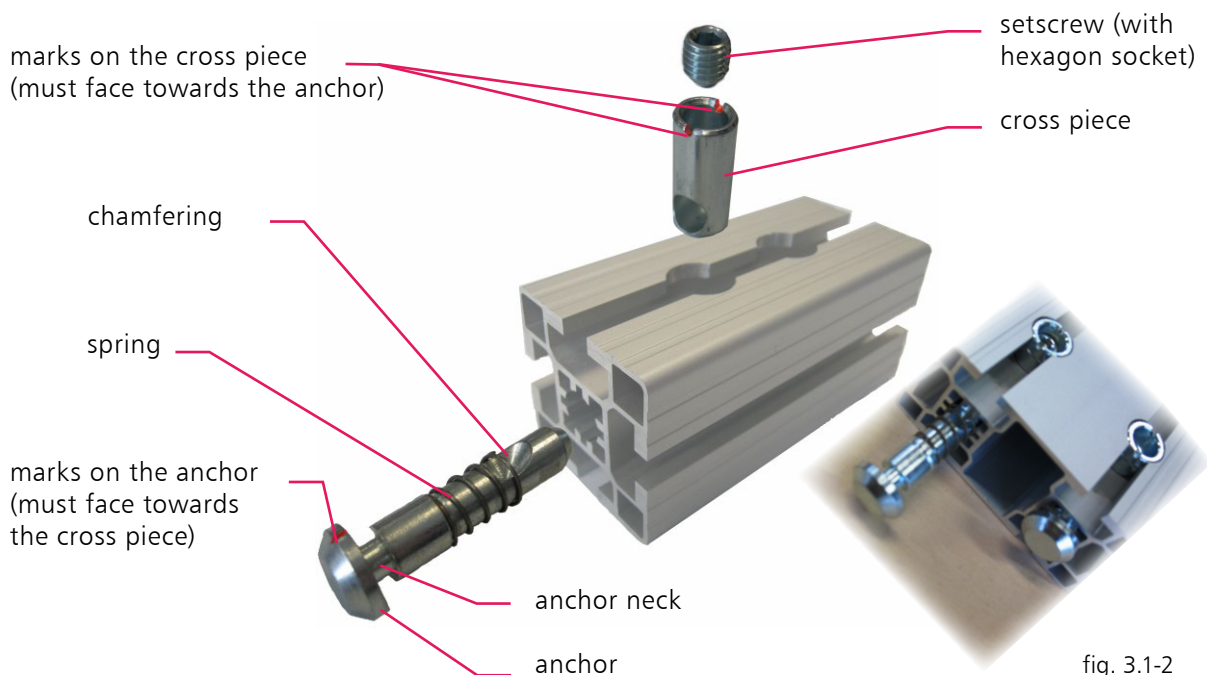

fig. 3.1-2

PLEASE NOTE: For more information, please view individual assembly steps on separate handout.

3.1.3 Assembly instructions

3.1.3.1 Assembling the frame base

1. Mounting the frame base profiles:

Step 1 Please remove the packaging material. You may use this as a protective pad during assembly to avoid components being scratched or damaged.

Step 2 Before you start putting together the frame base **A1** (*fig. 3.1-3*), please attach all the profile connectors to the provided positions at the frame base profiles first. Four (4) profile connectors should be kept for the side supports of the aluminium frame. In order to fasten the profile connectors, the chamfering should point towards the cross piece which is indicated by the mark at the anchor (*fig. 3.1-2*). The set screw will be slightly screwed into the cross piece with the corresponding Allen key. The anchor will be drawn into the profile automatically. It is important that you can still see the neck of the anchor (*fig. 3.1-4*) to be able to insert it into the lead channels at a later point (*fig. 3.1-5*). It might be the case that you need to push the anchor slightly against the cross piece while screwing it in.

Step 3 Shove the two (2) frame base profiles **A1d** into the lead channels of the frame profiles **A1a** and **A1b** (*fig. 3.1-5*). Please ensure that the cross pieces of the connectors in the frame base profiles **A1d** point inwards and the cross pieces of the connectors in the frame base profile **A1b** point outwards.

Step 4 Now shove the frame base profiles **A1c**, one to the right and to the left, into the lead channels of the frame base profile **A1a**. Align the outer edges of the profiles so they can be flushmounted. The cross pieces of the connectors should point outwards. Now tighten the profile connectors with the corresponding Allen key (ca. 25 Nm).

Step 5 Measure the distance between the frame base profiles **A1c** and **A1d**. The distance has to be 42 cm (16.54 inch) between the inner edges. Once you have fastened the frame base profiles **A1c** and **A1d** you can strongly bolt together all other profile connectors (ca. 25 Nm) (*fig. 3.1-6*).



fig. 3.1-3

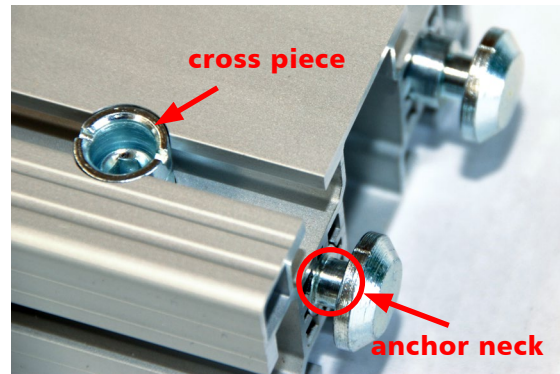

fig. 3.1-4

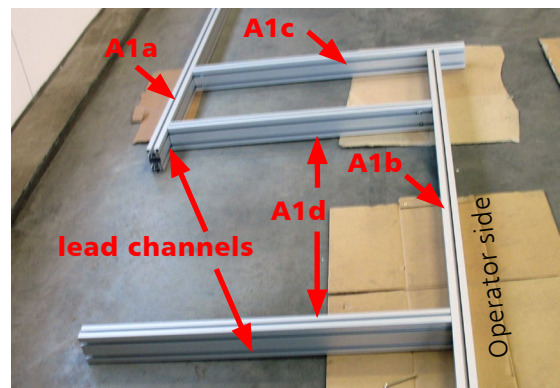

fig. 3.1-5



fig. 3.1-6

Step 6 Put the frame base in an upright position in order to attach the four (4) rubber feet to the bottom of the frame base. **(fig. 3.1-7 and 3.1-8)** The projecting profiles should point upwards. Push the rubber feet into the lower lead channels and position the adhesive feet at the outer lower edges of the frame base profiles **A1c**.



fig. 3.1-7



fig. 3.1-8

II. Attaching the profile angles to the frame base:

Step 7 The four (4) profile angles **A1e** will be fitted to the inner sides of the frame base profiles **A1c** and **A1d** **(fig. 3.1-9)**. Place the twelve (12) T-nuts **M8** in the lower lead channels of the frame base profiles A1c and A1d (3 T-nuts per side and angle respectively). Insert the T-nuts by half-twisting them into the lead channels with the swivel ball ahead **(fig. 3.1-10 and 3.1-11)**.

Roughly estimate the concentric position of the profile angles and align the T-nuts appropriately. Since the weights will be placed on the profile angles, the angle should be attached with the surface pointing towards you. Screw on the profile angles using the T-nuts and the twelve (12) fillister head screws **M8x16** with flange (3 per angle).



fig. 3.1-9



fig. 3.1-10



fig. 3.1-11

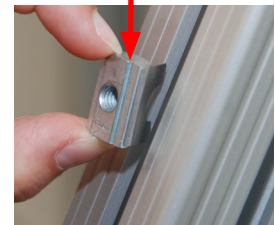

fig. 3.1-11

III. Fastening the joints to the angles braces:

Step 8 At first, the four (4) threaded inserts will be screwed into the open ends of the angles braces (**A1g**) using a **9 mm | 0.35 inch** slot screwdriver. In order to attach the joints **A1f** to the angles braces, put two (2) adjusting blocks opposite of each other into the provided holes. It is very important to insert the adjusting blocks into the holes at the sides where the arms of the joints are located and that the number 8 on top of the adjusting blocks points outwards. **(fig. 3.1-12 and fig. 3.1-13)**. You will find that the adjusting blocks marked with number 8 will fit exactly into the lead channels. Now position the joints at the ends of the angles braces and bolt them together using the four (4) socket head screws **M8x25**, the washers and the corresponding Allen key. **(fig. 3.1-14)**.

Please take care to mount all joints to the angles braces facing the same direction. To simplify the process, we would recommend attaching the angles braces to the frame base once having assembled the aluminium frame.

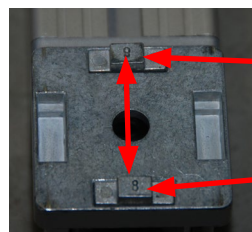

fig. 3.1-12

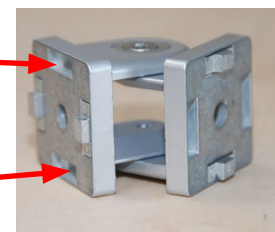

fig. 3.1-13

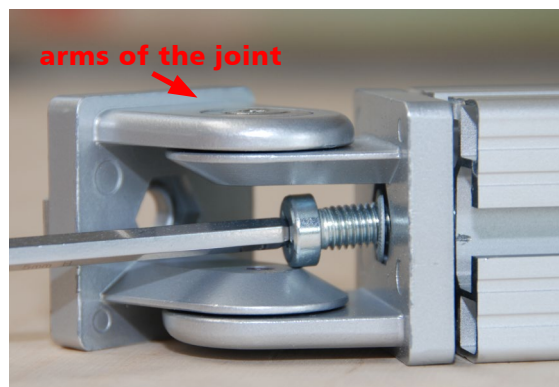

fig. 3.1-14

3.1.3.2 Assembling the aluminium frame

1. Mounting the frame profiles:

The aluminium profile serves as the frame of the **twall®Premium64**, in order to be installed freestanding. (**fig. 3.1-15**).

Step ⑨ Place the frame base **A1** with the rubber feet at the lower side the way that the projecting profiles **A1c** are facing you (**fig. 3.1-15**). To ensure the **twall®** is firm and stable a compact and even stand space is required. Before you start putting together the aluminium frame, please attach all the profile connectors to the provided positions at the frame profiles. Four (4) profile connectors were kept earlier (see step 2) to be fastened to the side supports of the aluminium frame. In order to fasten the profile connectors, the chamfering should point towards the cross piece which is indicated by the mark at the anchor (**fig. 3.1-2**). In order to fasten the profile connectors, the chamfering should point towards the cross piece which is indicated by the mark at the anchor (**fig. 3.1-16**). It might be the case that you need to push the anchor slightly against the cross piece while screwing it in.

Step ⑩ Shove the side supports **A2a** from the front into the lead channels of the frame base (**fig. 3.1-16**). Please make sure that the cross pieces of the profile connectors at the side supports point outwards. The side supports have to be on the same level as the frame base profile (**fig. 3.1-17**). Now tighten the profile connectors with the corresponding Allen key (ca. 25Nm). Finally, attach the four (4) black cover caps at the ends of the frame base profiles **A1c** and **A1a**.

Step ⑪ Insert a long frame profile **A2c** into the front lead channel between the side supports, move it down to the frame base and bolt it together with the profile connectors (**fig. 3.1-18**).

The cross pieces of the profile connectors should point backwards.



fig. 3.1-15

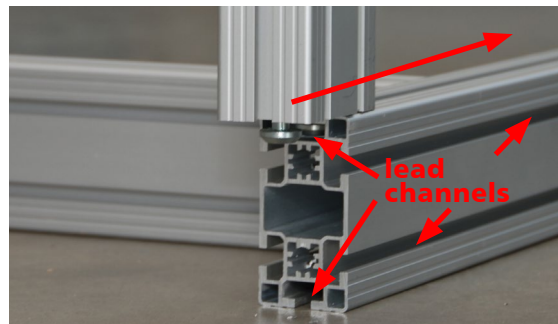

fig. 3.1-16

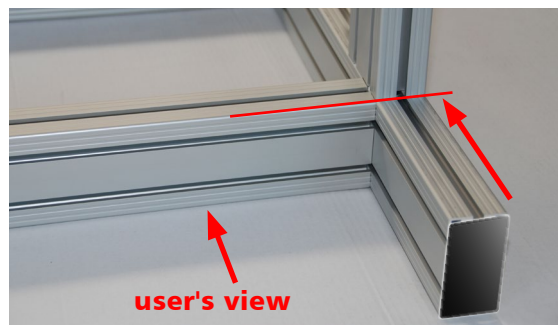

fig. 3.1-17



fig. 3.1-18



Step ⑫ Shove the shield **A2b** into the front lead channel between the side supports down to the long frame profile **A2c**.
(fig. 3.1-19).

The shield (8 mm | 0.32 inch) should click exactly into the lead channel of the frame profile.

Step ⑬ Then insert another long frame profile **A2c** into the front lead channel between the side supports and move it down to the shield **A2b** which should click into the lead channel at the top.

The cross pieces of the profile connectors should point backwards again. Please tighten the profile connectors (ca. 25Nm).



fig. 3.1-19

II. Attaching the profile angles to the frame profiles:

Step ⑭: In order to attach the profile angles **A2e**, you will need sixteen (16) fillister head screws with flange **M6x14** (2 per angle) and sixteen (16) T-nuts **M6**. Measure the long frame profile **A2c** which you have just mounted to the shield. There are **930 mm | 38.07 inch** from to inner edge of the side supports to the middle of the screws the profile angles will be screwed on with. Now place two (2) Tnuts in the upper lead channel of the long frame profile. Insert the T-nuts by half-twisting them into the lead channels with the swivel ball ahead and align them appropriately (fig. 3.1-20). Now insert two (2) T-nuts into the lead channels of the short frame profile **A2d**, 1 x at the bottom left and 1 x at the bottom right. There are **967 mm | 38.07 inch** from the inner edge of the side supports to the middle of the lead channel. Place the short frame profile **A2d** in the middle of the long frame profile **A2c** and attach the profile angles **A2e**, one to each side using the fillister head screws with flange (fig. 3.1-21). Tighten it properly with the corresponding Allen key.



fig. 3.1-20



fig. 3.1-21

Step ⑮ Insert two (2) T-nuts into the just assembled short frame profile again, this time 1 x at the top left and 1 x at the top right. Afterwards shove the long frame profile **A2c** with the pre-assembled **PVC installation channel** into the front lead channel between the side supports, move it down until it seats on the vertically placed short frame profile. The PVC installation channel should point backwards. Now insert two (2) T-nuts into the lower leading channel of the long frame profile and align them as follows: From each side measure a distance of

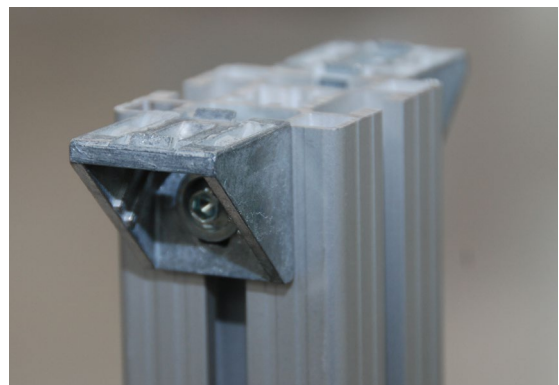

fig. 3.1-22

930 mm | 36.61 inch from the inner edge of the side supports to the middle of the screws the profile angles will be screwed on with. Attach two (2) profile angles **A2e** to the long and the short frame profiles again (**fig. 3.1-22 and fig. 3.1-23**). Afterwards tighten the profile connectors of the long frame profile **A2c** with a corresponding Allen key (ca. 25Nm).



Please pay attention to a horizontal alignment of the frame profile so that a correct placement of the basic modules is ensured (spirit level).



fig. 3.1-23

Step 16 Please go back to step **14** and step **15** and repeat the procedure with the remaining frame profiles **A2c** and **A2d**.

III. Fastening the angles braces:

Now you need to attach the angles braces **A1g** to the rear part of the frame base **A1** and the rear side of the side supports **A2a** (**fig. 3.1-24**).

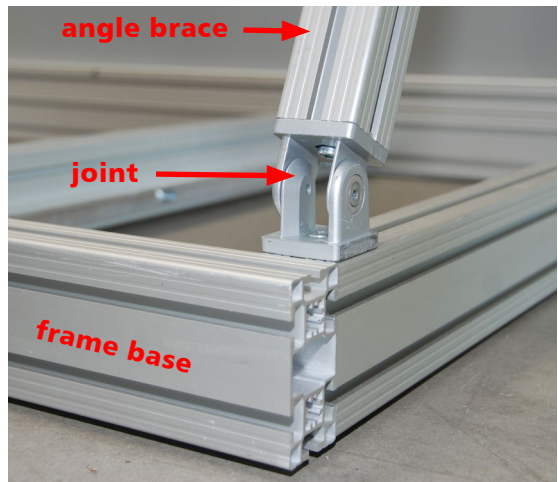

fig. 3.1-24

Step 17 Place a T-nut into the lead channels at each side of the frame base profiles **A1c**. Put two (2) adjusting blocks opposite of each other into the provided holes of the joints.



This time it is very important to insert the adjusting blocks into the holes at the open sides of the joints (not the sides where the arms are located) (**fig. 3.1-25**). The number 8 on top of the adjusting blocks have to point outwards again (**fig. 3.1-26**).

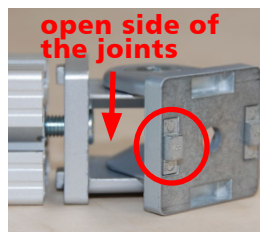

fig. 3.1-25

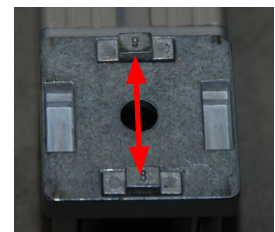

fig. 3.1-26

They will fit exactly into the lead channels. Now position the joints at the frame base profiles **A1c**. and bolt them together using two (2) socket head screws **M8x16**, two (2) washers and the corresponding Allen key.



To make the assembly a bit easier for you, we would advise to place the other ends of the angle braces backwards.

Step 18 In order to fit the other ends of the angles braces **A1g** to the side supports (**fig. 3.1-27**) you need to insert two (2) T-nuts **M8** into the lead channels at the rear side of the side supports (one Tnut per side) and position the adjusting blocks, as described above, in the remaining holes of the joints. Now bolt the joints at the angles braces to the side supports using the remaining socket head screws **M8x16** and the washers and tighten them properly.



fig. 3.1-27

Step 19 Place the weights **A4** at the rear side of the frame base (**fig. 3.1-28**). Please be aware of the industrial safety regulations (20 kg | 44 lbs per weight).

Step 20 Finally, put the two (2) black cover caps on the top ends of the side supports and press the four (4) grey PVC combination profiles into the outward lead channels of the side supports (above the cross pieces of the profile connectors, 2 x at the right side and 2 x at the left side).

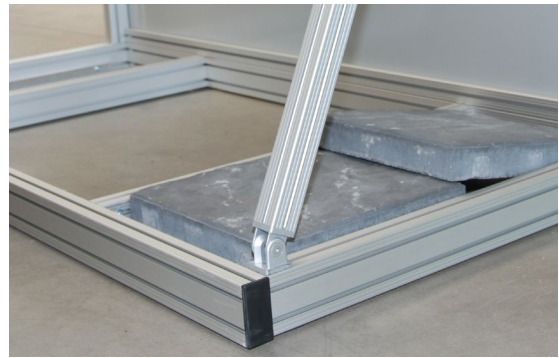

fig. 3.1-28

PLEASE NOTE: Once having finished the assembly of the aluminium frame, please check whether all profile connectors at the frame base and the aluminium frame are bolted together strongly (ca. 25Nm).

3.1.3.3 Assembling the basic modules

If you have done all these steps, it must look like in **fig. 3.1-29**. Now you can start with setting up the basic modules.

1. Setting up the basic modules:

Step 21 Before you start mounting the basic modules, please insert all eight (8) T-nuts **M8** required into the front lead channels of the side supports.



fig. 3.1-29

Step 22 The basic modules **A3a** to **A3d** are marked bottom right (UR), bottom left (UL), top right (OR) and top left (OL). Insert the two lower basic modules into the frame construction using the z-profiled plates attached to the rear of each module (**fig. 3.1-30**). The basic modules will be fixed with two (2) provided socket head screws **M8x30** and two (2) washers for each module.

Step 23 Please go back to step 22 and repeat the procedure with the upper basic modules.

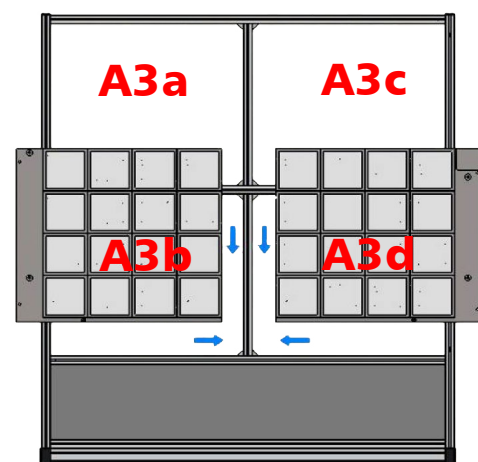

fig. 3.1-30

II. Connecting the basic modules to the control panel:

Step 24 You can find four (4) **14-stranded** flat ribbon cables at each basic module to connect them to the manifold PCBs (**fig. 3.1-32 and 3.1-33**). The cables are marked as 0.1 - 0.4, 1.1 - 1.4, 2.1 - 2.4 and 3.1 - 3.4 as well as the appropriate plug number. Now put the flat ribbon cables on the manifold PCBs. The PCB for the two (2) right upper basic modules can be found at the right upper basic module, the PCB for the two (2) left upper basic modules are located at the left upper basic module (**fig. 3.1-31**).

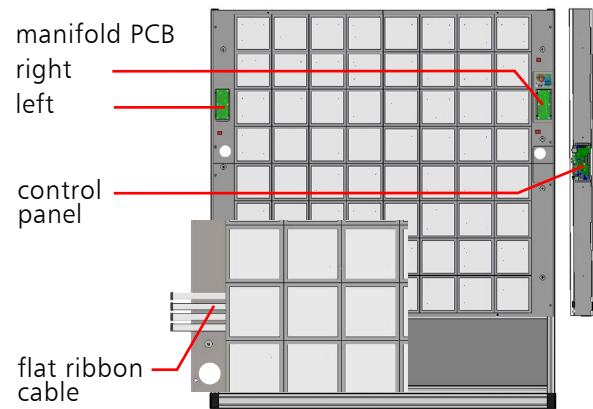

fig. 3.1-31

PLEASE NOTE: Connectors and cables are numbered and have to be connected in that exact order!

Step 25: Then connect the manifold PCBs to the control panel using the two (2) **26-stranded** flat ribbon cables. The broad flat ribbon cables are marked as "A" and "B" as well as the plug number "X2". Connect the plug of flat ribbon cable "A" to the plug "X2" of the manifold PCB at the right upper basic module (**fig. 3.1-34**). The flat ribbon cable "B" has to be laid through the prepared hole of the left upper **module (OL)** to the rear side. Then it needs to be laid through the PVC installation channel at the back and through the hole again of the right upper **module (OR)** to the front in order to be connected to the control panel. Please be aware that you need to follow these instructions only if it has not been delivered that way. Now connect the flat ribbon cable "B" to the plug "X2" of the manifold PCB at the left upper basic module.

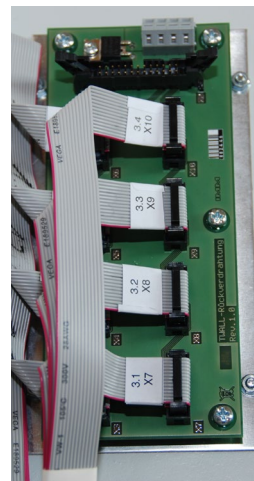

fig. 3.1-32

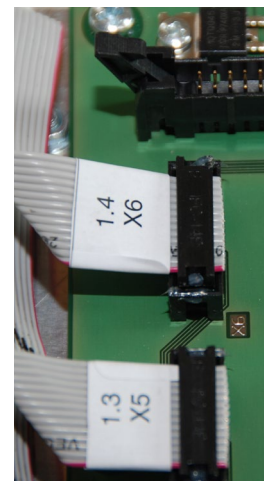

fig. 3.1-33

Step 26: Now you can connect the plugs of the flat ribbon cables "A" and "B" to the control panel in the right stainless steel frame cover (**fig. 3.1-35**).

Please be aware that the flat ribbon cable "B" must be connected to the **left upper** plug of the control panel and the flat ribbon cable "A" to the **left lower** plug.

For the use of a display, printer or other output devices it is necessary to connect the 9-stranded ribbon cable with the plug "C" to the controller on the left side down.

The controller consists of one further plug, where you can connect your peripheral devices.

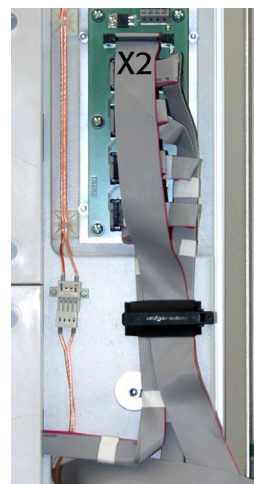

fig. 3.1-34

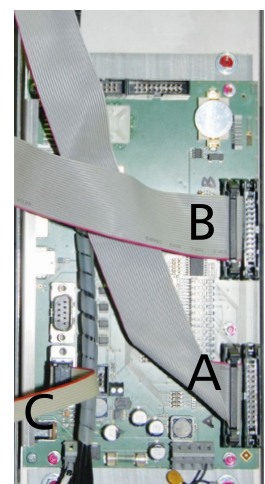

fig. 3.1-35

Step 27: Now connect the power supply for the basic modules. For connector positions please see **fig. 3.1-36**. At first, connect connector 1 (upper left basic module) to connector 2 (upper right basic module below the manifold PCB). Following, connect connector 3 (upper right basic module above the line filter) to the control panel in the stainless steel frame cover **B2**.

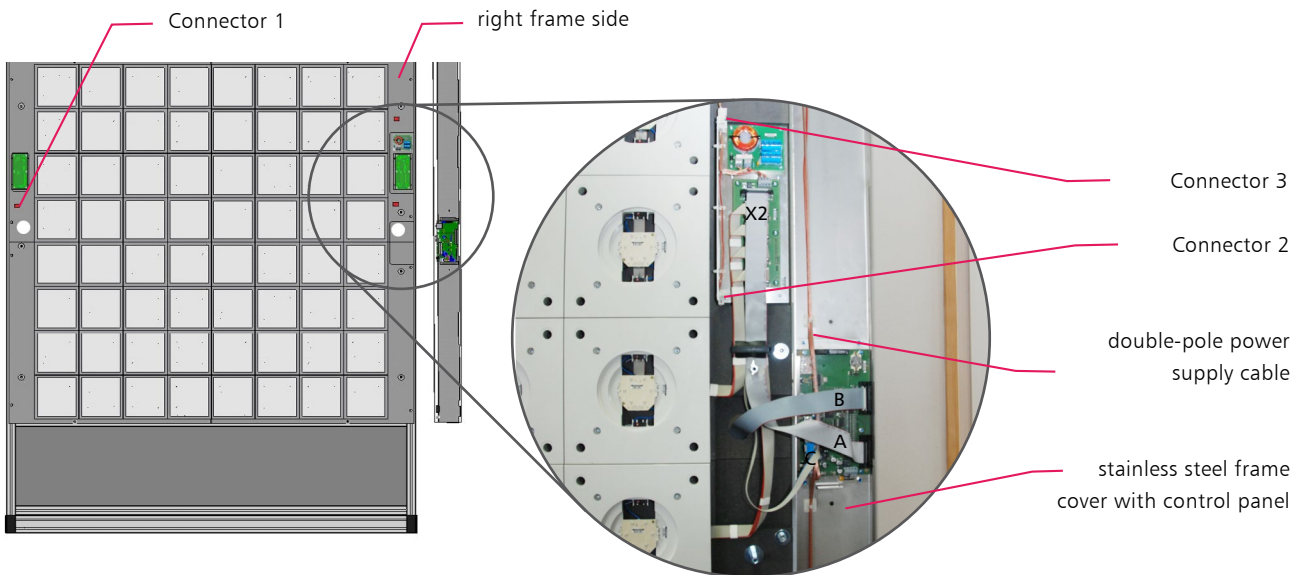

fig. 3.1-36

PLEASE NOTE: Please keep in mind that the correct polarity has to be considered as it is mechanically coded. Please avoid any violence. Please make sure to handle the cables very carefully. Do not pull or twist them, especially not close to the connectors. Furthermore, please use the correct cable slots of the stainless steels frame covers to avoid that any cables will be damaged.

Step 28 Screw the lateral stainless steel frame covers **B1 and B2** and the upper / lower stainless steel frame cover **B3** respectively to the threaded bolts attached to the basic modules using the eleven (11) fillister head screws **M6x10** provided and the corresponding Allen key (**fig. 3.1-37**). Please remove the protection film before you assemble the frame cover.

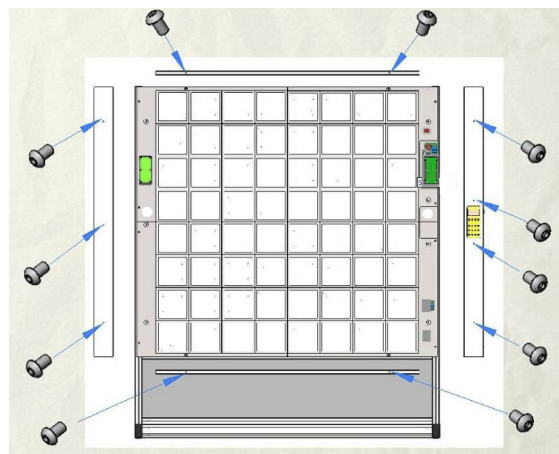

fig. 3.1-37

Step 29 Putting into operation: Plug the 24V barrel connector of the provided adapter **C3** into the 24V jack of the **twall®**. The jack and the switch can be found at the right stainless steel frame cover. Now connect the adapter to the power supply line and plug it into a 200V/ 10A socket and switch on the **twall®** (**fig. 3.1-38**). All lights will flash up for a short moment and the **twall®** is ready to operate.

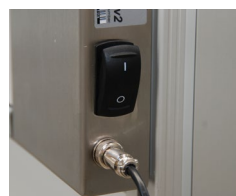

fig. 3.1-38

3.2 Stationary installation of the twall®Premium64

3.2.1 Storage space requirements

The wall the device will be assembled to must have a sufficient solidity and should be suitable to use the provided dowels. Plaster-board walls have to be covered at least twice. The safe fastening of the device should be checked on a regular basis (**fig. 3.2-1 and 3.2-2**).

In order to assemble the twall®, you will require at least 2 individuals and the following tools:

- ▶ Allen keys (included in scope of delivery)
- ▶ Stepladder
- ▶ Spirit level
- ▶ Measuring tape
- ▶ Hammer drill
- ▶ Drill bit (size 12 mm | 0.47 inch)
- ▶ Wrench (size 17 mm | 0.67 inch)

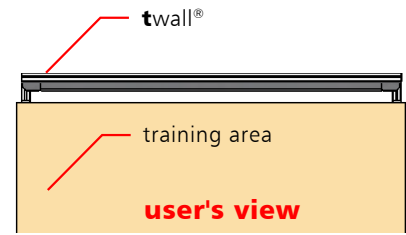

fig. 3.2-1

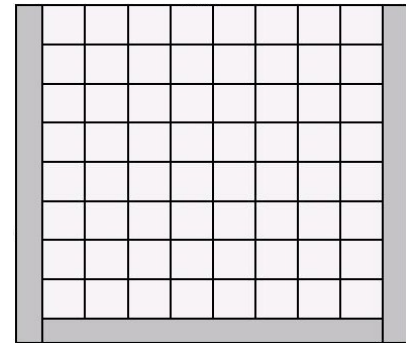

fig. 3.2-2

3.2.2 Assembly instructions

3.2.2.1 Assembling the aluminium frame

1. Mounting the frame profiles::

Step ① Please remove the packaging material. You can use it as a pad during the assembly to avoid that the components are scratched or damaged.

Step ② Before you start putting together the aluminium frame **A2** (**fig. 3.2-3**) please attach the eight (8) profile connectors to the provided positions at the long frame profiles **A2c** first.

In order to fasten the profile connectors, the chamfering should point towards the cross piece which is indicated by the mark at the anchor (3.1-2, assembly principle of the profile connectors). The set screw will be slightly screwed into the cross piece with the corresponding Allen key. The anchor will be drawn into the profile automatically.

It is important that you can still see the neck of the anchor (**fig. 3.2-4**) to be able to insert it into the lead channels at a later point. It might be the case that you need to push the anchor slightly against the cross piece while screwing it in.



fig. 3.2-3

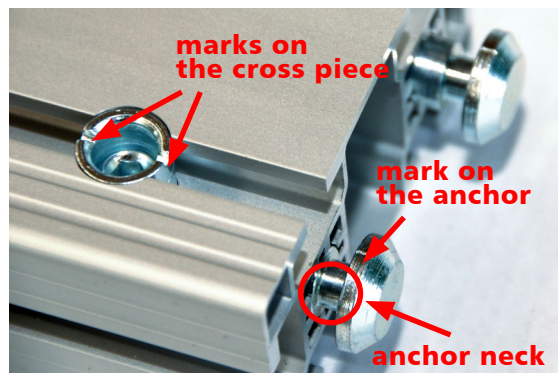

fig. 3.2-4

PLEASE NOTE: In order to assemble the aluminium frame, place the construction on the floor. The side the basic modules will be mounted to at a later point (side of the training area) should face the floor. Therefore, the cross pieces of the profile connectors should point upwards.

Step ③ Insert a long frame profile **A2c** into the lower lead channel (towards the floor) between the side supports **A2a**.

The ends of the frame profile and the side supports have to be on the same level and need to be flush-mounted (**fig. 3.2-5**). The cross pieces of the profile connectors should point upwards (towards you). Now tighten the profile connectors with the corresponding Allen key (ca. 25Nm).

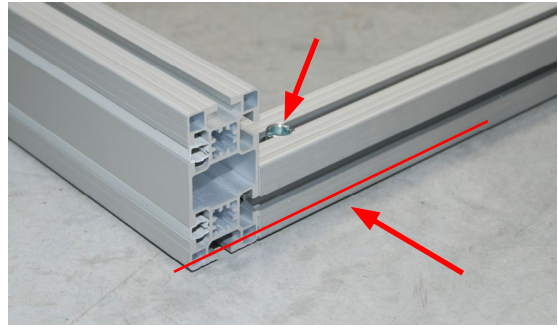

fig. 3.2-5

Step ④ Shove the shield **A2b** into the lower lead channel between the side supports. The shield (8 mm | 0.32 inch) should click exactly into the lead channel of the long frame profiles **A2c** which you have just assembled.

Step ⑤ Then insert another long frame profile **A2c** into the lower lead channel between the side supports and move it towards the shield which should click exactly into the lead channel of the frame profile (**fig. 3.2-6**).

The cross pieces of the profile connectors should point upwards (towards you). Please tighten the profile connectors (ca. 25Nm).



fig. 3.2-6

II. Attaching the profile angles to the frame profiles:

Step ⑥ In order to attach the profile angles **A2e**, you will need sixteen (16) fillister head screws with flange **M6x14** (2 per angle) and sixteen (16) T-nuts **M6**. Measure the long frame profile **A2c** which you have just mounted to the shield. There are **930 mm | 36.61 inch** from to inner edge of the side supports to the middle of the screws the profile angles will be screwed on with. Now place two (2) T-nuts in the lateral lead channel of the long frame profile (the shield just clicked into the lead channel at the other side of the frame profile). Insert the T-nuts by half-twisting them into the lead channels with the swivel ball ahead and align them appropriately (**fig. 3.2-7**).

Now insert two (2) T-nuts into the lead channels of the short frame profile **A2d**, 1 x at the bottom left and 1 x at the bottom right. There are 967 mm | 38.07 inch from the inner edge of the side supports to the middle of the lead channel.

Place the short frame profile **A2d** in the middle of the long frame profile **A2c** and attach the profile angles **A2e** A2e, one to each side using the fillister head screws with flange (**fig. 3.2-8**). Tighten it properly with the corresponding Allen key.

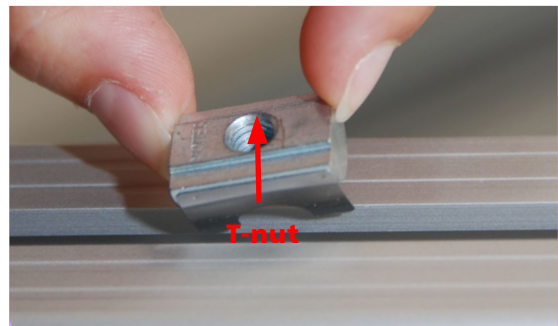

fig. 3.2-7

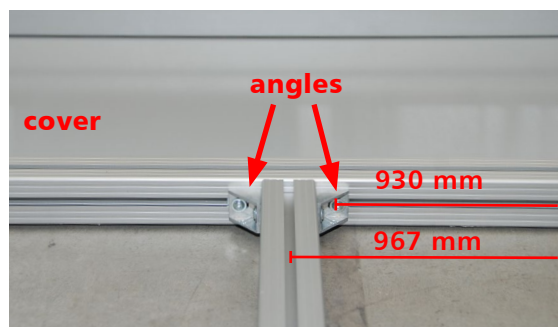

fig. 3.2-8

Step 7 Insert two (2) T-nuts into the just assembled short frame profile again, this time 1 x at the top left and 1 x at the top right. Afterwards shove the long frame profile **A2c** with the pre-assembled PVC installation channel into the lower lead channel between the side supports, move it until it seats on the short frame profile.

The PVC installation channel should point upwards (towards you). Now insert two (2) T-nuts into the leading channel of the long frame profile and align them as follows: From each side measure a distance of **930 mm | 36.61 inch** from the inner edge of the side supports to the middle of the screws the profile angles will be screwed on with. Attach two (2) profile angles **A2e** to the long and the short frame profiles again (*fig. 3.2-9*). Afterwards tighten the profile connectors of the long frame profile **A2c** with a corresponding Allen key (ca. 25Nm).

Please pay attention to a horizontal alignment of the frame profile so that a correct placement of the basic modules is ensured (spirit level).

Step 8 Please go back to step **6** and step **7** and repeat the procedure with the remaining frame profiles **A2c** and **A2d**.

Please make sure that the ends of the last frame profile **A2c** and the side supports **A2a** are on the same level and will be flush-mounted (*fig. 3.2-10*). Also, please check again if you have strongly tightened all the profile connectors (ca. 25Nm).

Step 9 Finally, put the two (2) black cover caps on the top ends of the side supports **A2a** (*fig. 3.2-11*) and press the four (4) grey PVC combination profiles into the outward lead channels of the side supports (above the cross pieces of the profile connectors, 2 x at the right side and 2 x at the left side).



fig. 3.2-9



fig. 3.2-10

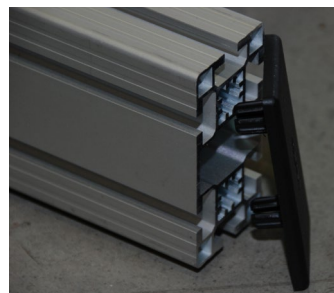

fig. 3.2-11

III. Attaching the angles for wall fastening:

Step ⑩ In order to attach the angles **A2f** to the side supports (**fig. 3.2-12**), please take the following measurements:

Distances:	twall®Premium64 stationary
From the floor to the lower edge of the lower angles (close to the shield):	635 mm 25 inch
From the lower edge of the lower angles to the upper edge of the upper angle (close to the cover caps):	1415 mm 55.71 inch

PLEASE NOTE: Basically, the height of the angles can vary especially if there any obstacles in the wall the device will be assembled to such as trusses or pipelines.

Step ⑪ Insert eight (8) T-nuts **M8** into the upper lead channels at the inside of the side supports and align them according to the measurements taken (4 T-nuts per side of which 2 are per measurement).

Step ⑫ Now mount the angles **A2f** to the upper lead channels at the inside of the side supports using two (2) Verbus-Rippscrews **M8x20** per angles (**fig. 3.2-12**). Please tighten the screws appropriately (ca. 25 Nm).



▲ fig. 3.2-12 ▼

IV. Setting up the aluminium frame:

Step ⑬ To be able to assemble the aluminium frame you have to prepare drill holes in the wall the device will be installed to. You will require a hammer drill, a drill bit (size **12 mm | 0.47 inch**) and protective work equipment:

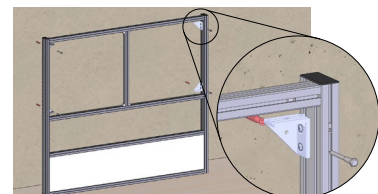

Distances on the wall	twall®Premium64 stationary
From the floor to the middle of the lower drill hole:	660 mm 25.98 inch
From the middle of the lower drill hole to the middle of the upper drill hole:	1365 mm 53.74 inch
The horizontal distance from hole middle to hole middle:	1883 mm 74.13 inch

PLEASE NOTE: Plasterboard walls have to be covered at least twice. The safe fastening of the device should be checked on a regular basis.

Step ⑭ Place the provided plastic dowels 10x70 in the drill holes at the wall.

Step ⑥ Lift the aluminium frame **A2** (fig. 3.2-13) at the side where the cover caps are located and set it up. The lower part should be placed against the wall. Now mount the aluminium frame to the wall by screwing the four (4) hexagon head wood screws 10x70 into the pre-assembled plastic dowels and tighten them properly using the wrench (size **17 mm | 0.67 inch**).



fig. 3.2-13

3.2.2.2 Assembling the basic modules

I. Setting up the basic modules: (fig. 3.2-14)

In order to set up the basic modules, please see the assembly instructions of the twall®Premium64 mobile (chapter 3.1.3.3).

II. Connecting the basic modules to the control panel:

In order to connect the basic modules to the control panel, please see the assembly instructions of the twall®Premium64 mobile (chapter 3.1.3.3).

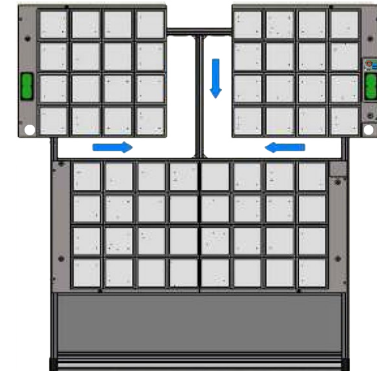

fig. 3.2-14

4 Maintenance

Every sports device is constantly exposed to dust and sweat. Same applies to the twall®. During frequent use some soil deposit may occur on the surface of the touch elements. To ensure a long life cycle and a maintained appearance please clean the touch elements and the frame at least once a month. In case of more frequent use we recommend twice a month. Please use a soft, lint-free and dry cloth. In case of heavy soiling, the cloth can be used in combination with a mild detergent or disinfectant. At the same time please examine the mechanical integrity of the PVC-covers (broken locking lugs).

PLEASE NOTE: Never use dissolver or gas as this may damage the touch elements.

5 Troubleshooting

Potential errors/malfunction sources

- ▶ Check if a sufficient power supply is available. Please pay attention that the power supply unit is correctly connected to the twall® and the socket.
- ▶ In case of interruptions, please check if enough space is provided between the sports device and components that generate strong magnetic fields such as loudspeakers or microwaves.
- ▶ Should any liquids or external items get into the inside of the twall® disconnect the twall® from the power supply and contact your service provider.

PLEASE NOTE: Additional help will you get from our twall® online support on "www.twall.de". In the download area (see page 22, Step 1 & 2) you can find the relevant documents for specific troubleshooting and correction of errors as well as complaints.

6 Technical specifications

6.1 Data sheet twall®Premium64 mobile and stationary

- ▶ Autarkic, multicoloured interactive indoor training device twall®Premium64
- ▶ Integrated control panel, 10 preinstalled training programs
- ▶ Graphic program surface to create favoured programs
- ▶ 8 x 8 touch elements
- ▶ Active training area
in mm | inch (H x W):1760 x 1760 mm | 70 x 70 inch)
- ▶ Dimension of whole device
(mobile) in mm | inch (H x W x D): 2350 x 2030 x 1106 | 92.5 x 79.9 x 43.5
- ▶ Dimension of whole device
(stationary): (H x B x T): (2300 x 2030 x 138) mm
- ▶ Weight in kg | lbs (mobile) approx 231 | 509.3
- ▶ Weight in kg (stationary) approx 116 | 255.7
- ▶ Up to 7 fluorescent colors (red, green, blue and mixed colours)Rahmen Edelstahl
- ▶ Frame: stainless steel
- ▶ Touch elements: plastic, color translucent white
- ▶ Power input: 120 W
- ▶ Power supply: 24 V (power supply jack and switch)
- ▶ Anschlussbuchse für Stromversorgung und Schalter
- ▶ Freestanding (mobile) or wall fastening (stationary)
- ▶ Maintenance intervals:
 - semi-annual and according to the terms of lease respectively (mobile)
 - once a year (stationary)
- ▶ Guarantee 1 year

6.2 Data sheet – Accessories

- ▶ Power supply line (with Euro connector)
- ▶ USB cable (A/B)
- ▶ AC adapter (power supply unit) with barrel connector (**fig. 6.2-1**)
 - AC Adapter
 - Primary 90-264 V AC; 47-63 Hz
 - Secondary 24 V DC; 5 A
 - Dimensions (h x w x d in inch): 1.38 x 2.44 x 6.69
 - Weight (in g): approx. 530g
 - Euro connector
 - Barrel connector
(**fig. 6.2-2 and fig. 6.2-3**)
 - Pin 1 and Pin 2 + 24 V
 - Pin 3 and Pin 4 - 0 V



fig. 6.2-1



fig. 6.2-2

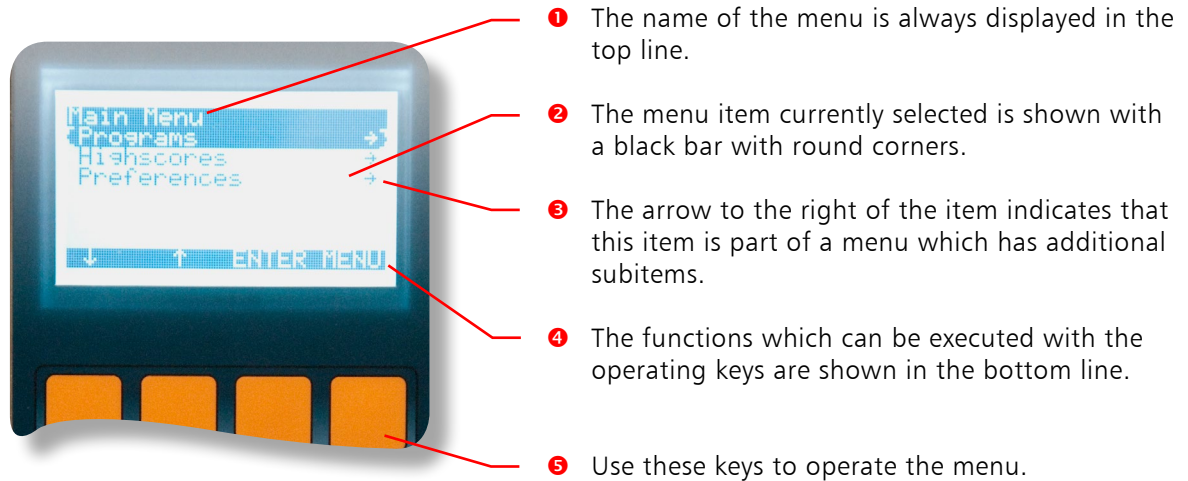

fig. 6.2-3

Software Documentation

7 Operating the twall® without a computer

Using the control unit integrated in the twall®, the twall® can be fully operated without using a computer. To this end, a menu is shown on the display which can be operated using the four orange keys beneath the display.



When navigating the main menu and its submenus, the functions for the operating keys are assigned as follows:

- ▶ The [arrow down] key selects the menu item underneath the one currently selected.
- ▶ The [arrow up] key selects the menu item above the one currently selected.
- ▶ The [ENTER] key accesses the selected submenu or activates the selected menu item.
- ▶ The [MENU] key exits the current menu.

When activating certain menu items, the assignment of the operating keys changes.

7.1 Executing twall® Programmes

In order to execute a twall® Programmes by menu, select the menu item "Programmes" in the main menu and confirm this with [ENTER]. You are now in the submenu "programme". The Programmes installed on the twall® are displayed. Select the desired programme using the arrow keys and confirm with [ENTER] to start the programme. The status of the programme is now shown on the display.

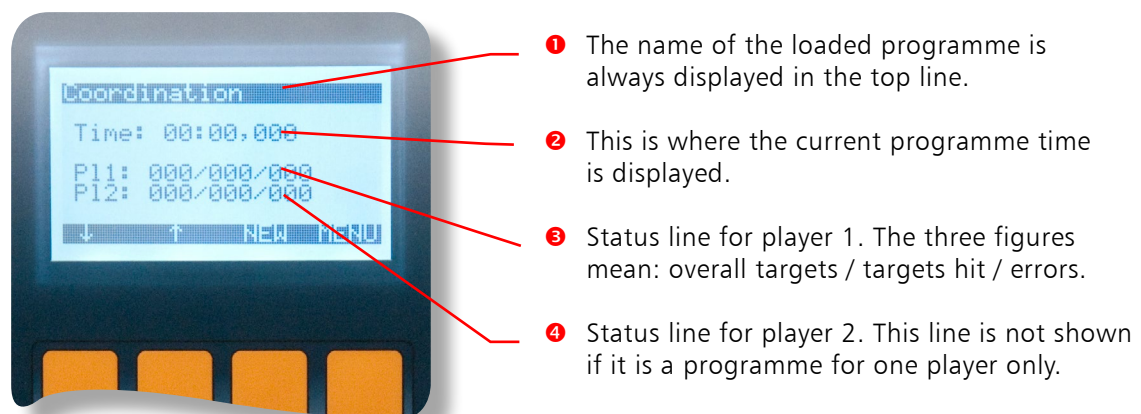

The layout of the operating keys is largely identical. The [ENTER] key is replaced in this screen by the [NEW] key with which the programmes can be restarted. The arrow keys load the next and/or previous Programmesme in the list of twall® Programmes.

The time starts to run as soon as the first touch pad on the twall® is pressed. The end of the programme is generally indicated by the brief flashing of all the touch pad.

7.2 Viewing high scores

Viewing high scores works in a similar way to implementing programmess. In the main menu, select the menu item "High scores" with [ENTER]. The "High scores" menu immediately opens, in which a list of the installed programmess is displayed. In order to display the high scores for a specific programme, select the programme using the arrow keys and then press [ENTER] to confirm. You can now navigate through the high score list using the arrow keys. A high score is always shown on a screen page.

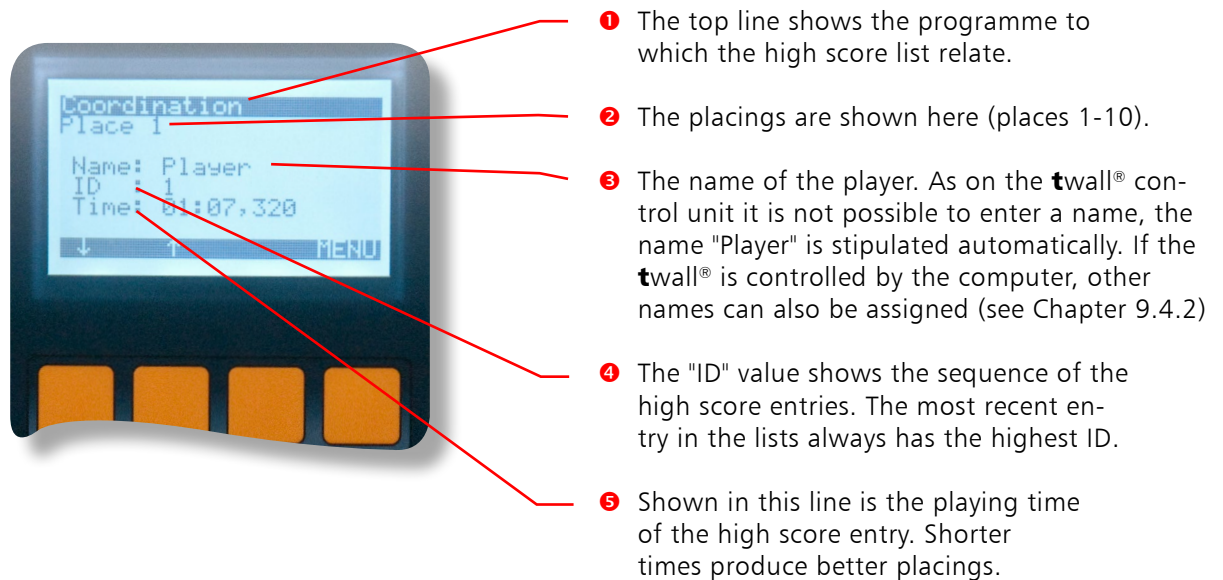

7.3 Settings

The "Settings" menu contains the item "Version info" under which the following information regarding the twall® can be accessed:

- ▶ Type of twall® (exact model designation)
- ▶ Hardware version
- ▶ Software version

NOTE: Always quote this information when sending a service inquiry to IMM.

8 Operating the twall® with a computer

The twall® is fully operational without a computer, using the integrated control unit. However, certain actions, such as creating a new programme, require the use of software. The following chapter describes how this is installed and what steps are necessary for its use.

System requirements of the PC:

- ▶ Operation systems Windows 2000/XP/Vista/7
- ▶ Microsoft .Net Runtime 2.0 (included on software-CD)
- ▶ Processor speed min. 1.0 GHz
- ▶ USB Interface
- ▶ Screen resolution: 1024*768
- ▶ 50 MByte free HDD space
- ▶ keyboard/ mouse

NOTE: The twall® drivers/software and firmware are constantly being improved. The current version at any given time can be downloaded in the download area at www.twall.de. For this you need the serial number of your twall® which can be found on left side of the stainless steel frame part.

8.1 Connecting to the computer

The twall® is connected to the computer using USB. For this you need the USB cable **C2** (included in the product contents). Insert the square plug into the corresponding socket into the twall® and the flat USB connector on the computer.

When connecting the twall® to the computer for the first time, Windows will recognise this as a new device. You must now install the driver. To do this, insert the software CD into your CD/DVD drive. You need administrator rights on your computer for installation. The following five steps describe the driver installation under Microsoft Windows XP® and Microsoft Vista®.

8.2 Driver installation

8.2.1 Driver installation under Microsoft Windows XP®



- 1 The first step of the installation is to select "No, not this time" in answer to whether the driver is to be searched for using Windows Update.
- 2 Select "Install software automatically (recommended)". The CD will automatically search for the driver.
- 3 If the required driver file "usbser.sys" is not found on your computer, you must first of all indicate its storage location yourself. The file is located on the CD in the folder entitled "Driver\winxp" or "Driver\win2k". Select the file in the "winxp" folder if you are using Windows XP or the file in the "win2k" if you are using Windows 2000®.



4 In this dialogue box select "Continue installation".



5 The installation has now completed successfully. You can now install and use the twall® software.

6 If the twall® is connected to another USB slot, the driver is installed again. This happens automatically however. Administrator rights are required even so.

8.2.2 Driver installation under Microsoft Windows Vista®

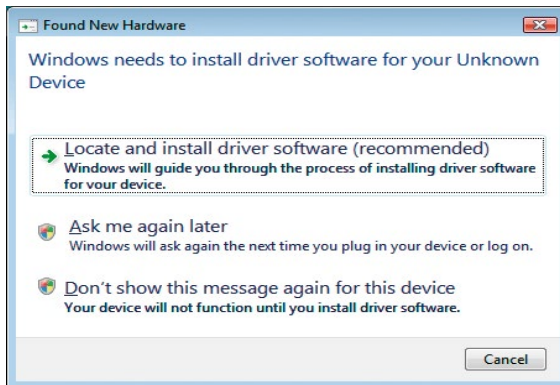

1 The first stage of the installation is to select "Search for and install driver (recommended)".

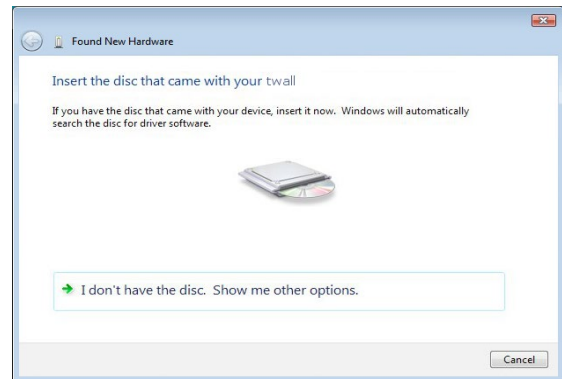

2 If this dialogue does not appear, select under the green arrow "...Show other options".

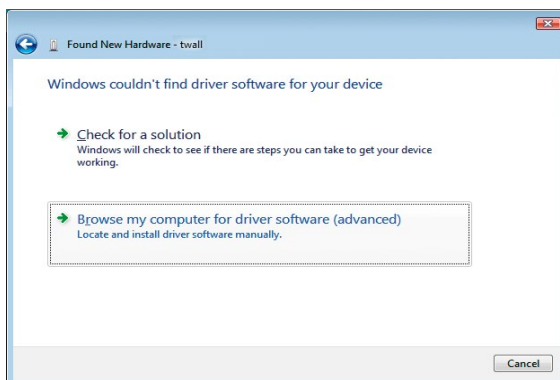

3 Select "Search for driver software on the computer (expanded)".

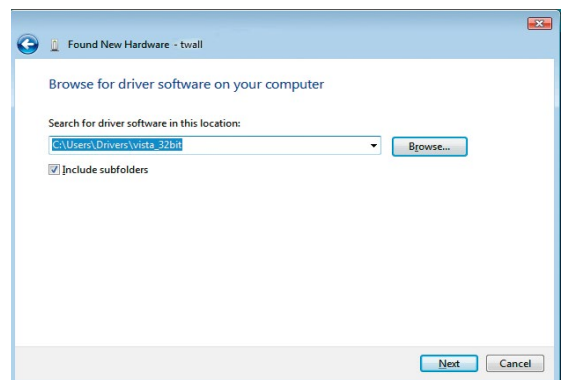

4 Click on the key [Search] and select the directory:Driver\vista_32bit on the data CD. Then click on [Continue].

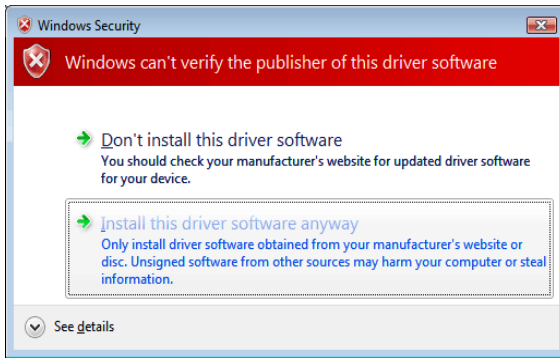

5 Select "Install this driver software anyway".

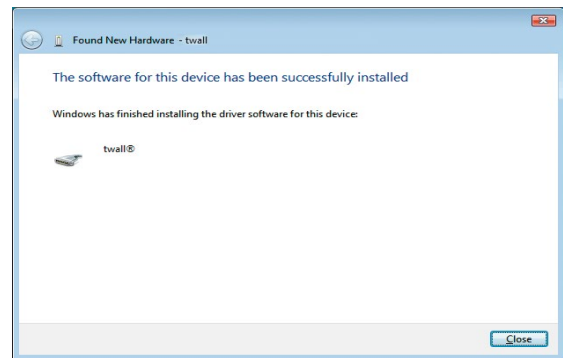

6 The installation of the driver for the twall® was completed successfully. The twall® can now be used.

7 If the twall® is connected to another USB slot, the driver is installed again. This happens automatically however. Administrator rights are required even so.

8.2.3 Driver installation under Microsoft 7®

1 Windows attempts to install the driver automatically. If unsuccessful, the following message is displayed. Continue to point 2.

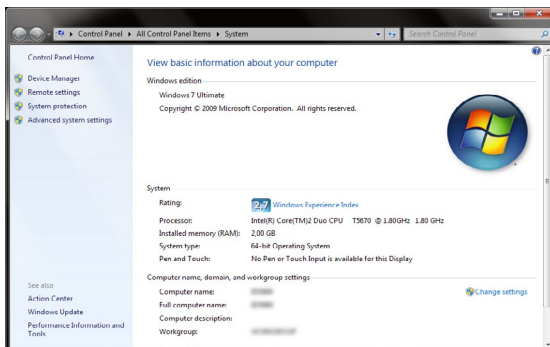
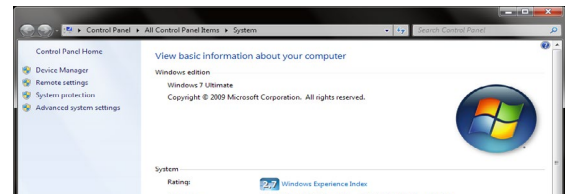

2 Start the device manager. To do this, open Start->System control ->System and security->System. A window with system information appears. Click on the left side of the page on "device manager".

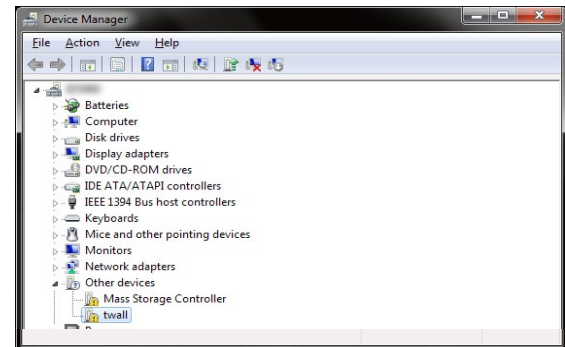

3 In the device manager, the twall® is shown under the category "Other devices" and highlighted with a yellow warning sign. Right click on "twall®" and select "Update driver".

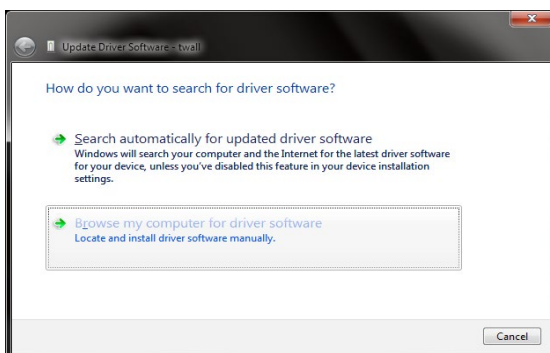

4 The driver installation assistant is now displayed. First of all, select "Search for driver software on the computer".

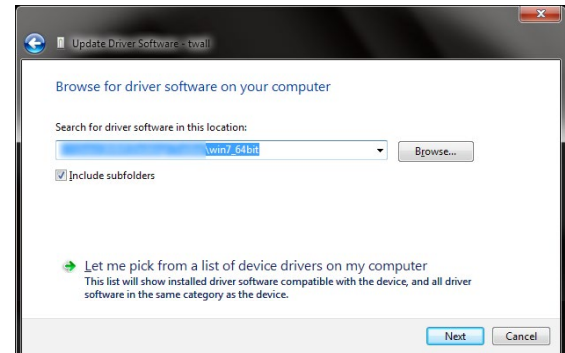

5 Secondly, enter the directory containing the driver for the twall®.

CAUTION: Windows 7 is available in 32-bit and 64-bit versions. Select the driver directory which is appropriate for your version of Windows. If you are unsure whether your version of Windows is 32-bit or 64-bit, you can check using the system information in the previously opened window.

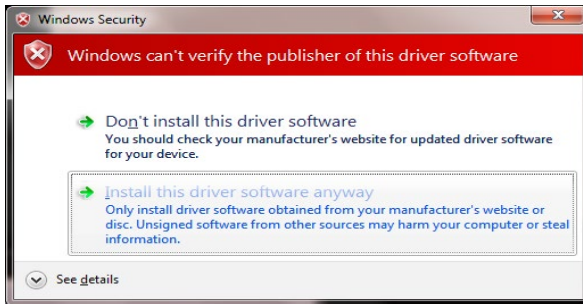

6 If the correct driver was indicated, this is now installed. Confirm the warning message shown with "Install this driver software anyway".

7 The driver installation is now complete.

8.3 Software installation

To install the twall® software, insert the twall® software CD into your computer's CD drive. Now start the file TwallSetup-1.0.exe and follow the on-screen instructions.

It is recommended that you select the installation type suitable for your twall®. With the installation type "Full installation", the programmes for all twall® variants are installed. However, bear in mind that a programme for twall® variant A is not necessarily compatible with twall® variant B.

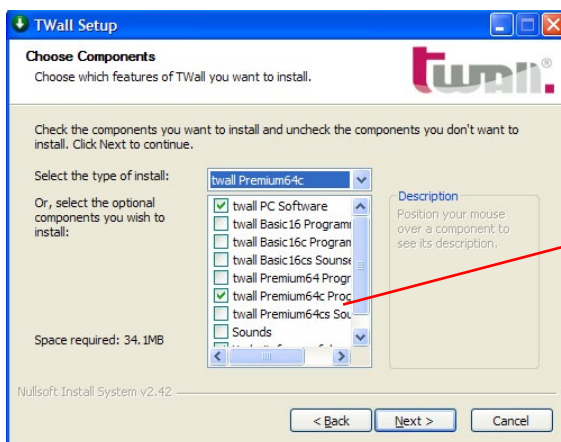

Select the installation type which corresponds to your twall® variant or full installation to be able to connect any twall® products

After installation, three shortcuts are located in the start menu or on the desktop, which each start the twall® software to a different extent in terms of function:

- ▶ TWall: full function (also editing settings).
- ▶ TWall (only executes programmes): Allows the execution of twall® programmes on the twall® and the simulation of twall® programmes on the computer.
- ▶ TWall (executes and edits programmes): As 2. with the added option of editing twall® programmes.

Limited software variants such as these can be used on computers installed in public areas.

8.4 Description of the software

8.4.1 The start page

After starting the software, the start page of the software is displayed. Click on the links to execute the corresponding action.

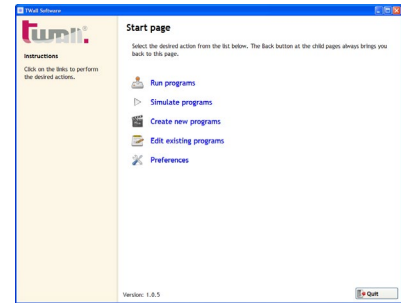

8.4.2 Programme settings

After the first programme start of the twall® software, the programme settings should be adjusted.

1 Select the program which is to be used as standard screensaver.

2 Using this button settings are transferred to the twall®. This requires entering of the password.

3 Remaining time in minutes before the screensaver starts. Setting it to zero, the screensaver will be disabled.

1 Stipulate here in which directories the twall® software is to search for programmes and/or sounds in order to complete the options displays for programmes and sounds.

2 Add a new directory to the list using this key.

3 The key deletes the selected entry from the list.

4 This is where information regarding the connected twall® is displayed. This information must always be quoted in the case of service.

8.4.2.1 Settings of the standard screensaver

Select the program from the program list, which is to be used as the standard screensaver. The time out for the screensaver is indicated in minutes. A zero value disables the screensaver. By using the button "set screensaver as standard" the settings will be transferred to the connected twall®. That requires the input of the password.

WARNING: The list of directories for twall® programmes contains after installation only the directories of the standard programmes in the software's installation folder. Your own programmes should not be stored in these directories as they would be deleted during deinstallation.

For this reason, add a directory to the list outside the twall® software installation folder (e.g. a new directory in "Own files") in which you can save self-created programmes. To save the settings, click on the [Save] key after you have made all the settings.

8.4.3 Executing the twall® programme

In this mode, you can:

- execute twall® programmes located on twall®.
- transfer to twall® and execute programmes located on twall®.
- save loaded twall® programmes.
- view high scores for twall® programmes.

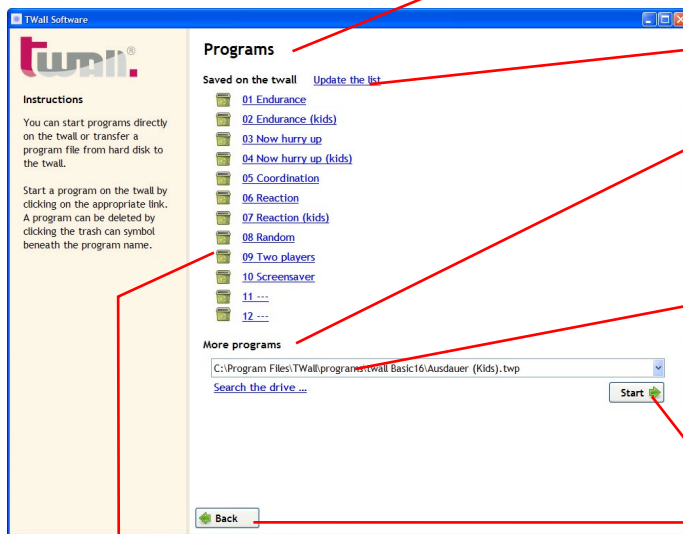

- 1 List of the programmes on tWall®. You can start a programme by clicking on the appropriate link.
- 2 This function refreshes the list of programmes on the tWall®.
- 3 This optionshows all the tWall® programmes which were found in the folders to be searched for tWall®.
- 4 Using this link, you can add to the list an individual file which is not in one of the searched folders.
- 5 Click on this key to send to the tWall® and start the programme s elected in the box.
- 6 The [Back] key takes you back to the start page.
- 7 With the waste basket symbol, the programme site in question is emptied (deletes the programme).

If a programme has been loaded, the software changes to status display. The status of the programme (time elapsed, score etc.) is displayed. This is where the loaded programme can also be saved on the tWall®.

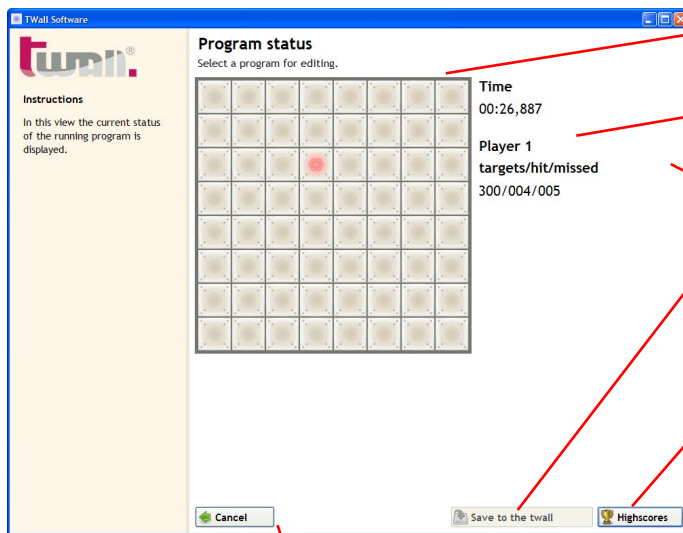

- 1 This fields indicates the current view of the tWall®.
- 2 Current playing time.
- 3 Status display for player 1.
- 4 With this key, the currently loaded programme is saved on the tWall® (only for programmes transferred from the hard disk).
- 5 Shows the high scores for the programme.
- 6 Aborts the execution of the loaded programme. Clicking again on this key returns the software to the "Programmes" page.

8.4.3.1 Saving programmess on the tWall®

Clicking on the ["Save on tWall®"] key displays a dialogue first of all in which the programme number must be indicated under which the programme is to be saved. The number corresponds to the programme number in the list of programmes available on the tWall® .

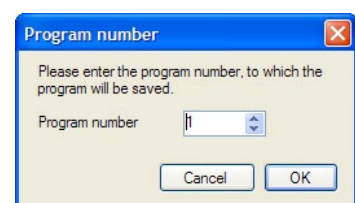

You have to enter a password to save a programme on the twall®. Enter this in the following dialogue box.

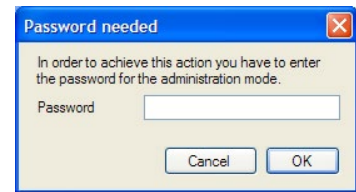

NOTE: The password is located on a label which is on the last page of the user manual. Only divulge this password to people who are also allowed to save programmes on the twall®.

8.4.3.2 High scores

Clicking on the [High scores] key in the status display loads the high scores for the programmes loaded. The most recent entry in the list is highlighted.

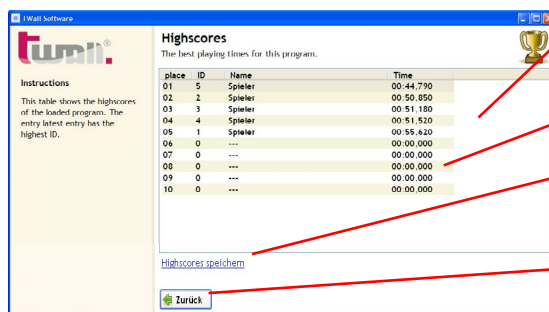

- 1 The last entry added is highlighted.
- 2 Empty entries.
- 3 With this function, the high score list is saved as a "high scores" file.
- 4 Back to status display.

If the programme had been started directly from the twall®, the high scores are also read out. If the programme was transferred from the computer to the twall®, the high scores are saved automatically in a "high scores" file. In this case, it is also possible to enter a name when achieving a place in the high score list. If the programme is subsequently saved on the twall®, this high scores file can also be transferred along with the previous high scores.

8.4.4 Simulating the twall® programmes

The programme function "Simulate programmes" offers you the option of executing twall® programmes on the computer without needing a twall® itself. This can be useful when newly created programmes are to be tested for example.

The software switches to status display depending on the selection of the programme to be simulated. The [Save on the twall®] and [High scores] functions are not possible with simulations.

In contrast to the status display for programmes which are executed on the twall®, the stylised twall® is an interactive element here. Instead of pressing the touch pads on the twall®, in the simulations you click with the mouse on the corresponding graphic key fields.

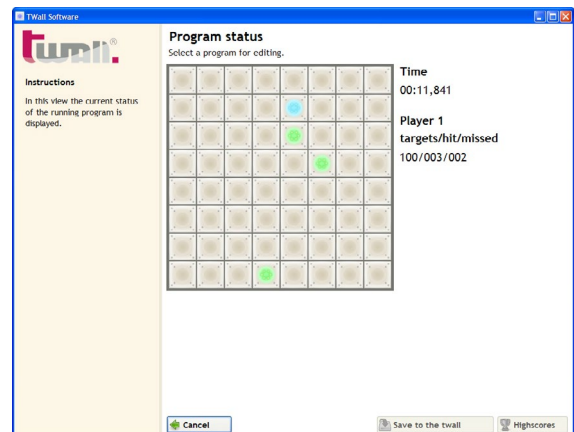

8.4.5 Creating new twall® programmes

Using the twall® programme editor software, new twall® programmes can be created. General parameters are set on the first page of the programme editor.

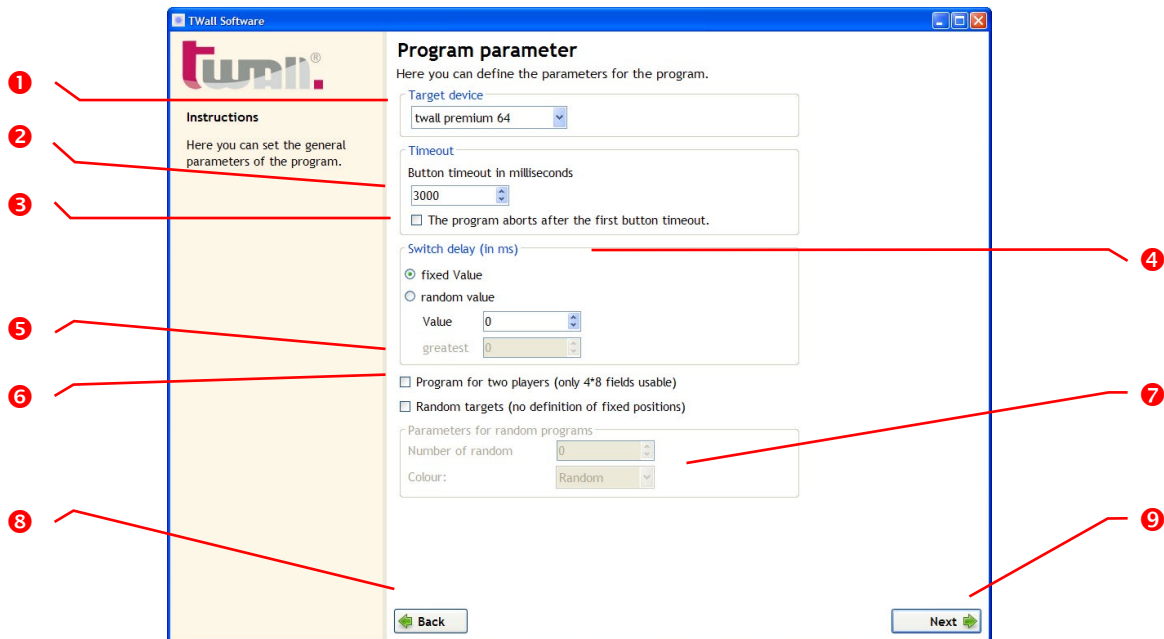

- 1 Under this option, the twall® type is set for which the programme is intended.
- 2 Enter a time-out here for the key fields. This is the maximum time which may elapse between activating (connecting) a key field and deactivating (pressing) a key field. The time-out is indicated in milliseconds between 1 and 65,000. Longer time-outs are not permitted for reasons connected with overheating. For this reason, avoid stipulating two identical targets with so high a time-out.
- 3 When a time-out is set and this field is activated, the programme aborts the execution as soon as a time-out has expired. The normal procedure in this case is that the current target is assessed as an error and the next key field is activated.
- 4 The input delay is the time between the deactivation of a key field and the activation of the next key field. The standard setting is zero (no delay). Selected "fixed value" and enter a number in the "Value" field in order to set a fixed delay of the time indicated. Select "random value" and enter two values in the "smallest" and "largest" fields in order to stipulate a random input delay for this area (the input delay is reselected for each new target).
- 5 Select this option to create a programme for two players. On the following page, you can only indicated targets on the left half of the twall®. The programme will then run identically for the two players.
- 6 If this option is selected, the following page on which the individual targets are selected does not apply. Instead, clicking on [Proceed] will save the programme. When executing the programme on the twall®, the positions of the targets are selected randomly.
- 7 Enter here the number of chance targets and their colour. A fixed colour can be selected or it can also be left to chance in exactly the same way as the targets.
- 8 Back to start page.
- 9 Proceed to the next page of the programme editor.

The individual targets can be stipulated on the second page of the programme editor. The programme editor operates in two different modes: Create and Edit. If no target is selected in the list of defined targets, clicking on the key field of the graphic **twall**® adds a new target to the list. The defined parameters/colours then refer to the next target to be added.

If an individual target is selected in the list, clicking on a key field of the graphic **twall**® changes the position of the target selected. The change to the parameters also corresponds to the target selected. If several targets in the list are selected, only the parameters of the targets selected can be changed.

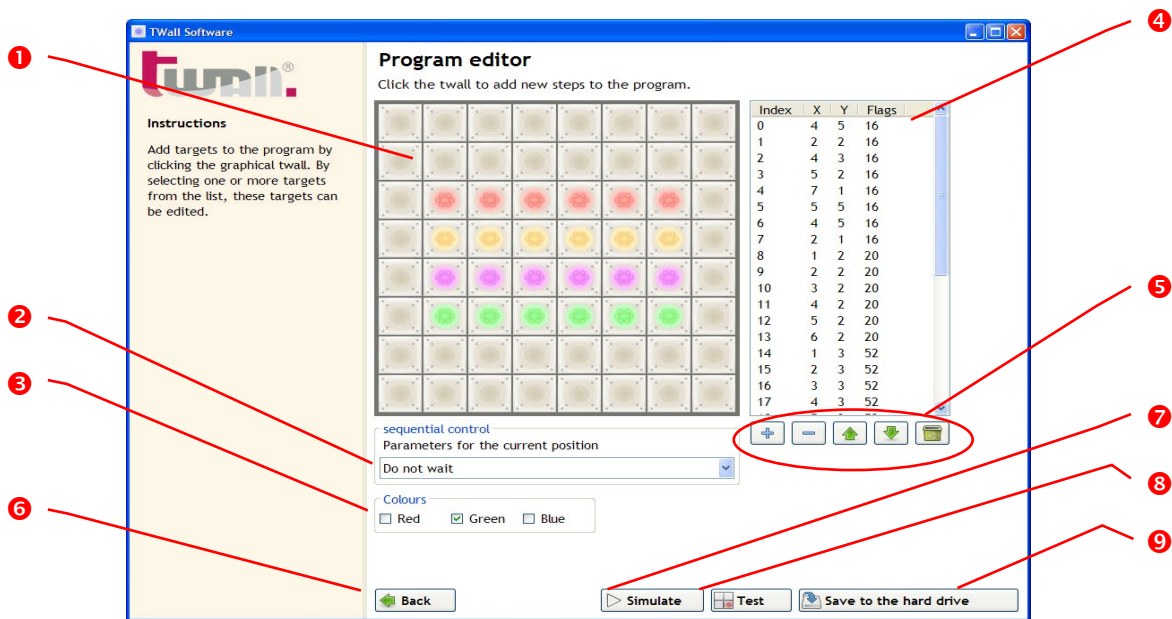





- ❶ Clicking on the graphic key fields adds new targets to the programme.
- ❷ This is where to set the sequential procedure for the selected/next target. The parameter stipulates which event will cause the sequence to move on to the next target.
- ❸ Using the three option fields you stipulate the colour for the selected/next target. The individual colour channels are created by combining colours (red + green + blue equals white).
- ❹ List of defined targets. The index indicates the number of the target in the programme sequence, X and Y stand for the horizontal or vertical position of the target. The flags contain the colour and parameter for the sequence.
- ❺ Use these keys to add targets to, delete targets from or rearrange the list, or to delete the entire list.
- ❻ Back to page 1 of the programme editor.
- ❼ Use this key to simulate the edited programme. To do this it must first be saved on the hard disk.
- ❽ Transfers the programme to the **twall**® and executes it directly. It is not possible to save it on the **twall**® in this mode.
- ❾ Saves the programme on the hard disk..

The following parameters are defined for the sequence:

- ▶ **wait until precisely this key was pressed:** this is the standard setting. The next target in the programme will only be activated when the current target is deactivated or the time-out has expired.
- ▶ **Wait until any active key was pressed:** the next target in the programme will only be activated when an active (illuminated) key is deactivated or the time-out has expired.
- ▶ **Wait until any key was pressed:** the next target in the programme will only be activated when any key - active or not - was pressed or the time-out has expired.
- ▶ **Wait until the last active key was pressed:** the next target in the programme will only be activated when the last active (illuminated) key has been deactivated or the time-out has expired. This mode is especially helpful when numerous key fields on the twall® light up and all need to be deactivated before the programme is ended or the programme sequence continues.
- ▶ **Don't wait:** the next target is activated immediately after the key field is switched on. This mode is required to connect numerous key fields simultaneously.

The following functions are available to edit the targets in the list:

-  Adds a new element to the list by duplicating the currently selected or the last element in the list.
-  Deletes the selected elements from the list.
-  These keys move the selected element one position down or up.
-  Deletes the entire list

8.4.6 Editing twall® programmes

To edit twall® programmes at a later date, click on [Edit existing programmes] on the start page. Then select the programme to be edited from the options display. In other respects, editing a programme is similar to creating new programmes.

8.4.7 Editing sound sets

Using sound sets, specific events of a twall® programme can be assigned sounds. Each twall® programme can be assigned a sound set².

In order to transfer the sounds to the twall®, the programme must first be transferred from the computer to the twall® and then saved (**see Chapter 8.4.3.1**). The sounds are then automatically transferred to the SD card on the twall® (the card must be inserted into the SD card slot).

1 Select here the twall® programme for which the sound set is to be processed.

2 This list contains all the events which can occur in the twall® programme. The sounds assigned can be seen in the "Sound" column.

3 This key can be used to test the sound selected.

4 This key saves the settings made.

5 If an event has been selected in the events list, this event can be assigned a sound using this options display.

8.5. Firmware update

ATTENTION

Starting with version 1.2.9 of twall® PC software the firmware update feature is no longer supported. If needed, please contact your dealer.

9 Service

Contact:

Monday to Thursday from 07.00 - 15.30

Friday from 07.00 - 14.30:

- tel. +49 3727 6205-80 fax +49 3727 6205-220
- e-mail service@imm-electronics.de

The following information is needed from you to initiate a service call:

- Customer number, telephone, e-mail address
- Information regarding the tWall®
 - Version: *Premium64*, *Basic16* or *Basic* fold-away or *Compact32*
 - tWall® serial number
 - Sound: J/N, language G/E/F, hardware revision, software version
- Information regarding the system (in the case of software problems):
 - Operating system, version of the PC software, messages in device manager

**In cases of emergency outside normal opening hours:
Emergency number (tWall® service mobile): +49 151 162 104 95**



www.imm-electronics.de | info@imm-electronics.de

Copyright © 08 / 2016 IMM electronics GmbH

The reproduction and distribution of this documentation and the exploitation of its contents belonging to the product and the software are permitted without the written permission of the IMM electronics GmbH.

All information in this document are carefully considered, because our products are constantly being developed, there may be variations! The current version can be found at:
[www.twall.de / download](http://www.twall.de/download).

manufacturer:	IMM electronics GmbH
	Leipziger Straße 32 09648 Mittweida
tel	+49 3727 6205-90
fax	+49 3727 6205-55
mail	info@imm-electronics.de
web	www.imm-electronics.de

Individual assembling steps - twall®Premium64 mobile

Assembling the frame base **A1**

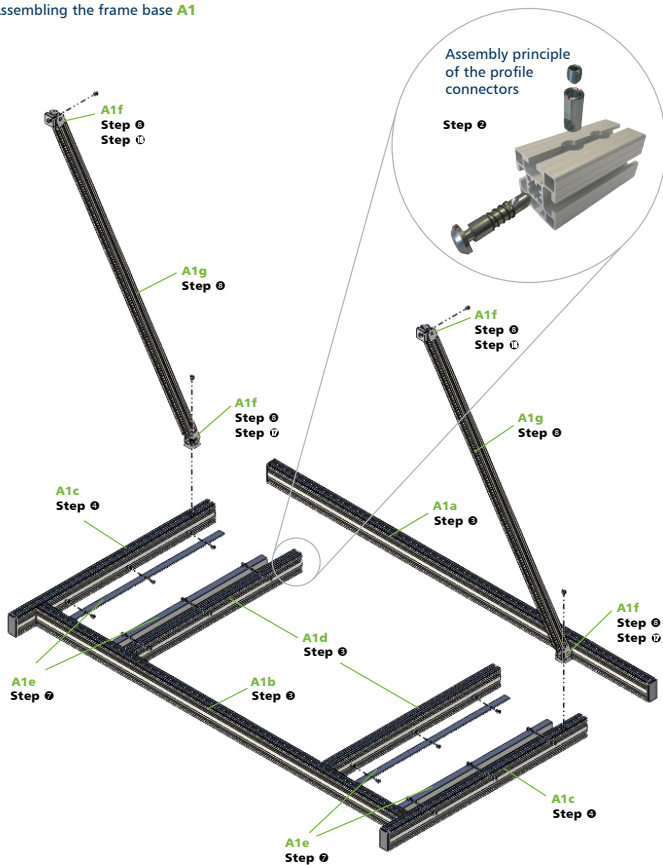

Montage Universalgestell **A2**

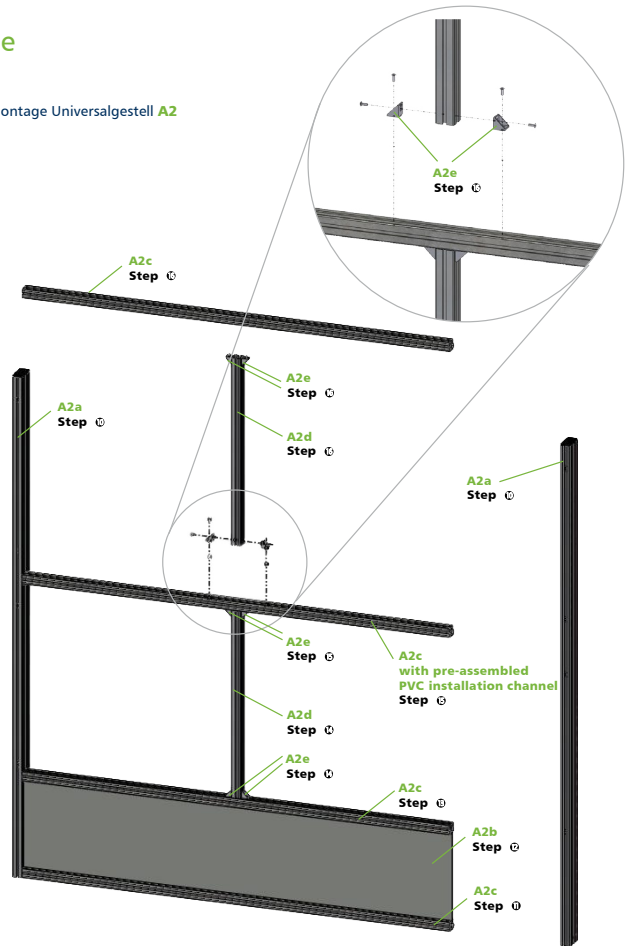

Individual assembling steps - twall®Premium64 stationary

We hope you will find that we have provided a useful manual to assemble and to operate the twall. However, please do not hesitate to contact us on info@twall.de with any suggestions you may have to improve this document. We appreciate your help.

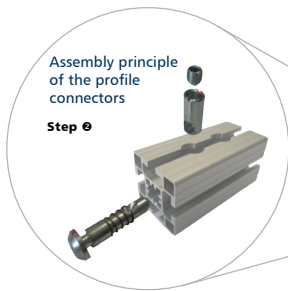

Montage Universalgestell **A2** me **A2**

