

# Sport-Thieme® „Duo Flex“ Punching Ball

**Thank you very much for choosing a Sport-Thieme product!**

Please read the instructions fully before you assemble the equipment, so you can enjoy the product and safety is guaranteed. We are happy to answer any questions you may have.



## Attention:

Do not operate with both spring fully locked or unit may be damaged. Each spring lock to be at the top or bottom position. Do not lock in middle or unit may be damaged. Do not operate otherwise or unit may be damaged. Do not unscrew and remove the lock knobs.

## Warning!

This Product is sold for use in high risk activities, before using this product, read all in closed information. Read entire manual before assembling or using this product. Retain this manual for future reference.

# OVERVIEW CHART & PARTS LIST

Please inventory all components to insure you have everything needed for assembly.

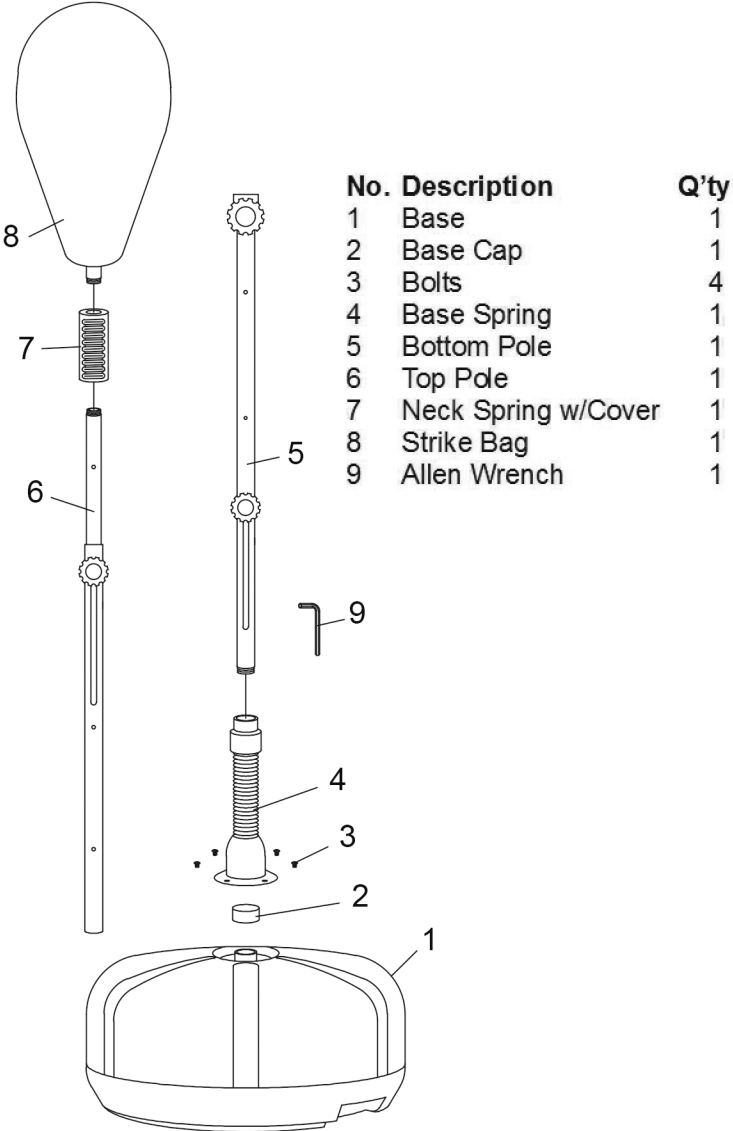

No.	Description	Q'ty
1	Base	1
2	Base Cap	1
3	Bolts	4
4	Base Spring	1
5	Bottom Pole	1
6	Top Pole	1
7	Neck Spring w/Cover	1
8	Strike Bag	1
9	Allen Wrench	1

# Assemble & instructions

**Step 1:** Remove cap (#2) and fill base (#1) with either sand or water. Replace cap (#2) and secure tightly.

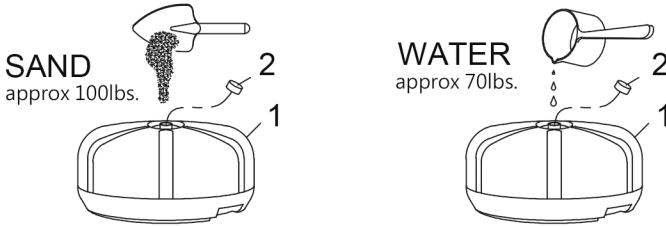

**Step 2:** Using the four Screws (#3) provided, attach the Base Spring (#4) to the base, tightening Screws by hand.

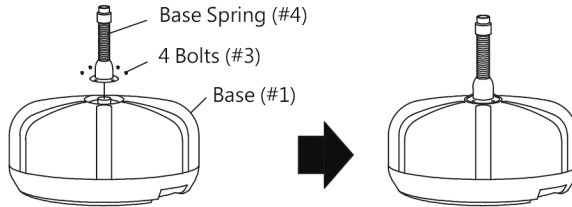

**Step 3:** Loosen the large knob on the Bottom Pole (#5). Insert Top Pole (#6) into Bottom Pole (#5). Tighten larger knob to secure.

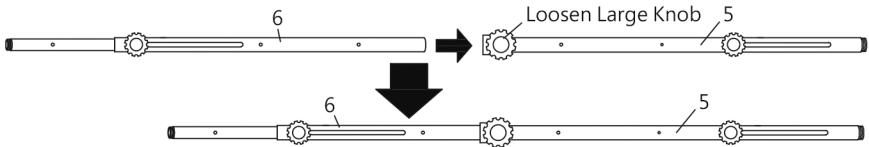

**Step 4:** Screw Neck Spring Bag (#8) into the top of the Neck Spring (with spring cover) (#7).

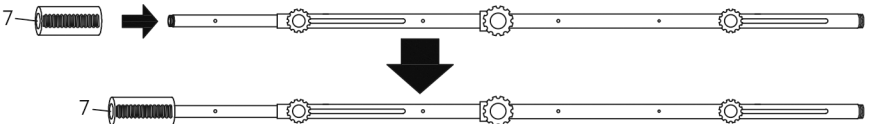

**Step 5:** Screw the Strike Bag (#8) into the top of the Neck Spring (with Spring Cover) (#7).

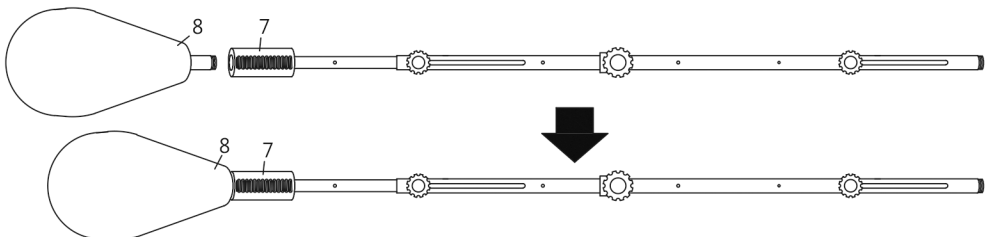

**Step 6:** Screw Bottom Pole (#5) into Base Spring (#4) Fully tighten four Screws (#3) with the Allen Wrench (#9) and double check all connections for stability.

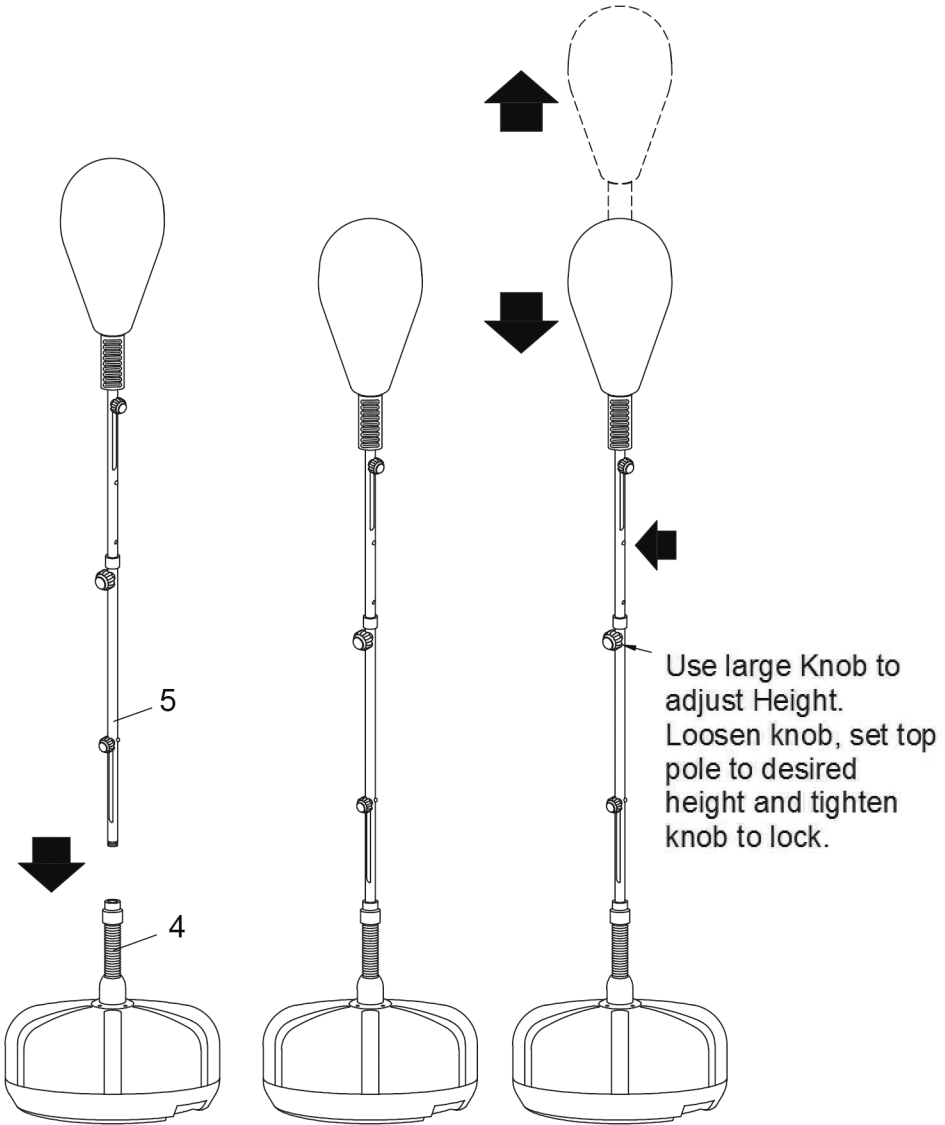



# 3 WORKOUTS IN 1

This Product uses a dual locking spring system. A Neck Spring right below the Strike bag, and a base. By locking or unlocking these you can achieve 3 unique Strike Bag Settings, Speed Flex and Hyper flex. Never use the Strike Bag with both springs in the lock position.

## Attention:

Do not operate with both spring fully locked o unit may be damaged. Each spring lock to be at the top or bottom position. Do not lock in middle or unit may be damaged. Do not operate otherwise or unit may be damaged. Do not unscrew and remove the lock knobs.

## 1. SPEED FLEX

### HOW? Lock Base, Unlock Neck

+ Setting is best for fast punches, combinations, and reflexes.

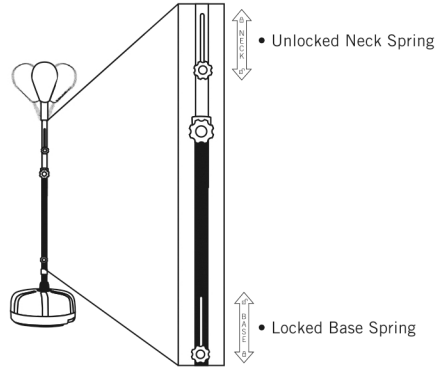

## 2. STRAIGHT FLEX

### HOW? Unlock Base, Lock Neck

+ Setting is best for punch techniques, agility, footwork, defense, and timing.

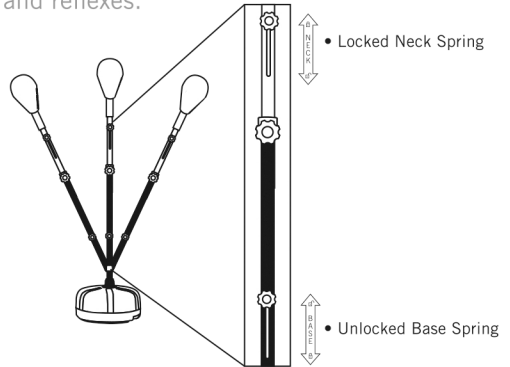

## 3. HYPERFLEX

### HOW? Unlock Base, Unlock Neck

+ Setting is for ultimate accuracy, speed, and agility training.  
+ Simulates sparring sessions for striking and defense.

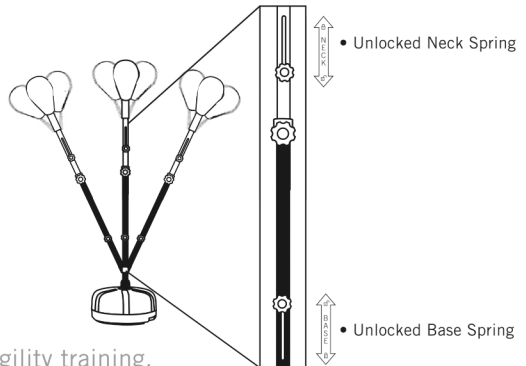

## Safety Guidelines and warning:

Before beginning any exercise program, you should consult with your doctor. It is recommended that you undergo a complete physical examination. The instruction must be read in full before assembly and / or use of this product.

**WARNING - YOU ARE RESPONSIBLE FOR YOUR OWN SAFETY.**

Work within your recommended exercise level, do NOT work to exhaustion. Injuries to health may result from incorrect or excessive training. If you feel any pain or abnormal symptoms, STOP YOUR WORKOUT IMMEDIATELY. Consult your physician immediately. After eating, allow 1 - 2 hours before exercising as this will help to prevent muscle strain.

Assemble and operate the equipment on a solid, level surface, ensure that the product is stable before use. The safety level of this equipment can only be maintained only if it is regularly always replace damaged / worn components with original parts from the manufacturer. The safety level of the equipment can be maintained only if it is regularly examined for damage and wear. This includes any ropes, pulleys, nuts, bolts, moving parts bushes, chains, wheels, bearing & points etc.

Replace defective components immediately, and / or keep the equipment out of use until it is repaired. It is important that you keep these instructions for further reference. Always check that any pins / fixings are tight and secure before use and / or after adjustment. Special attention to components most susceptible to wear. Special attention should be taken to inspect these components before use. If the adjustment devices are left projecting, they could interfere with the user's movement. To avoid from danger, wear proper workout gloves, hand wraps and etc. when using the equipment.



Correct punching postures

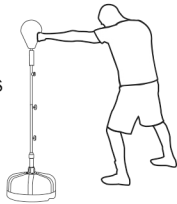

Incorrect punching posture

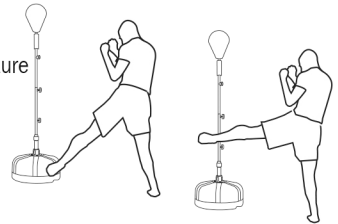

Push the base to move the product



No bending while moving



Keeping unsupervised children away from the equipment. If children are allowed to use the equipment, their mental and physical development and above all their temperament should be taken into account. They should be controlled and instructed in the correct use of the equipment. The equipment is under no circumstances suitable as a children's toy.

Never overload the equipment - the maximum user load is displayed on the product label. Do not wear shoes with sharp surface or high heels. And remove all personal jewelry before exercising. Don't rock the unit from side to side. Care should be taken when using and disusing this unit. Always allow a clear space measuring at least 1 m wide and 1 m long directly front/behind the equipment. Do not use any accessories that aren't specifically recommended by the manufacturer, these might cause injuries or cause the unit to fall.